

SELSER SCHAEFER ARCHITECTS

**Project Name:** Cherokee Nation Entertainment  
Cherokee Tower Renovation

**Item Number:** CS-FURN18

**Issue Date:** 10/2/13

**Item Description:** Wardrobe / Dresser Unit

**Revision(s):** Issue 02

**Area Name:** Chief's Suite Double Queen Bedroom

Item Pricing:		Total Quantity: 1	
<b>Manufacturer:</b>	Royal Custom Designs	<b>Source:</b>	Chip Norton Enterprises
<b>Address:</b>	1449 Industrial Park Street Covina, CA 91722	<b>Address:</b>	P.O. Box 140686 Dallas, TX 75214
<b>Phone</b>	626.967.5261	<b>Phone</b>	214.500.7519
<b>Fax</b>	626.967.5324	<b>Fax</b>	
<b>Contact</b>	See Source	<b>Contact</b>	Chip Norton
<b>Email</b>	www.royalcustomdesigns.com	<b>Email</b>	chip@nortonenterprisesna.com
<b>Web</b>		<b>Web</b>	www.nortonenterprisesna.com

**Description:** Combination wardrobe/dresser unit. Wardrobe has (2) full overlay doors with fixed shelf and hanging rod. Inset full length mirror on inside face of single wardrobe door. Dresser has (4) flush inset drawers with undermount self closing slides. Design based around Bernhardt Hospitality Bon Maison line.

**Material/Finish:** Maple Solids and Veneers with Toffee stain, semi-fill satin sheen, catalyzed varnish finish. Furniture finishing techniques to involve "distressing" to evoke a sense of age, "heirlooming" to emulate the natural process of wear and "hand-wiped glazes" that accentuate the uniqueness of the piece. Where indicated provide quartz top (Silestone Ivory Coast with bullnose edge)

**Dimensions:** 94"W x 26"D x 82"H Overall\*

**Drawer Pulls:** Rocky Mountain Hardware, Sash Pull CK311, 6" C-to-C, silicone bronze dark patina

**\*Note:** In order to fit in elevator cabs and through doorways, furniture piece will need to be fabricated into modular components that can be assembled onsite. Shop drawings shall indicate the modularity of the overall unit.

**Lead Time** 8-10 weeks after approval of shop drawings

**Required Item(s) for Designer Approval Prior to Fabrication:**

Seaming Diagram  Strike-Off  Finish Sample  Cutting  Shop Dwgs  Prototype  Flame Certificate  Other...

**Instructions:**

- Install per manufacturers recommendations.

SELSER SCHAEFER ARCHITECTS

**Project Name:** Cherokee Nation Entertainment  
Cherokee Tower Renovation

**Item Number:** CS-FURN18

**Issue Date:** 10/2/13

**Item Description:** Wardrobe / Dresser Unit

**Revision(s):** Issue 02

**Area Name:** Chief's Suite Double Queen Bedroom

**Item Pricing:**

**Total Quantity:** 1

**Manufacturer:** Royal Custom Designs

**Source:** Chip Norton Enterprises

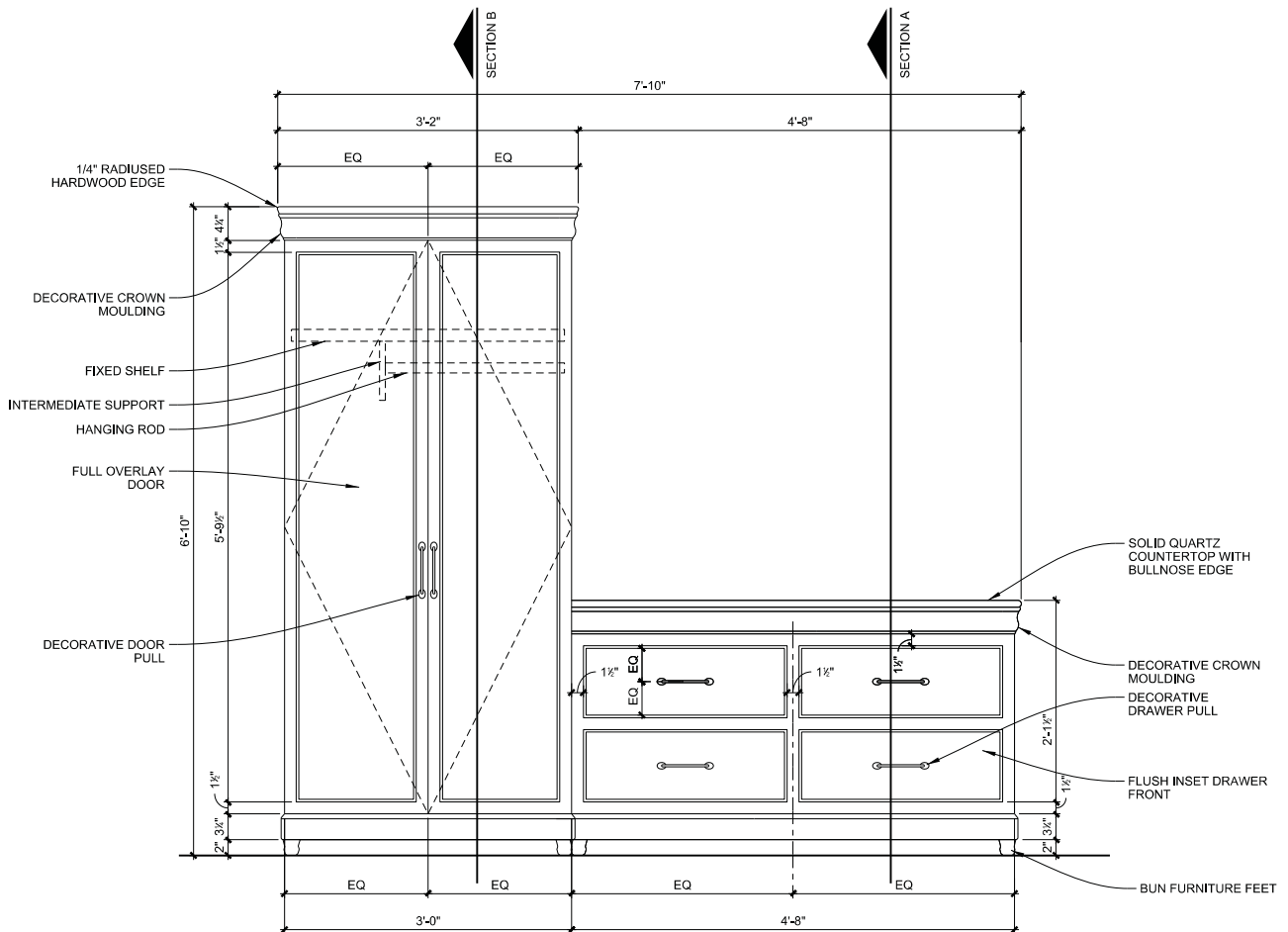

FRONT ELEVATION

SELSER SCHAEFER ARCHITECTS

**Project Name:** Cherokee Nation Entertainment  
Cherokee Tower Renovation

**Item Number:** CS-FURN18

**Issue Date:** 10/2/13

**Item Description:** Wardrobe / Dresser Unit

**Revision(s):** Issue 02

**Area Name:** Chief's Suite Double Queen Bedroom

**Item Pricing:**

**Total Quantity:** 1

**Manufacturer:** Royal Custom Designs

**Source:** Chip Norton Enterprises

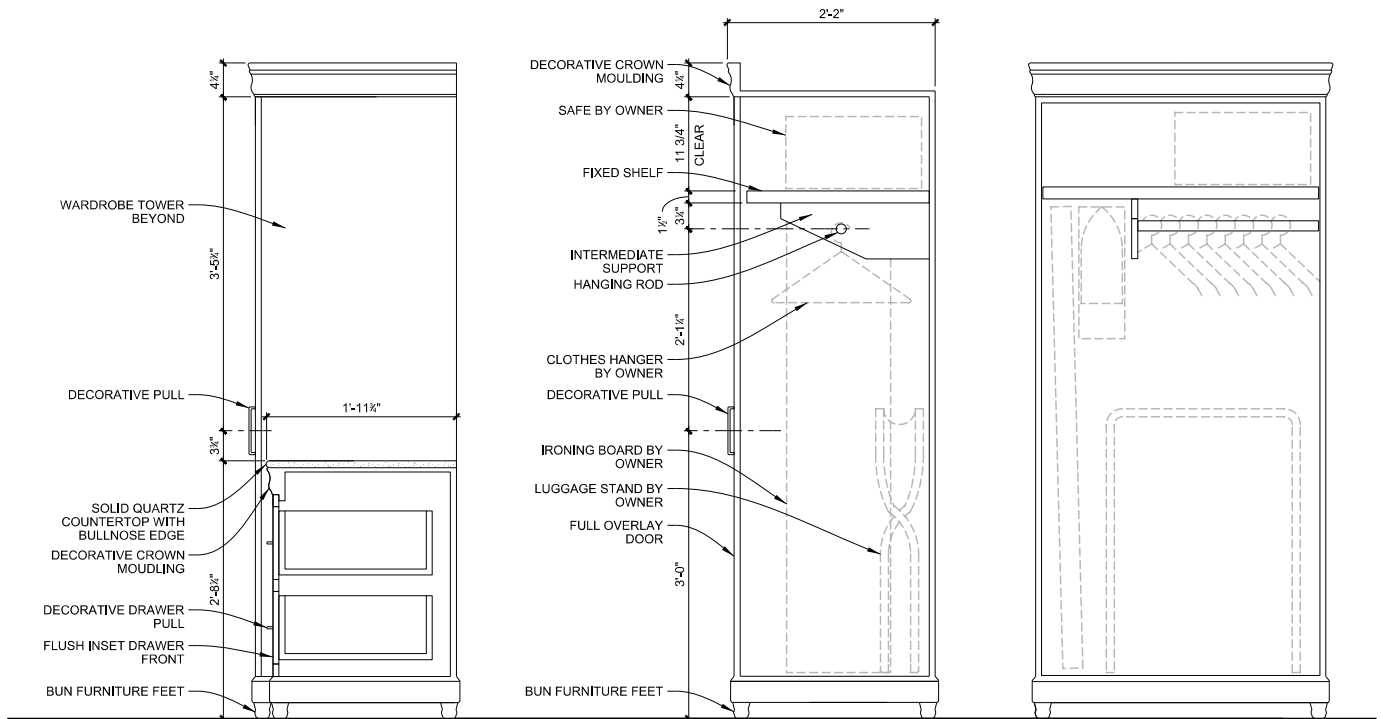

SECTION A

SECTION B

WARDROBE INTERIOR  
(DOORS NOT SHOWN FOR CLARITY)

SELSER SCHAEFER ARCHITECTS

**Project Name:** Cherokee Nation Entertainment  
Cherokee Tower Renovation

**Item Number:** CS-FURN18

**Issue Date:** 10/2/13

**Item Description:** Wardrobe / Dresser Unit

**Revision(s):** Issue 02

**Area Name:** Chief's Suite Double Queen Bedroom

---

**Item Pricing:**

**Total Quantity:** 1

**Manufacturer:** Royal Custom Designs

**Source:** Chip Norton Enterprises

---

