

FOREMAN | MANHATTAN
Construction Team



CHEROKEE NATION[™]
Entertainment

Tahlequah Casino
Tahlequah, OK

**CONSTRUCTION MANAGER'S
BID MANUAL**

TABLE OF CONTENTS

INTRODUCTORY INFORMATION

00 0110 TABLE OF CONTENTS

BIDDING REQUIRMENTS

00 21 13 INSTRUCTIONS TO BIDDERS

00 35 00 BID DOCUMENTS TO BE SUBMITTED WITH BID

00 35 00 REPRESENTATIONS AND CERITIFICATIONS

00 35 19 NON-COLLUSION AFFIDAVIT
00 35 21 BUSINESS RELATIONSHIP AFFIDAVIT
00 35 50 TERO – LEGISLATIVE ACT 01-14
00 35 55 TERO – GENERAL PROVISIONS
00 35 56 TERO – PROJECT LABOR AGREEMENT (Sample)
00 35 57 TERO – CORE CREW LIST (Sample)
00 35 58 TERO – PROJECT LABOR FEES (Sample)
00 35 59 TERO – Sign In Log (Sample)
00 35 80 CODE OF CONDUCT FOR CNE JOBSITES

00 45 00 PRE-QUALIFICATION REQUIREMENTS

00 45 13A PREQUALIFICATION INSTRUCTIONS
00 45 13B FORM 2 - PREQUALIFICATION FORM
00 45 13C FORM 4 - SAMPLE SURETY COMMITMENT LETTER
00 45 13E W-9 FORM
00 45 13F INSURANCE REQUIREMENTS

BID FORMS, BID PACKAGE LIST AND BID PACKAGES

00 50 00 BID PACKAGES

10.01 OPERABLE PARTITIONS
21.01 FIRE SUPPRESSION
23.01 PLUMBING AND HVAC
26.01 ELECTRICAL

00 60 00 SUBCONTRACT FORMS

00 60 01 SUBCONTRACT AGREEMENT
00 60 02A MANHATTAN GENERAL PROVISIONS
00 60 02B OKLAHOMA RIDER
00 60 03 EXHIBIT A – Scope of Work
00 60 04 EXHIBIT B – Subcontractor Performance and Payment Bonds
00 60 05 EXHIBIT C – Insurance
00 60 06 EXHIBIT D – Documents Listing
00 60 07 EXHIBIT E – Special Conditions
00 60 08 EXHIBIT F – Schedule
00 60 09 EXHIBIT G – Tax Exempt – O.D.P.I.
00 60 10 EXHIBIT H – Manhattan Additional Safety Requirements

00 61 00	PURCHASE ORDER FORMS
00 61 01	P.O. AGREEMENT
00 61 02	EXHIBIT A – PO Scope of Work
00 61 03	EXHIBIT B – Supplier Contract Bond
00 61 04	EXHIBIT C - Insurance
00 61 04A	EXHIBIT C - Insurance Sample
00 61 05	EXHIBIT D – Document Listing - - (See 00 60 06 Exhibit D)
00 61 07	EXHIBIT F – Schedule - - (See 00 60 08 Exhibit F)
00 61 08	EXHIBIT G – Tax Exempt – O.D.P.I.
00 61 09	EXHIBIT H – Manhattan Additional Safety Requirements
00 61 10	EXHIBIT I – Indemnification

00 70 00	CONTRACT MANAGER CONTRACT REQUIREMENTS
00 70 19	PROJECT SPECIFIC SAFETY PROGRAM
00 70 20	OPERATION ZERO STATEMENT
00 70 30	CM PAYMENT PROCEDURES
00 70 50	CM SHOP DRAWINGS, PRODUCT DATA AND SAMPLES

Instructions to Bidders

1. Receipt and Opening of Proposals:

Cherokee Nation Entertainment (“Owner”) on behalf of Foreman Manhattan Construction Team (herein called “Construction Manager”, “CM”, “Foreman Manhattan Team”, “FMC”, or “Foreman Manhattan”) acting as Construction Manager **is accepting SEALED bids on Friday May 25, 2018, at 2:00PM CST.**

All proposals should be sent by express delivery, regular mail or hand delivery to Cherokee Nation Businesses Catoosa Corporate office at the following address:

IF BY EXPRESS DELIVER OR REGULAR MAIL

Cherokee Nation Businesses, L.L.C.
Attn: Tina Jones, Buyer IV
777 W. Cherokee Street
Catoosa, Oklahoma 74015

IF BY HAND DELIVERY

Cherokee Nation Businesses, L.L.C.
Attn: Tina Jones, Buyer IV
Corp. Building #3
1102 N. 193rd East Ave.
Catoosa, OK 74015

Proposals shall be designated as: **CNE Tahlequah Casino – Scope Package # _____**

And properly marked with project name, name of bidder and bid package number. Any Proposal may be withdrawn prior to the scheduled time for the opening of bids or authorized postponement thereof.

Email delivery of Proposals shall NOT be accepted

2. Proposal Due Date:

Due Date: **Friday, May 25, 2018**

Time: **2:00 P.M. (CST)**

3. Content to be included at Foreman Manhattan Construction Team request:

Each bid proposal must be submitted on the prescribed form. All blank spaces for bid prices must be filled in, ink or typewritten. Bidder shall submit proposals using the prescribed forms included herein.

- a. Complete Scope Package Document
- b. Completed Affidavits
- c. Pre-qualification Documents (Section 00 45 00)
- d. TERO bidders must supply a copy of TERO Certificate, front and back.
- e. One (1ea) soft/digital copy of all the above (*.pdf format) on a USB Thumb Drive

4. **Bid Bond:**

Not Required

5. **Performance and Payment Bond Requirements: (Subcontractor contracts Only)**

Costs for performance and payment bonds **shall be included in your base bid and any applicable alternates or unit prices.** All exterior envelope Bid Packages (Trades) will be required to bond. In addition, all base bids, combination base Bid and including all alternates of \$100,000 or above will require Performance and Payment Bond equal to one hundred percent (100%) of the contract amount. Reference Section 00 60 04 – Exhibit B of the C.M. Bid Manual.

6. **Tribal Employment Rights Office.**

SUBCONTRACTOR IS TO COMPLY WITH ALL CHEROKEE NATION, TRIBAL EMPLOYMENT RIGHTS OFFICE (TERO), NATIONAL INDIAN GAMING ASSOCIATION (NIGA), AND ALL BUREAU OF INDIAN AFFAIR'S (BIA) RULES, REGULATIONS, AND LICENSING REQUIREMENTS INCLUDING ALL FEES AND ASSESSMENTS, ASSESSMENT, APPLICABLE TO THIS PROJECT.

11.1.1 - TERO document "An Act" Legislative Act 01-14 dated February 10, 2014.
This Document is ACT AMENDING LA 30-12, "CHEROKEE NATION EMPLOYMENT RIGHTS ACT"

11.1.2 - Subcontractors are to EXCLUDE the cost for Section; Title 40, § 1011; T.
To assess an Employee Rights Fee of one-half (1/2) of one percent (1%) on all covered contracts. This cost will be paid by the Construction Manager.

11.1.3 - The Work Permits paragraph of the Tribal Employment Rights Office (TERO) Project Labor Agreement - Master Agreement LA 01-14 states: No person who is not a member of a federally recognized tribe shall be employed by a covered employer until he or she has obtained a work permit from the TERO at a cost of twenty-five dollars (\$25) per day, per permit. Subcontractors are to INCLUDE in their proposed price for the work, all costs associated with the twenty-five (\$25) per day work permit for every non-Indian individual employed on this project.

7. **Pre-Qualification of Bidder:**

All bidders shall complete the Prequalification forms as attached. If previously submitted, check with **Jessica Allen at 918-583-6900 - J.Allen@manhattanconstruction.com** to satisfy whether previous submissions are up to date or have not been entered into the database. If out of date or if previously submitted and not entered as happens from time to time, please submit as a condition of Bid.

The Owner or Construction Manager reserves the right to reject any bid if the evidence submitted by, or investigation of, such bidder fails to satisfy the Owner or Construction Manager that such bidder is properly qualified to carry out the obligation of the Agreement for Construction and to complete the work contemplated therein

Further and as portion of the Foreman Manhattan qualification and if Foreman Manhattan so elects, Subcontractor agrees to furnish a Letter of credit (LOC) in lieu of providing a Performance and Payment Bonds.

8. **Sales Tax**

All bids must be submitted exclusive of Federal Excise Tax and Oklahoma State Sales Tax. The Cherokee Nation is exempt from Oklahoma State Sales Tax and Federal Excise Tax under authority of § Okla. Stat. Supp. 1994 Section 1356. Bidder is to include and

pay all other applicable sales tax and use taxes as required. Applications for payment shall be broken down as required by the Owner or Construction Manager.

Specific Project Requirements for the process, approval, and payment of Owner-Direct Payment Items (ODPI) are identified in section 00 60 09:

EXHIBIT "G"

Tax Exempt / Owner Direct Paid Invoice (ODPI) Payment Process

9. Schedule

Time is of the essence of the Contract. Bidders are to review the work of their particular Bid Package and all other Bid Packages in relation to the Project Schedule. The Subcontractor is committing to the Master Schedule of the project by submitting a Bid.

Subcontractor should include all remobilization charges required per the Project schedule.

10. Examination of bid documents:

Bid Documents can be obtained electronically from the Cherokee Nation Commerce website:

<http://www.cherokeebids.org>

Hard copy of Bid Documents can be viewed at:

Small Business Assistance Center
Tahlequah Oklahoma 74464
(918) 453-5536
sbac@cheokee.org

11. Examination of Site

Contractor shall examine site, make notes of existing conditions, comparing such with the plans and specifications, and be fully satisfied as to conditions of such before submitting his proposal. No allowance shall be subsequently made to the Contractor by reason of any error on his part.

Pre-bid date is scheduled for:

Location: Proposed Project Site
3307 South Seven Clans Avenue
Tahlequah, OK 74464

Date: Thursday, May 17, 2018
Time: 11:00 AM CST

12. All Questions and Interpretations of the Bid documents:

Project Contact: Tina Jones, Buyer IV

(918) 384-7802
Tina.Jones@cnet.com

Deadline cut-off date for all questions concerning this specific Bid is 12:00 (Noon) on Tuesday, May 22, 2018.

13. Acceptance and/or Rejection of Bid Proposals:

Foreman Manhattan will privately open bids with the Client. The Owner and/or the Construction Manager expressly reserve the right to waive all formalities or minor irregularities and to reject any or all bids. Combination of bid packages, incomplete bid packages and/or qualified bids may be subject to rejection.

No bid shall be withdrawn for sixty (60) calendar days after bidding.

14. Bid Alternates:

Bid Alternate price shall be held for (90) calendar days after bidding.

15. Bid Opening:

Bids will be opened in private by Owner and Foreman Manhattan Construction Team.

The bidder must plan for a post bid meeting/interview to review bidder's proposal and scope of work associated with the project. This post bid de-scope meeting/interview will be scheduled at the close of business day a minimum of 48-hours after the initial Bid Day.

A second additional 48-hour period shall be extended in order to follow TERO requirements and procedures.

It is the intention of CNB to award this project within 30 days of the proposal date.

Any proposal received more than ninety-six (96) hours, excluding Saturdays, Sundays and holidays, before the time set for the opening of proposals, or any proposal so received after the time set for opening of proposals, shall not be considered and shall be returned unopened to the proposing firm submitting same.

Cherokee Nation Businesses and Foreman Manhattan Construction Team will privately review bids. The Owner and/or the Construction Manager expressly reserve the right to waive all formalities or minor irregularities and to reject any or all bids. Combination of bid packages, incomplete bid packages and/or qualified bids may be subject to rejection.

NOTE: A location Map has been attached to this document.

The bidder must supply all the information required by the RFP Documents, hereinafter defined.

End of Instructions to Bidders

BID AFFIDAVITS

NON-COLLUSION AFFIDAVIT

The following affidavit is to accompany the bid:

STATE OF _____)
) ss.
COUNTY OF _____)

1. (s)he is the fully authorized agent of _____, the bidder submitting the competitive bid which is attached to this statement, for the purpose of certifying the facts pertaining to the existence of collusion among bidders and between bidders and state officials or employees, as well as facts pertaining to the giving or offering of things of value to government personnel in return for special consideration in the letting of any contract pursuant to the bid to which this statement is attached;
2. (s)he is fully aware of the fact and circumstances surrounding the making of the bid to which this statement is attached and has been personally and directly involved in the proceedings leading to the submission of such bid; and
3. neither the bidder nor anyone subject to the bidder's direction or control has been party:
 - a. to any collusion among bidders in restraint of freedom of competition by agreement to bid at a fixed price or to refrain from bidding,
 - b. to any collusion with any state official or employee as to quantity, quality or price in the prospective contract, or as to any other terms of such prospective contract, nor
 - c. in any discussions between bidders and any state official concerning exchange of money or other thing of value for special consideration in the letting of a contract.

Name of Bidder
by _____

Title

Subscribed and sworn to before me this _____ day of _____, 20_____.

Notary Public (or Court Clerk or Judge)

My Commission Expires:

Commission No.: _____

BUSINESS RELATIONSHIPS AFFIDAVIT

STATE OF _____)
) ss.
COUNTY OF _____)

I, _____, of lawful age, being first duly sworn, on oath says, that (s)he is the agent authorized by the bidder to submit the attached bid. Affiant further states that the nature of any partnership, joint venture, or other business relationship presently in effect or which existed within one (1) year prior to the date of this statement with the Architect, Engineer, or other party to the project is as follows:

Affiant further states that any such business relationship presently in effect or which existed within one (1) year prior to the date of this statement between any officer or director of the bidding company and any officer or director of the architectural or engineering firm or other party to the project is as follows:

Affiant further states that the names of all persons having any such business relationships and the positions they hold with their respective companies or firms are as follows:

(If none of the business relationships hereinabove mentioned exist, affiant should so state.)

_____ Name of Bidder
by _____
_____ Title

Subscribed and sworn to before me this ____ day of _____, 20 ____.

_____ Notary Public (or Court Clerk or Judge)

My Commission Expires:

Commission No.: _____

An Act

Legislative Act 01-14

ACT AMENDING LA 30-12, "CHEROKEE NATION EMPLOYMENT RIGHTS ACT"

BE IT ENACTED BY THE CHEROKEE NATION:

Section 1. Title 40, § 1001 shall read as follows: Title and Codification

This Act shall be referred to as an Act Repealing and Superseding the Cherokee Nation Employment Rights Ordinance, Cherokee Nation Code Annotated, Title 40, Chapters One through Six, Sections 1 through 65. This Act shall be codified at Title 40, Sections 1001 et seq. and shall be known as the Cherokee Nation Employment Rights Act.

Section 2. Title 40, § 1002 shall read as follows: Legislative History

The Cherokee Nation previously enacted the Cherokee Nation Employment Rights Ordinance, effective January 11, 1986, by Legislative Act 22-87, and as amended by Legislative Act 29-88. This Act repeals said legislation and supersedes said legislation as codified at Cherokee Nation Code Annotated, Title 40, Chapters One through Six, Sections 1 through 65.

The purpose of this Act is to repeal the current Cherokee Nation Employment Rights Ordinance, codified at Cherokee Nation Code Annotated, Title 40, Chapters One through Six, Sections 1 through 65, and to supersede said law to: clarify the responsibilities of those entities involved in employment rights; to conform the Act to federal and tribal policies; and to clarify requirements regarding Indian preference.

Section 3. Title 40, § 1003 shall read as follows: Purpose

The purpose of this Title is to encourage employment of Indians and to assist in and require the fair employment of Indians and to prevent discrimination against Indians in the employment practices of employers who are doing business with the Cherokee Nation on Cherokee Nation Indian Country or in such jurisdiction as is provided in a cooperative agreement between the Cherokee Nation and another government.

Section 4. Title 40, § 1004 shall read as follows: Definitions

- A. "Administration" shall mean the Executive Branch of the Cherokee Nation as provided in the Cherokee Nation Constitution.
- B. "Cherokee Nation Indian Country" shall mean ~~all land held in trust or subject to restrictions by the United States for the Cherokee Nation, or land within the original boundaries of the Cherokee Nation and held in trust or subject to restrictions for an individual, and all land held by the Cherokee Nation or its entities, in fee simple, and any other land within the jurisdiction of the Cherokee Nation which land comes within the definition of "Indian Country" as defined in 18 U.S.C. § 1151.~~ the territorial boundaries

of the Cherokee Nation as defined within the Cherokee Nation 1999 Constitution, Article II.

- C. "Cherokee Nation Government" shall mean the officials and employees **of the** ~~at the Cherokee Nation complex located at Tahlequah Oklahoma~~ and its programs or commissions wherever located. "Cherokee Nation" shall mean the government of Cherokee citizens, authorized by the Act of Union of 1839.
- D. "Contractor" shall mean any person, company or other entity engaged in work with the Cherokee Nation, its entities or wholly-owned corporations. The term "contractor" includes Cherokee Nation, its entities and wholly-owned corporations, ~~federal, state and county government agencies~~ and includes contractors, and subcontractors **thereof.** ~~of all other agencies.~~ **This term shall not include federal, state, or county government agencies to the extent prohibited by federal or state law.**
- E. "Core crew" shall mean an owner of the firm, or an employee **of a company** who is in a supervisory or other key position such that the employer would face a serious financial damage or loss if that position were filled by a person who had not previously worked for the **employer,** contractor or subcontractor.
- F. "Council" shall mean the Tribal Council of the Cherokee Nation as established pursuant to the Cherokee Nation Constitution.
- G. "Debarment List" shall be a list of contractors which have previously provided poor performance or engaged in behavior in non-compliance with contract provisions, rules, regulations, or laws.
- H. "EEOC" shall mean the Equal Employment Opportunity Commission of the United States.
- I. "Emergency" means any condition that places an extreme **physical or** emotional **condition** or financial burden on a Cherokee Citizen. (After all reasonable efforts have been made to contact a TERO Vendor)
- K.J.** "Employer" shall mean **(i) Cherokee Nation, its entities and wholly-owned corporations, (ii) any person, company, contractor, subcontractor or other entity located in or on Cherokee Nation Indian Country or engaged in work on a Project with the Cherokee Nation, its entities or wholly-owned corporations employing two or more persons, or (iii) any person or entity employing two or more persons located within Cherokee Nation Indian Country that has applied for or received certification with the TERO Office.** ~~For the Purpose of this Act, the term "employer" includes Cherokee Nation, its entities and wholly-owned corporations, federal, state and county government agencies and includes contractors, and subcontractors of all other agencies.~~ **The term "Employer" shall not include companies that are engaged in government contracting or other activities where the application of this law may violate applicable federal or state laws.**

- K. An employer is "engaged in work" if, during any portion of a business enterprise or specific project, contract or subcontract, the employer performs work under contract with the Cherokee Nation, its entities and wholly-owned corporations and/or the work is performed on Cherokee Nation Indian Country.
- L. ~~"HRC" shall mean the Human Rights Commission of the State of Oklahoma.~~ **Reserved for Future Use**
- M. "Indian" shall mean a person who is a member of a federally recognized Indian tribe ~~and/or any person recognized as an Indian by the United States pursuant to its trust responsibility to American Indians.~~
- N. "Indian organization" shall mean the governing body of any Indian Tribe or entity established or recognized by such governing body in accordance with the Indian Financing Act of 1974 (88 Stat. 77, 25 U.S.C. § 1451).
- O. "Indian-owned economic enterprise" shall mean any Indian-owned commercial, industrial, or business activity established or organized for the purpose of profit, provided that such Indian ownership shall constitute not less than 51 percent (51%) of the enterprise, and the ownership shall encompass active operation and control of the enterprise.
- P. "Indian Tribe" means an Indian Tribe, pueblo, band, nation, or other organized group or community, including any Alaska Native Village or regional or village corporation as defined in or established pursuant to the Alaska Native Claims Settlement Act (85 Stat. 688,43 U.S.C. § 1601), which is recognized as eligible for the special programs and services provided by the United States to Indians because of their status as Indians.
- Q. "Locally Owned" means a business that has its headquarters and majority of its employees residing within the jurisdictional boundaries of the Cherokee Nation, as described in Article II of the Cherokee Constitution, or counties contiguous to those boundaries
- R. An employer is "located ~~in or on the~~ **within** Cherokee Nation **Indian Country**" if, during **and in connection with** any portion of a business enterprise or specific project, contract or subcontract, the employer maintains a temporary or permanent office or facility on or performs work on Cherokee Nation Indian Country.
- S. "Major Cherokee Employer" shall mean an Indian owned business that employs at least 50 Cherokee Citizens as either part of the core crew or project crew, or has at least 75% of its workforce comprised of Cherokee Citizens as certified by the TERO. A business may be certified as Indian Owned, major Cherokee Employer, or both.
- T. "Nation" shall mean the Cherokee Nation.
- U. "OFCCCP" shall mean the Office of Federal Contract Compliance Programs of the United States.

- V. "One Stop Business Center" means a centralized location where Cherokee Owned businesses can obtain information regarding procurements, training, and financing.
- W. "Secretary" shall mean the United States Secretary of the Interior or his or her duly authorized representatives.
- X. "Tribal ~~member~~ **Citizen**" or "~~member~~" shall mean any person who is a duly enrolled citizen **member** of the Cherokee nNation, ~~unless the context clearly indicates otherwise.~~
- Y. "TERO" shall mean the Tribal Employment Rights Office.
- Z. "TERO Staff" shall mean employees assigned to the TERO Office by the Executive Branch of the Cherokee Nation.

AA. "Project" shall mean any construction, alteration, or repair of buildings or structures performed for Cherokee Nation or its entities.

Section 5. Title 40, § 1011 shall read as follows:

Tribal Employment Rights Office; Establishment, authority and duties

There is hereby recognized the Tribal Employment Rights Office (hereinafter referred to as the "TERO"). The TERO shall administer the employment rights program of the Cherokee Nation in accordance with this Title.

The TERO shall have the authority:

- A. To operate consistent with the provisions of this Title and to develop rules and regulations governing activities of TERO. The TERO may adopt EEOC guidelines or may adopt other requirements to eliminate employment barriers unique to Indians in Indian Country.
- B. To obtain funding from Federal, state and other sources to supplement Council appropriations as delegated by the Administration.
- C. To negotiate cooperative agreements with federal, state, local, and other authorities on matters dealing with employment rights and TERO activities and to operate pursuant to finalized cooperative agreements and/or memoranda of understanding or agreement.
- D. To use the information, facilities, personnel, and other resources of federal, state, and local agencies, **as allowed by those agencies**, as well as any and all Cherokee Nation departments.
- ~~E. To establish numerical hiring goals and timetables specifying the minimum number of Indians an employer must hire by craft or skill level.~~
- FE.** To require employers to establish or participate in job training programs as the TERO deems necessary to increase the pool of Indians eligible for employment.
- GF.** To establish and administer a tribal job bank and require employers to use it.

- HG.** To prohibit employers from using job-qualification criteria or personnel requirements that may bar Indians from employment unless such criteria or requirements are required by business necessity.
- HH.** To engage in the process of certifying businesses as "Indian-owned economic enterprises" and to determine whether businesses may be given Indian preference.
- HJ.** To direct inspections of regulated sites and determine compliance with rules, regulations, and/or contract requirements. **A "regulated site" shall be any site where an Employer is engaged in work as defined by this Act.**
- KJ.** To negotiate agreements with unions to insure union compliance with this Title.
- LK.** To require employers/contractors to follow the preferences as required in §1021 ~~give preference to Indian-owned economic enterprises in the award of contracts and subcontracts.~~
- MKML.** To establish counseling programs to assist Indians in obtaining and retaining employment.
- NLNM.** To require employers to submit reports and take all actions deemed necessary by the TERO for the fair and vigorous implementation of this Act.
- OMON.** To enter into cooperative agreements with employment rights agencies such as EEOC, HRC, and OFCCP to eliminate adverse discrimination against Indians.
- PNPO.** To take such actions as are necessary to achieve the purposes and objectives of the Cherokee Nation employment rights program established in this Title.
- QOP.** ——— To publish a listing of certified "Indian-owned economic enterprises."
- RPQ.** To review and propose changes to this Title and related regulations as necessary.
- SQR.** To hold hearings **participate and cooperate in appeal hearings** in accordance with this chapter.
- TRS.** To register and keep file of **records and** complaints concerning certified, Indian-owned economic enterprises and with individuals and companies doing business with the Cherokee Nation.
- UST.** To assess an employment rights fee of one-half (1/2) of one percent (1%) on all covered contracts, **which shall mean any contract executed by a contractor as defined in Title 40§1004.**
- VT.U.** To issue and assess fees for Work Permits which must be obtained for all non-Indian employees of a covered **an** employer, **who are not considered a core crew member.**

1. Any employer, as defined in this act shall be required to pay a fee of not less than Twenty-five dollars per employee per day for non-Indian employees hired for the **a Pproject or hired after the effective date of Legislative Act 30-12 if the Employer is the Cherokee Nation or its entities.**

2. Each such employer shall be required to submit a core crew list to the TERO.
3. Once the core crew list is submitted the TERO will confirm the ~~essential employees~~ **core crew members** the vendor has listed **and those employees shall be not be exempt from the requirement to obtain a Work Permit and but no fee will be due for the core crew employees.**
4. If the TERO has identified Indians that can be used for non-Indian Employees it shall ~~require the employer to place the qualified Indians~~ **submit the name to the Employer for consideration of replacement of the non-Indian Employees. Failure to hire the qualified Indians submitted by TERO will result in termination of the Employer's contract with the Cherokee Nation or its entities.**
5. The TERO is also authorized to administer other fees and penalties as provided in this act.
6. **An Employer is exempt from the assessment of a fee or penalties as provided in this Act if the Employer can prove to the TERO that the Employer followed the preferences under this Act through posting of a job announcement twice, Employer submits job descriptions to TERO for qualified Indians, and through proof that no Indian applicant was qualified or no Indian applied.**

Section 6. Title 40, § 1012 shall read as follows:

Adoption of rules, regulations, policies and guidelines

The TERO and its staff shall, with all reasonable speed, adopt detailed rules, regulations, policies and guidelines to fully implement this Title and the purposes and responsibilities of the TERO.

Section 7. Title 40, § 1013 shall read as follows:

Funds

All funds from employer fees and other sources collected by the TERO shall be tribal funds and be allocated to job training programs developed by the TERO staff and approved by the Council.

Section 8. Title 40, § 1021 shall read as follows:

Indian preference requirements generally

- A. All employers are required to give preference to ~~Indians~~ **Cherokee Nation Citizens first, then Cherokees from the two other federally recognized Cherokee Tribes, and then members of other federally recognized tribes** in hiring, promotion, training, and all other aspects of employment, contracting, or sub-contracting, **unless such preference would subject the employer to a violation of a federal or state law applicable to that employer,** and must comply with this Title and the rules, regulations and orders of the TERO.

1. The Cherokee Nation government is an “employer” for the purposes of this title and any of its business entities, **subject to the exceptions listed in Title 40 § 1004 (KJ)**, shall be an “employer” for the purpose of this title.
2. If potential contractors are otherwise equally qualified to complete the relevant contract work and respective bids are otherwise equal, the Cherokee Nation, its entities and wholly owned corporations shall apply a preference **Indian-owned as set forth in Sections d (i) (ii) (iii) (iv) hereinbelow** for economic enterprises in procurement and contracting. Exceptions to this requirement shall be permitted when no Indian-owned economic enterprise is readily available **as designated by TERO; when applicable federal or state law does not permit such a preference;** when other governmental entity contracts (including, but not limited to, VA or GSA contracts) are available; when more favorable pricing may be obtained; when the order meets the requirements of the Sole Source Request as defined in Acquisition policy and procedure; **when the contract price is below \$5,000.00** or in an emergency situation as determined by the Principal Chief.
 - a. primary preference shall be given to certified “Indian Owned Businesses” where the Majority Owner(s) are Cherokee citizen:
 - b. second preference to other certified “Indian Owned businesses” and,
 - c. A business may be certified as both an “Indian Owned” and “Major Cherokee Employer” business. In this case, such dually certified business would receive preference over other Indian-owned businesses within categories a. and b. above.
 - d. Preference shall be given in the following order:
 - i. First Preference shall be given to Cherokee owned business that are Major Cherokee Employers
 - ii. Second Preference shall go to Cherokee Owned Businesses
 - iii. Third Preference shall go to businesses that are certified as Indian Owned and that are Major Cherokee Employers
 - iv. Final Preference shall go to those businesses that are certified as Indian Owned.
3. Following the preferences in item 2. above, the procurement offices of the Nation shall develop policies to administer to “Locally-Owned businesses” as defined herein. In no instance shall this preference degradate or superseded Indian Preference.
4. Any contract awarded to a general contractor may be subcontracted, provided that the Indian Preference requirements herein apply **unless applicable federal or state law prevents the Indian Preference application**, regardless of the level of subcontracting activity. Failure to apply Indian preference to subcontracts shall be deemed by TERO a violation of this act, **unless applicable federal or state law prevents the application of an Indian Preference. The contractor/employer have the burden of proving to TERO that federal or state law applies to that contractor/employer and prevents the Indian Preference application.**

5. The Cherokee Nation Administration may create procurement and contracting policies and procedures for application of said preference. The Cherokee Nation procurement and/or contracting offices ~~may~~ **shall** maintain a list of entities which have previously provided poor performance or engaged in behavior in non-compliance with contract provisions, rules, regulations, or laws **and shall also maintain a list of entities which have provided good performance and satisfactory work and have engaged in compliant behavior with contract provisions, rules, regulations or laws.**
 6. Nothing shall require the Cherokee Nation to contract with or hire any Indian-owned economic enterprises which have previously provided poor performance or engaged in behavior in non-compliance with contract provisions, rules, regulations, or laws. The Cherokee Nation procurement and/or contracting offices may maintain a list of entities which have previously provided poor performance or unsatisfactory work or which have engaged in behavior in non-compliance with contract provisions, rules, regulations, or laws.
- B. In accordance with 8.A.5. of this Act the Procurement offices of the Nation and its entities shall maintain a "Debarment List" which shall be a list of contractors which have previously provided poor performance or engaged in behavior in non-compliance with contract provisions, rules, regulations, or laws. Procurement offices shall develop policies and procedures to define poor performance of a contractor / Employer. Documentation of poor performance must be available and provided to the contractor upon request. The Procurement offices shall forward the names of any certified Indian Owned Businesses determined to have poor performances to both the TERO and to the One Stop Business Center for Technical assistance and Improvement.
1. Debarment list , Annual Certification; in compiling the debarment list required by Section 8, Title 40 § 1021, B. the TERO Office shall require, on an annual basis, Employers who employ twenty-five (25) employees or more to certify that they are in compliance with applicable state federal and tribal labor and employment laws. Nothing herein shall impose any new obligation on any employer to comply with said labor and employment laws.
 2. The period of Debarment by the TERO shall be for a period of no less than two years.
- C. In accordance with Section 24 of this Act, the TERO shall address complaints of violations the Act or TERO Rules, should there be any unresolved violations by Departments of the Nation or its Business entities, the TERO shall issue reports of non-compliance to the Principal Chief, Tribal Council and applicable Boards of Directors.

Section 9. Title 40, § 1022 shall read **be amended** as follows:

Indian preference in contracting and subcontracting

In the award of contracts or subcontracts, employers shall give preference to Indian organizations and to Indian-owned economic enterprises as defined in this Title, **unless such preference would be a violation of applicable federal law.** The TERO staff shall maintain and

publish a list of Indian organizations and Indian-owned economic enterprises which shall be supplied to the employers for their use.

Section 10. Title 40, § 1023 shall read be amended as follows:

Preference in promotions

Every employer shall, in accordance with TERO regulations, give Indians preferential consideration for all promotion opportunities and shall encourage Indians to seek such opportunities. Preference will apply as follows (unless federal or state law applicable to that employer prevents such a preference):

- A. Primary preference to Cherokee Nation Citizens
- B. Second preference to other Indians

Section 11. Title 40, § 1024 shall read as follows:

Preference in employment of students

Employers shall give Indian students preferential consideration for summer student employment. The employer shall make every effort to promote after-school, summer, and vacation employment for Indian students.

Section 12. Title 40, § 1025 shall read as follows:

Reserved for Future Use

~~Establishment and review of numerical goals for Indian employment generally~~

- ~~A.—The TERO may establish the minimum number of Indians each employer must employ on its work force during any year that the employer or any of its employees are located or engaged in work within Cherokee Nation Indian Country. Numerical goals may be set for each craft, skill, job classification, etc., used by the employer and shall include, but not be limited to, administrative, supervisory and professional categories. The goals shall be expressed in terms of man hours worked by the employer's work force in the job classification involved.~~
- ~~B.—For both new and existing employers, the goals shall be reviewed by the TERO staff at least annually and shall be revised as necessary to reflect changes in the number of Indians available or changes in employer hiring plans. Each employer shall submit a monthly report to TERO on a form provided by the TERO staff, indicating the number of Indians in the employer's work force, the progress towards the employer's goals, all persons hired or fired during the month, the job positions involved, and other information required by the TERO Office.~~

Section 13. Title 40, § 1026 shall read as follows:

Participation in training programs by employers

Employers may be required by the TERO to participate in training programs to assist Indians to become qualified in the various job classifications used by the employer. The ratio of Indian trainees to fully qualified workers shall be set by the TERO after consultation with the employer.

Section 14. Title 40, § 1027 shall read as follows:

Establishment by TERO staff of counseling and other support programs; Cooperation by employers

The TERO may establish counseling and other support programs to assist Indians in obtaining and retaining employment. Every employer shall be required to cooperate with the TERO regarding such counseling and support programs.

Section 15. Title 40, § 1028 shall read as follows:

Use of job qualification criteria and personnel requirements by employers

Employers are prohibited from using job-qualification criteria or personnel requirements which bar Indians from employment unless such criteria or requirements are required by business necessity.

Section 16. Title 40, § 1029 shall read as follows:

Implementation of layoffs and reductions in force by employers

In all layoffs and reductions in force, employers shall maintain the required ratio of Indian employees.

Section 17. Title 40, § 1030 shall read be amended as follows:

Duties of contractors and subcontractors; Liabilities of employers for violations of by contractors and subcontractors

The Indian preference requirements contained in this Title shall be binding on all contractors and subcontractors doing Projects for ~~of~~ employers (unless applicable federal or state law prevents such a preference), regardless of tier, as referenced in §1021(A)(2) of this Act, and shall be deemed a part of all contract and subcontract specifications. ~~The employer shall be subject to penalties provided herein for violation of this Title if the contractor or subcontractor fails to comply.~~ Any violation of this Act by a contractor or subcontractor of an employer shall subject the contractor or sub contractor to penalties even if the contract does not contain the Indian preference requirement, unless applicable federal or state law prevents such a preference.

Section 18. Title 40, § 1031 shall read as follows:

Establishment and administration of job bank; Recruitment and hiring of personnel by employers

The TERO may establish and administer a Job Bank to assist employers in placing Indians in job positions. An employer may recruit and hire workers from whatever sources are available and by whatever process the employer chooses, as long as the employer complies with this Title and Indian job preference regulations and agreements pertaining to the employer.

Section 19. Title 40, § 1032 shall read as follows:

Prohibition on brokering and fronting services

No Indian entity shall represent that it is exercising management control of a project in order to qualify for Indian Preference in the award of said contract or sub-contract when in fact such management control is exercised by a non-Indian entity such that the Indian entity is acting as front or brokering out services.

Section 20. Title 40, § 1041 shall read as follows:

Duties of unions generally

Every union with a collective bargaining agreement with an employer must file a written agreement stating that the union will comply with this Title and rules, regulations and orders of the TERO. Until such agreement is filed with the TERO, the employer may not commence work within Cherokee Nation Indian Country.

Section 21. Title 40, § 1042 shall read as follows:

Contents of union agreements

Every union agreement with an employer or filed with the TERO must provide:

- A. *Indian preference.* The union will give preference to Indians in job referrals regardless of which union referral list they are on.
- B. *Cooperation with the TERO staff.* The union will cooperate with the TERO Office in all respects and assist in the compliance with and enforcement of this Title and related regulations and agreements.
- C. *Training programs.* The union will establish a journeyman upgrade and advanced apprenticeship program.
- D. *Temporary work permits.* The union will grant temporary work permits to Indians who do not wish to join the union.

Section 22. Title 40, § 1043 shall read as follows:

Model union agreement

The TERO staff will provide a model union agreement for use by all unions who have collective bargaining agreements with any employer.

Section 23. Title 40, § 1044 shall read as follows:

Recognition of unions or endorsement of union activities

- A. Nothing herein, nor any activity by the TERO authorized hereby, shall constitute official Cherokee Nation recognition of any union or endorsement of any union activities within the Cherokee Nation. Nothing herein bars any employer, Cherokee Nation or its entities, from recognizing any union.
- B. Neither the TERO, including any employer or agent thereof, nor any Cherokee Nation entity, shall engage in any activity constituting opposition to or endorsement of any Union activities among employees of any Employer covered by this Act. Nothing herein shall restrain any elected official of the Cherokee Nation from endorsing or opposing such Union activities.
 1. Any prohibition against endorsement of any Union activities in this Section shall not include the provision of any assistance to any Cherokee Nation citizen to utilize any apprentice or job training program operated by any Union or Union affiliated entity.

Section 24. Title 40, § 1052 shall read as follows:

Filing of complaints by TERO and proceedings thereon generally

If the TERO staff has cause to believe that an employer, contractor, subcontractor, or union

has failed to comply with this Title or any rules, regulations or orders of the TERO, it may file a complaint with the TERO Director and notify such party of the alleged violations. The TERO Director will attempt to achieve an informal settlement of the matter, but if an informal settlement cannot be achieved, the TERO may impose penalties as provided in Section 1061 herein. Should any entity fail to comply with orders of the TERO, the TERO may pursue a civil legal action against the entity in the Cherokee Nation District Court.

Section 25. Title 40, § 1053 shall read as follows:

Filing of complaints by Indians and proceedings thereon generally; Penalties for retaliatory actions by employers against employees filing complaints

- A. If any Indian believes that an employer has failed to comply with this Title or rules, regulations or orders of the TERO, or if the Indian believes he or she has been adversely discriminated against by an employer because he or she is Indian, the Indian may file a complaint with the TERO specifying the alleged violation. Upon receipt of the complaint, the TERO shall investigate and attempt to achieve an informal settlement of the matter. If an informal settlement cannot be achieved, the individual or TERO may take further action as provided for by law.
- B. If any employer fires, lays off, or penalizes in any manner any Indian employee for utilizing the individual complaint procedure, or any other right provided herein, the employer shall be subject to the penalties provided in Section 1061 of this Title.
- C. Nothing in this Title shall prohibit the aggrieved Indian from pursuing from the employer other remedies available by law.

Section 26. Title 40§ 1051 shall read as follows:

Conduct of Hearings

If any employer or person feels aggrieved by a decision made by the TERO Office they may appeal that decision to the Employee Appeals Board. Employee Appeals Board shall hold a hearing in accordance with this ACT and will either confirm or deny the TERO Office decision. ~~The Chairperson and Co-Chairperson of the Employment committee of the Tribal Council may attend said hearings as advisory members, but shall not have nay vote in the proceedings.~~

- A. Hearings shall be governed by the following rules and procedure:
 1. All parties may present testimony of witnesses and other evidence and may be represented by counsel at their expense.
 2. The Board may have the advice and assistance at the hearing of counsel provided by the nation
 3. The Chairman of the Board or the vice-chairman shall preside and the Board shall proceed to ascertain the facts in a reasonable and orderly fashion.
 4. The Hearing may be adjourned, postponed and continued at the discretion of the Board.
- B. At the final close of the hearings, the board may take immediate action or take the matter under advisement

- C. The Board shall notify all parties 45 days after the last hearing of its decision in the matter.
- D. The Board shall conclude this process within ninety (90) days of the request for a hearing.

Notice of Hearings

- A. The Employees Appeals Board, as established pursuant to Title 51 Section 1001 et seq. of the Cherokee nation Code Annotated shall have the power and duty to hear employer appeals of TERO decisions denying certification of the employer as an Indian owned economic enterprise. The Employee appeals Board shall have the power to either affirm or reverse the TERO Certification decision, but will not have the power to award any other form of remedy in the cases brought to this title.
- B. The Employee Appeals Board shall have the power to create rules as may be necessary to perform the duties and functions delegated to the Employee Appeals Board herein.
 - 1. If a hearing is requested by ~~at~~ **the** Board, an individual, an employer, or union pursuant to this section, a written notice of the hearing shall be given to all concerned parties stating the nature of the hearing and the evidence to be presented.
 - 2. The notice shall advise such parties of their right to be present at the hearing, to present the testimony of witnesses and other evidence and to be represented by counsel at their own expense.

Section 27 Title 40 § 1072 shall read as follows:

Appeals from decisions of Committee

- A. Any party to a hearing shall have the right to appeal any decision of the Board to the District Courts of the Cherokee Nation
- B. Standard Review. The District Court shall review decisions of the Employee Appeal Board without a jury and shall be confined ~~to~~ **to** the record, except that ~~ineases~~ **in cases** of alleged irregularities in procedure before the Employee Appeals Board, not shown in the record, testimony thereon may be taken by the District Court. The District Court, upon request, shall hear oral arguments and receive written briefs.
- C. Appeals of the decision of the district court may be taken in the Supreme Court under the rules and procedures governing civil appeals before that Court.

Section 28. Title 40, § 1061 shall read- be amended as follows:

Penalties for violations of chapter and rules, regulations or orders of the TERO or Employee Appeals Board

- A. Any employer, contractor, subcontractor or union who violates this Title-or rules, regulations or orders of the TERO shall be subject to penalties for the violation, including, but not limited to:
 1. Denial of the right to commence or continue business within the jurisdiction of the Cherokee Nation.
 2. Suspension of operations within the jurisdiction of the Cherokee Nation.
 3. Payment of back pay and damages to compensate any injured party.
 4. ~~An order to summarily remove employees hired in violation of this Title or rules, regulations or orders of the TERO.~~ **Reserved for Future Use.**
 5. Imposition of monetary civil penalties.
 6. Prohibition from engaging in future operations within the Cherokee Nation boundaries.
 7. An order requiring employment, promotion, and training of Indians injured in the violation.
 8. An order requiring changes in procedures and policies necessary to eliminate the violation.
 9. An order making any other provision deemed necessary to alleviate, eliminate, or compensate for any violation.
- B. The maximum monetary penalty which may be imposed is Five-Thousand-Dollars (\$5,000.00) for each violation. The penalties will be graduated as follows
 1. The first violation will incur a fine of \$200.00
 2. The second violation will incur a fine of \$1,000.00
 3. The third violation will incur a fine of \$5,000.00
- C. Each day during which a violation exists shall constitute a separate violation.
- D. Monetary penalties assessed by TERO may be tripled if it is shown that the violation occurred egregiously or with reckless or wanton behavior.
- E. Attorney Fees and Cost of pursuing or defending an action of the TERO may be awarded to the prevailing party.

Section 29. Title 40, § 1072 shall read as follows:

Time computations

In computing any period of time prescribed or allowed by this Title, the day of the act, default, or event from which the designated period of time begins to run shall not be included. The last day of the period so computed shall be included, unless it is a Saturday, a Sunday, or a legal holiday as defined by the Cherokee Nation or any other day when the receiving office does not remain open for public business until 4:00 p.m., in which event the period runs until the end of the next day which is not a Saturday, a Sunday, or a legal holiday as defined by the Cherokee Nation, or any other day, when the receiving office does not remain open for public business until 4:00 p.m. When the period of time prescribed or allowed is less than eleven (11) days, intermediate Saturdays, Sundays, and legal holidays as defined by the Cherokee Nation or any other day when the receiving office does not remain open for public business until 4:00 p.m., shall be excluded in the computation.

Section 30. Title 40, § 1073 shall read as follows:

Notification of prospective and current employers of obligations imposed by Title and rules, regulations and orders of the TERO

- A. The TERO shall notify all employers of this Title and of the employer's obligation to comply herewith. All bid announcements issued by any tribal, federal, state, or other private or public entity shall contain a statement that the successful bidder will be obligated to comply with this Title and all rules, regulations and orders of the TERO.
- B. All Cherokee Nation agencies responsible for issuing business permits for activities within the Cherokee Nation or otherwise engaged in activities involving contact with prospective employers within the Cherokee Nation shall be responsible for advising such prospective employers of their obligations under this Title and rules, regulations and orders of the TERO.
- C. The TERO shall send a copy of this Title to every employer doing business with the Cherokee Nation.

Section 31. Title 40, § 1074 shall read as follows:

Filing of reports and other information by employers; Conduct of on-site inspections and investigations by TERO; Inspection and copying of records by TERO

- A. Employers shall submit reports, and other information requested by the TERO.
- B. The TERO and its representatives shall have the right to make on-site inspections during regular working hours in order to monitor any employer's compliance with this Title and the rules, regulations, and orders of the TERO.
- C. The TERO shall have the right to inspect and copy all relevant records of any employer, or any signatory union or subcontractor, and shall have a right to speak to workers and conduct investigations on job sites.

Section 32. Title 40, § 1081 to read as follows:

Provisions as cumulative

The provisions of this Title shall be cumulative to existing law except where stated otherwise in this Title.

Section 33. Title 40, § 1082 shall read as follows:

Severability

The provisions of this Title are severable and if any part or provision hereof shall be held void, the decision of the court so holding shall not affect or impair any of the remaining parts or provisions of this Act.

Section 34. Title 40, § 1083 shall read as follows:

Administrative Appeals Board

The Employee Appeals Board, as established pursuant to Title 51, Section 1001, et seq., of the Cherokee Nation Code Annotated, shall hereinafter be known as the "Administrative Appeals Board".

Section 35. Title 40, § 1084 shall read as follows:

Emergency declared

It being immediately necessary for the welfare of the Cherokee Nation, the Council hereby declares that an emergency exists, by reason whereof this Act shall take effect and be in full force after its passage and approval.

Section 36. Title 40 § 1085 shall read as follows:

Applicability

The provisions of this Act shall not apply nor shall compliance be required to the extent such application or compliance may violate applicable federal or state laws. The provisions of this Act shall not apply if such compliance would create a default of a contract by the Cherokee Nation or its entities.

Provisions as cumulative

~~—The provisions of this act shall be cumulative to existing law.~~

Section 37 Title 40 § 1086 shall read as follows:

Reserved for Future Use

Severability

~~—The provisions of this act are severable and if any part of provision hereof shall be held void the decision of the court so holding shall not affect or impair any of the remaining parts or provisions of this act.~~

Section 38 Title 40 § 1087 shall read as follows

Effective Date

The provisions of this act shall become effective thirty (30) days from and after the date of its passage and approval.

Section 39 Title 40 § 1088 shall read as follows

Self-Help Contributions

To the extent that this Act involves programs or services to citizens of the Nation or others, self-help contributions shall be required, unless specifically prohibited by the funding agency, or a waiver is granted due to physical or mental incapacity of the participant to contribute.

Enacted by the Council of the Cherokee Nation on the 10th day of February, 2014.

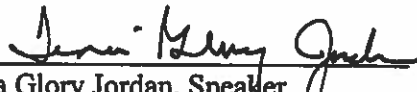
Tina Glory Jordan, Speaker
Council of the Cherokee Nation

ATTEST:

Jodie Fishinhawk, Secretary
Council of the Cherokee Nation

Approved and signed by the Principal Chief this 19 day of Feb., 2014.

Bill John Baker, Principal Chief
Cherokee Nation

ATTEST:

Chuck Hoskin, Jr., Secretary of State
Cherokee Nation

YEAS AND NAYS AS RECORDED:

Tina Glory Jordan	<u>Yea</u>	Janees Taylor	<u>Yea</u>
David Walkingstick	<u>Yea</u>	Dick Lay	<u>Yea</u>
Joe Byrd	<u>Yea</u>	Cara Cowan Watts	<u>Yea</u>
Jodie Fishinhawk	<u>Yea</u>	Harley Buzzard	<u>Absent</u>
Janelle Lattimore Fullbright	<u>Yea</u>	Frankie Hargis	<u>Yea</u>
David W. Thornton, Sr.	<u>Yea</u>	Victoria Vazquez	<u>Yea</u>
Don Garvin	<u>Yea</u>	Julia Coates	<u>Yea</u>
Lee Keener	<u>Yea</u>	Jack D. Baker	<u>Yea</u>
Curtis G. Snell	<u>Yea</u>		



Cherokee Nation
Tribal Employment Rights Office
General Provisions

Legislative Act 01-14



CHEROKEE NATION TRIBAL EMPLOYMENT RIGHTS ACT REGULATIONS

PART 1 GENERAL PROVISIONS

1.1 PURPOSES

The following Regulations are issued by the Cherokee Nation Employment Rights Office pursuant to the authority granted by the Cherokee Nation Employment Rights Act, LA 01-14 §1012 ("the Act"). The purpose of these regulations "is to encourage employment of Indians and to assist in and require the fair employment of Indians and to prevent discrimination against Indians in the employment practices of employers who are doing business with the Cherokee Nation on Cherokee Nation Indian Country or in such jurisdiction as is provided in a cooperative agreement between the Cherokee Nation and another government." LA 01-14, §1003.

1.2 DEFINITIONS

- A. "Administration"** shall mean the Executive Branch of the Cherokee Nation as provided in the Cherokee Nation Constitution.
- B. "Certified Indian Owned Economic Enterprise"** shall mean any Indian-owned economic enterprise certified by the Tribal Employment Rights Committee.
- C. "Cherokee Nation Indian Country"** shall mean the territorial boundaries of the Cherokee Nation as defined within the Cherokee Nation 1999 Constitution, Article II.
- D. "Cherokee Nation Government"** shall mean the officials and employees of the Cherokee Nation and its programs or commissions wherever located. "Cherokee Nation" shall mean the government of Cherokee citizens, authorized by the Act of Union of 1839.
- E. "Contractor"** shall mean any person, company or other entity engaged in work with the Cherokee Nation, its entities or wholly-owned corporations. The term "contractor" includes Cherokee Nation, its entities and wholly-owned corporations, and includes contractors, and subcontractors thereof. This term shall not include federal, state, or county government agencies to the extent prohibited by federal or state law.
- F. "Core crew"** shall mean an owner of the firm, or an employee of a company who is in a supervisory or other key position such that the employer would face a serious financial damage or loss if that position were filled by a person who had not previously worked for the employer contractor or subcontractor.
- G. "Council"** shall mean the Tribal Council of the Cherokee Nation as established pursuant to the Cherokee Nation Constitution.

- H. **"Non-Compliance List"** shall be a list of contractor/ employers which have previously engaged in behavior in non-compliance with contract provisions, rules, regulations, or laws.
- I. **"EEOC"** shall mean the Equal Employment Opportunity Commission of the United States.
- J. **"Emergency"** means any condition that places an extreme physical or emotional condition or financial burden on a Cherokee Citizen. (After all reasonable efforts have been made to contact a TERO Vendor)
- K. **"Employer"** shall mean (i) Cherokee Nation, its entities and wholly-owned corporations, (ii) any person, company, contractor, subcontractor or other entity engaged in work on a project with the Cherokee Nation, its entities or wholly-owned corporations or (iii) any person or entity employing two or more persons located within Cherokee Nation Indian Country that has applied for or received certification with the TERO Office. The term "Employer" shall not include companies that are engaged in government Contracting or other activities where the application of this law may violate applicable federal or state laws.
- L. An employer is **"engaged in work"** if, during any portion of a business enterprise or specific project, contract or subcontract, the employer performs work under contract with the Cherokee Nation, its entities and wholly-owned corporations and/or the work is performed on Cherokee Nation Indian Country.
- M. **"Indian"** shall mean a person who is a member of a federally recognized Indian tribe.
- N. **"Indian-owned economic enterprise"** shall mean any Indian-owned commercial, industrial, or business activity established or organized for the purpose of profit, provided that such Indian ownership shall constitute not less than 51 percent (51%) of the enterprise, and the ownership shall encompass active operation and control of the enterprise.
- O. **"Indian Tribe"** means an Indian Tribe, pueblo, band, nation, or other organized group or community, including any Alaska Native Village or regional or village corporation as defined in or established pursuant to the Alaska Native Claims Settlement Act (85 Stat. 688, 43 U.S.C. § 1601), which is recognized as eligible for the special programs and services provided by the United States to Indians because of their status as Indians.
- P. **"Locally Owned"** means a business that has its headquarters and majority of its employees residing within the jurisdictional boundaries of the Cherokee Nation, as described in Article II of the Cherokee Constitution, or counties contiguous to those boundaries.

- Q. An employer is "**located within Cherokee Nation Indian Country**" if, during and in connection with any portion of a business enterprise or specific project, contract or subcontract, the employer maintains a temporary or permanent office or facility on or performs work on Cherokee Nation Indian Country.
- R. "**Major Cherokee Employer**" shall mean an Indian owned business that employs at least 50 Cherokee Citizens as either part of the core crew or project crew, or has at least 75% of its workforce comprised of Cherokee Citizens as certified by the TERO. A business may be certified as Indian Owned, major Cherokee Employer, or both.
- S. "**Nation**" shall mean the Cherokee Nation.
- T. "**One Stop Business Center**" means a centralized location where Cherokee Owned businesses can obtain information regarding procurements, training, and financing.
- U. "**Secretary**" shall mean the United States Secretary of the Interior or his or her duly authorized representatives.
- V. "**Tribal Citizen**" shall mean any person who is a duly enrolled member of the Cherokee Nation.
- W. "**TERO**" shall mean the Tribal Employment Rights Office.
- X. "**TERO Staff**" shall mean employees assigned to the TERO Office by the Executive Branch of the Cherokee Nation.
- Y. "**Project**" shall mean any construction, alteration, or repair of buildings or structures performed for Cherokee nation or its entities.

1.3 TERO AUTHORITY

The TERO has the authority granted under LA 01-14 §1011:

- A. To operate consistent with the provisions of these regulations. The TERO may adopt EEOC guidelines or may adopt other requirements to eliminate employment barriers unique to Indians in Indian Country.
- B. To obtain funding from Federal, state and other sources to supplement Council appropriations as delegated by the Administration.
- C. To negotiate cooperative agreements with federal, state, local, and other authorities on matters dealing with employment rights and TERO activities and to operate pursuant to finalized cooperative agreements and/or memoranda of understanding or agreement.

- D. To use the information, facilities, personnel, and other resources of federal, state, and local agencies, as allowed by those agencies, as well as any and all Cherokee Nation departments.
- E. To require employers to establish or participate in job training programs as the TERO deems necessary to increase the pool of Indians eligible for employment.
- F. To establish and administer a tribal job bank and require employers to use it.
- G. To prohibit employers from using job-qualification criteria or personnel requirements that may bar Indians from employment unless such criteria or requirements are required by business necessity.
- H. To engage in the process of certifying businesses as "Indian-owned economic enterprises" and to determine whether businesses may be given Indian preference.
- I. To direct inspections of regulated sites and determine compliance with rules, regulations, and/or contract requirements. A "regulated site" shall be any site where an Employer is engaged in work as defined by the Act.
- J. To negotiate agreements with unions to insure union compliance with this Title.
- K. To require employers/contractors to follow the preferences as required in §1021.
- L. To establish counseling programs to assist Indians in obtaining and retaining employment.
- M. To require employers to submit reports and take all actions deemed necessary by the TERO for the fair and vigorous implementation of the Act.
- N. To enter into cooperative agreements with employment rights agencies such as EEOC and OFCCP to eliminate adverse discrimination against Indians.
- O. To take such actions as are necessary to achieve the purposes and objectives of the Cherokee Nation employment rights program established in the Act.
- P. To publish a listing of certified "Indian-owned economic enterprises."
- Q. To review and propose changes to the Act and related regulations as necessary.
- R. To participate and cooperate in appeal hearings in accordance with the Act.
- S. To register and keep file of records and complaints concerning certified Indian-owned economic enterprises and with individuals and companies doing business with the Cherokee Nation.
- T. To assess an employment rights fee of one-half (1/2) of one percent (1%) on all covered contracts, which shall mean any contract executed by a contractor as defined in Title 40, §1004.

- U.** To issue and assess fees for Work Permits which must be obtained for all non-Indian employees of an employer.
1. Any employer, as defined in this act shall be required to pay a fee of not less than Twenty-five dollars per employee per day for non-Indian employees hired for a Project or hired after the effective date of Legislative Act 30-12 if the Employer is the Cherokee Nation or its entities.
 2. Each such employer shall be required to submit a core crew list to the TERO.
 3. Once the core crew list is submitted the TERO will confirm the core crew members the vendor has listed and those employees shall not be exempt from the requirement to obtain a Work Permit but no fee will be due for the core crew employees.
 4. If the TERO has identified Indians that can be used for non-Indian Employees it shall submit the name to the Employer for consideration of replacement of the non-Indian Employees. Failure to hire the qualified Indians submitted by TERO may result in termination of the Employer's contract with the Cherokee Nation or its entities.
 5. The TERO is also authorized to administer other fees and penalties as provided in the Act.
 6. An Employer is exempt from the assessment of a fee or penalties as provided in the Act if the Employer can prove to the TERO that the Employer followed the preferences under the Act through posting of a job announcement twice, Employer submits job descriptions to TERO for qualified Indians, and through proof that no Indian applicant was qualified or no Indian applied

PART 2
TERO POLICIES AND GUIDELINES

The following rules policies and guidelines shall be implemented by the TERO to comply with the authority granted under LA 01-14 §1011:

2.1. CORE CREW (PERMANENT AND KEY EMPLOYEES)

- A.** Prior to commencing work on a project on Cherokee Nation Indian Country or with the Cherokee Nation, prospective employers and all subcontractors of employers shall identify key, regular, permanent employees (core crew). It shall not include persons hired on a project-by-project basis. For Cherokee Nation entities, such list shall be provided upon approval of these regulations and updated when core crew are replaced. Cherokee Nation shall be exempt from this requirement based upon federal law or regulations.

- B.** A key employee is one who is in a top supervisory position or performs a critical function such that an employer would risk likely financial damage or loss if that task were assigned to a person unknown to the employer. The fact that an employee has worked for the employer on previous projects shall not qualify that employee as a regular, permanent employee; provided, that exceptions for superintendents and other key personnel who are not permanent, regular employees may be granted by the TERO Director/Compliance Officer on a case-by-case basis. Any employer or subcontractor of an employer which fills vacant employment positions in its organization immediately prior to undertaking work pursuant to a contract to take place on Cherokee Nation Indian Country or with the Cherokee Nation shall set forth evidence acceptable to the TERO Director that its actions were not intended to circumvent these requirements. Upon its approval of each key or permanent regular employee requested by the employer, the TERO shall issue a permit to that worker. For Cherokee Nation entities, key employee shall mean all chief executives for the entity.

2.2. WORK PERMITS

- A.** All employers shall obtain work permits for their employees prior to commencing work.
- B.** A fee of \$25.00 per day fee will be assessed for the work permit for all non-Indian employees unless such employee meets one of the following exemptions:
 - 1.** All Cherokee Nation Employees, based on federal law and/or regulations;
 - 2.** Cherokee Nation Entity Employees hired prior to the effective date of LA 30-12 or Cherokee Nation Entity Employees if the application of the fee, which is based on Indian preference, would create a violation of federal law or regulation or would create a violation of a federal contract;
 - 3.** Core Crew Members of employers as determined by the TERO; or

4. Non-Indians hired after due diligence by employer as required by LA 01-14 §1011(U) 6.

2.3. JOB QUALIFICATIONS, PERSONNEL REQUIREMENTS, AND RELIGIOUS ACCOMMODATIONS

- A. An employer may not use any job qualification criteria or personnel requirements which serve as barriers to the employment of Indians and which are not required by business necessity. The burden shall be on the employer to demonstrate to the TERO that such criterion or requirement is required by business necessity. If the employer fails to meet this burden, he will be required to eliminate the criterion or personnel requirement at issue. Employers shall make reasonable accommodation to the religious beliefs of Indian workers.
- B. Where the TERO and employer are unable to reach agreement on the matters covered in this section, a hearing shall be held, as provided for in these Regulations. The TERO Director shall make a determination on the issues and shall order such actions as he/she deems necessary to bring the employer into compliance with this section. The employer may appeal the decision of the TERO Director under the procedures provided for in Section 5.3 of these Regulations.

2.4. COUNSELING AND SUPPORT PROGRAMS

The TERO, in conjunction with other Tribal and Federal offices, will provide counseling and other support services to Indians employed by employers to assist such Indians in obtaining and retaining employment. Employers shall be required to cooperate with such counseling and support services.

2.5. LIST OF CERTIFIED FIRMS

The TERO shall maintain a list of Certified Indian Owned Economic Enterprises and shall publish such list. An entity may obtain a list of firms certified as Indian preference eligible from the TERO. The TERO shall identify such firms according to the order of preference set out in LA 01-14 § 1021, A, 2, d.

2.6 REPORTS AND MONITORING

- A. All employers/contractors engaged in any aspect of business activity on Cherokee Nation Indian Country or with the Cherokee Nation or its entities shall submit reports and such other information as is requested by the TERO. Employees of the TERO shall have the right to make on-site inspections during regular working hours in order to monitor an employer/contractor's compliance with these Regulations. Employees of the TERO shall have the right to inspect and copy all relevant records of an employer/contractor, of the employer/contractor's signatory unions or subcontractors, to speak with workers on the job site, and to engage in similar investigatory activities. All financial and/or proprietary information collected by the TERO shall be kept confidential, unless disclosure is required during a hearing or appeal as provided for in these Regulations.

- B.** Each certified firm shall report to the TERO, in writing, any changes in its ownership or control status within 30 days after such changes have occurred. Each certified firm, on the anniversary of its receipt of permanent certification, shall update the information provided in its initial application on an Annual Report form provided by the TERO. Failure to provide information pursuant to these requirements shall constitute grounds for withdrawal of certification.

2.7 DISSEMINATION

The obligation of all employers/contractors to comply with the Tribal Employment Rights Requirements shall be made known to all existing and future employers/ contractors. All bid announcements issued by employer/ contractors shall contain a statement that the successful bidder will contract to comply with these Regulations and that a bidder will contact the TERO to obtain additional information. Those tribal and other offices engaged in activities involving contact with prospective employers/ contractors shall be responsible for informing such prospective employers/ contractors of their obligations under these Regulations or directing them to the TERO for information.

2.8 APPLICABILITY

These provisions shall not apply nor shall compliance be required to the extent such application or compliance may violate applicable federal or state laws. These provisions shall not apply if such compliance would create a default of a contract by the Cherokee Nation or its entities.

PART 3
CERTIFICATION OF INDIAN-OWNED ECONOMIC ENTERPRISES

3.1 CERTIFICATION PROCEDURE

- A.** A firm seeking certification as an Indian-owned firm shall submit a completed application to the TERO on the form provided by the TERO. The firm will also include a check or money order for one hundred dollars (\$100.00) made payable to the Cherokee Nation TERO. This is non-refundable.
- B.** Applications may be requested from the TERO and received from the TERO by mail or fax, or may be downloaded from the TERO website.
 - 1.** The TERO staff will provide assistance to the firm in filling out the application when requested.
 - 2.** The TERO staff will stamp the date received of each application as it is received.
 - 3.** Once received, the application will be logged in and reviewed by a designated TERO staff.
 - 4.** When an application is submitted, the TERO shall provide the applicant with notice of the Act and the Regulations. Such notice shall explain that if certified, the Act and the Regulations will apply to the applicant and the applicant is submitting to regulation under the Act. In addition, the notice shall include the applicant's right to withdraw the application if they are not willing to comply with the requirements in the Act.
- C.** Once the application is deemed complete, a TERO staff member will schedule a site visit with the vendor if feasible.
- D.** Once the site visit is completed, the application will be given to the TERO Director for review.
- E.** After review, the TERO Director will recommend approval, denial, or interview.
 - 1.** If the recommendation is denial, concerns will be listed and the vendor will be contacted for additional information or clarification.
 - Once these concerns are addressed, the application will be placed on the agenda for the next scheduled Certification Committee meeting, if the vendor wishes to proceed.
 - 2.** If the recommendation is approval or interview, the application will be placed on the agenda for the next scheduled Certification Committee meeting.
- F.** Members of the Certification Committee will receive a copy of the agenda and the listed applications the day before the scheduled meeting in order to ensure a thorough review of the applications prior to the meeting.
- G.** During the Certification Committee meeting, the committee will review all applications and vote to recommend the application be approved or placed in

pending for an interview. The committee will base their decision on the criteria discussed in Section 3.2 of these provisions.

1. The Indian principal(s) of the firm must be present at the interview. In addition, any other party wishing to present information to the Committee shall be entitled to do so, by requesting, no less than one day prior to the hearing, an opportunity to participate. A party may not be represented by counsel.
2. The Certification Committee will meet on the first Tuesday of every month unless that day falls on a Holiday or if the committee is unavailable to establish a quorum. The committee will reschedule the meetings at its earliest convenience.
3. If placed in pending for interview, the vendor will be contacted by the TERO and scheduled to come before the Certification Committee at the next scheduled Certification Committee meeting.
4. After the interview, the Certification Committee will either recommend approval or denial of the application, or may retain in pending for additional documentation.

H. The TERO will send a one-year probationary certificate to the vendor and they are added to the TERO certified vendor list after approval from the Tribal Council.

1. During probationary period, the TERO shall monitor the firm's activities to ensure that the firm is operating in the manner described in its application. During the probationary period, the TERO and the Committee shall have the right to request and receive such information and documents as they deem appropriate.
2. After the one-year certification, the vendor is notified that it is time to renew and requested to submit the recertification form and applicable documentation. (See procedure for recertification.)
3. At the end of the probationary period, the Committee, after receiving recommendations from the TERO, shall either:
 - a. Grant full certification with annual recertification;
 - b. Continue the probationary period for up to six months; or
 - c. Deny certification.

I. If the application is denied the TERO will send a letter to the vendor informing them of their right to appeal the decision. In addition, the letter will notify the applicant that they cannot reapply for one year from the date of denial.

J. If the TERO does not receive any contact by the vendor within six months of request for documents or interview, the application will be denied and no further action will be taken with the application. Once denied, the applicant must file a new application and application fee before the application will be considered but the applicant will not be required to wait one year to reapply.

- K.** All decisions must be approved by the Executive Director.

3.2 RECERTIFICATION PROCEDURE

It is the policy of the TERO to review each vendor annually to ensure the vendor meets the criteria to continue to be a certified Indian-owned business.

- A.** The TERO will mail each vendor a notification letter and recertification form annually to inform the vendor it is time to renew.
- B.** The vendor will be placed on the TERO Committee agenda for recertification.
- C.** Once the TERO Committee affirms the TERO recertification request, the TERO will request the \$50.00 fee and a copy of the most recent business tax return.
- D.** Once the payment and Tax Return has been received the TERO will verify Indian ownership of the business.
- E.** Additional site visits may also be conducted by the TERO staff.
- F.** If the vendor is deemed eligible, a new one-year certification certificate will be mailed to the vendor after approval by the Tribal Council.
- G.** If the vendor is not eligible, the TERO will send a letter to the vendor informing them of the vendor being dropped from the TERO list, or request that the vendor interview with the Certification Committee.
- H.** Vendors will be granted a 90 day grace period once the certificate has expired to comply with TERO to determine eligibility.
 - 1.** The vendor will be mailed a certified letter informing the vendor that they will be dropped from the TERO list in 15 business days unless they respond to the TERO.
 - 2.** After 15 days from notification, the business will be removed from the listing.
 - 3.** Any vendor who bids using an expired certificate will receive no preference.
 - 4.** A certified letter will be mailed to the vendor informing them of their business being dropped from the TERO list.

3.3 CRITERIA FOR INDIAN-OWNED ECONOMIC ENTERPRISE CERTIFICATION

To receive a certification as an Indian-Owned Economic Enterprise, an applicant must satisfy all of the criteria set out in this section.

A. Ownership

The firm must be 51% or more Indian-owned. The applicant must demonstrate the following:

1. Formal Ownership

That an Indian or Indians own(s) 51% or more of the partnership, corporation or other arrangement for which the application is being submitted. Such ownership must be embodied in the firm's organic documents, such as its stock ownership or partnership agreement.

Ownership Includes:

- a. Financial ownership—i.e., the Indian(s) own 51% or more of the assets and equipment, will receive 51% or more of the firm's assets upon dissolution, and will receive 51% or more of the profits; and
- b. Control—i.e., the Indian(s) 51% or more ownership provides him or her with a majority of voting rights or decisional authority and that all decisions of the firm are to be made by a majority vote except where otherwise required by law.

2. Value

The Indian owner(s) provided real value for his or her 51% or more ownership by providing capital, equipment, real property or similar assets commensurate with the value of his or her ownership share. It will not be considered "real value" if the Indian(s) purchased his or her ownership share, directly or indirectly, through a promissory note, the ultimate creditor of which is the non-Indian owner of the firm or an immediate relation thereof, or any similar arrangement, unless a convincing showing can be made that the Indian owner(s) brought such special skills, marketing connections or similar benefits to the firm that there is a good reason to believe the arrangement would have been entered into even if there was not an Indian Preference Program in existence. Where the Indian participant can demonstrate that he or she could not pay good value for his or her 51% or more Indian ownership because the normal capital sources were closed to him or her because he or she is an Indian, that person may satisfy this requirement by demonstrating further that her or she extended his or her capital-raising capability as far as possible, such that the Indian participant clearly is at risk in the business in relationship to his or her means.

3. Profit

The Indian owner(s) will receive 51% or more of all profits. If there is any provision that gives the non-Indian owner a greater share of the profits, in whatever form and under whatever name, such as through management fees, equipment rental fees, or bonuses tied to profits, certification will be denied. Salary scales will be reviewed to ensure the relative salaries being paid Indian and non-Indian owners are consistent with the skills of the parties and are not being used to circumvent the requirement that Indian owners receive 51% or more of the profits.

B. Management Control

The Firm must be under significant Indian management and control. The firm must be able to demonstrate that:

1. One or more of the Indian owners must be substantially involved, as a senior level official, in the day-to-day management of the firm. The Indian owner does not have to be the "Chief Executive Officer". However, he or she must, through prior experience or training, have substantial occupational ties to the area of business in which the firm is engaged such that he or she is qualified to serve in the senior level position and is sufficiently knowledgeable about the firm's activities to be accountable to the Tribe for the firm's activities. The provision may be waived when:
 - a. The firm is 100% Indian owned and the Chief Executive Officer is the spouse and/or parent of the owner(s) and the family lives within or near the historical boundaries of the Cherokee Nation, and the majority of employees are Indian; or
 - b. The firm is modeled on a publicly-held corporation such that it is owned by 10 or more persons and it is at least 70% Indian owned, the Chief Executive Officer and the highest salaried employee in the firm is/are Indian, and majority of the employees are Indian.
2. No joint ventures will be certified.

C. Integrity of Structure

There must be good reason to believe that the firm was not established solely or primarily to take advantage of the Indian Preference Program and in questionable cases certification will be denied.

1. History of the Firm

Whether the history of the firm provides reason to believe it was established primarily to take advantage of the Indian Preference Program, and in particular whether the firm, a portion of the firm, or key actors in the firm originally were associated with a non-Indian owned business that gained little

of business value in terms of capital, expertise, equipment, etc., by adding ownership or by merging with an Indian firm.

2. Employees

- a. Whether key non-Indian employees of the applicant are former employees of a non-Indian firm with which the Indian firm is or has been affiliated, through a joint venture or other arrangement, such that there is reason to believe the non-Indian firm is controlling the applicant.
- b. Whether Indians are employed in all or most of the positions for which qualified Indians are available. A high percentage of non-Indian employees in such positions will provide reason to believe the firm was established primarily to benefit non-Indians.

3. Relative Experience and Resources

Whether the experience, expertise, resources, etc., of the non-Indian partner(s) is so much greater than that of the Indian(s) that there is little sound business reason for the non-Indian to accept a junior role in the firm or venture other than to be able to take advantage of the Indian Preference Program.

D. Brokers

Brokers will be certified only if they are dealers who own, operate or maintain a store, warehouse or other establishment in which the commodities being supplied are bought, kept in stock and sold to the public in the usual course of business; Provided, that this requirement shall not apply where the applicant demonstrates that it is customary and usual in the area of trade for a broker/dealer not to maintain an establishment and to keep the commodities in stock.

3.4. WITHDRAWAL OF CERTIFICATION

- A. On the basis of written grievance filed by any other firm or person, or on its own initiative, the TERO may initiate proceedings to withdraw or suspend the certification of any firm. The TERO shall prepare an analysis and recommend disposition for the Committee and shall send the firm notice, by registered mail, that its certification is being examined, along with the grounds therefore. The Committee shall then set a date for a hearing, which shall be held within 21 days after it receives the analysis and recommended disposition from the TERO. At the hearing, the TERO shall present the case for suspension or withdrawal. After the hearing, the Committee may:
 1. Withdraw Certification;
 2. Suspend certification for up to one year;
 3. Put firm on probation; and/or

4. Order corrective action be taken within a fixed period. A firm that has had its certification withdrawn may not reapply for a period of two years.
- B.** All decisions made by the committee or the TERO are subject to approval by the Executive Director.

**PART 4
FEES**

4.1. PROVISION FOR COLLECTION OF FEES

- A.** Except as provided in Section 4.2,A, all fees are due and shall be paid in full by any employer/ contractor prior to his or her commencing work, unless other arrangements are agreed to, in writing, by the Director.
- B.** Immediately upon becoming aware that an employer/ contractor is intending to engage in work with the Cherokee Nation or its entities, the TERO shall contact said employer/ contractor informing him or her of the nature and purpose of the fee, the percentage, the specific amount due, if known, the date due, and the possible consequences if the employer/ contractor fails to comply. Said notice shall be accompanied by a formal notice of fees due (invoice).
- C.** If the employer/ contractor fails to pay the fee by the day it commences work on Cherokee Nation Indian Country or with the Cherokee Nation or its entities, the TERO may direct that work cease on the project until the fee is paid and/or may issue an Order of Non-Compliance.
- D.** Where the Director or Committee has reasonable cause to believe that an employer/ contractor will flee the jurisdiction before the procedures set out above can be completed, they may apply any of the procedures provided for in the Act, notwithstanding the above procedures.

4.2. ALTERNATIVE ARRANGEMENT

- A.** The Director, in his direction, may, upon receipt of a written request, authorize an employer/ contractor to pay the required fees in installments over the course of the year or the contract, as appropriate, when:
 - 1. The total annual fees exceed \$5,000.00; and
 - 2. The employer/ contractor demonstrates hardship or other good cause.
- B.** The decision to authorize an alternative arrangement, which shall be in writing, shall rest solely with the TERO Director.

**PART 5
COMPLAINTS**

5.1 COMPLAINT PROCEDURES

- A. Any party who has the ability to file a complaint under LA 01-14 for failure to comply with these Regulations, or the Law, may file a complaint with the TERO.
- B. Once a written complaint is received by the TERO, the TERO shall notify the alleged violating party of the complaint and shall allow said party to provide a written rebuttal statement. The TERO will do the necessary investigation to determine if the complaint is valid.
- C. The TERO will attempt to achieve an informal settlement of the matter. If voluntary conciliation cannot be achieved and the Director has reasonable cause to believe a party has violated the Act or Regulations, the Director shall issue a formal notice of non-compliance to the party and an Order for how to comply with the law. Failure to comply with the Order of TERO may subject the party to penalties. Such penalties may be assessed by the TERO after consultation with the Office of the Attorney General and approval by the Executive Director.
- D. If any employer, contractor, or person feels aggrieved by a decision made by the TERO Office they may appeal that decision to the Employee Appeals Board.

5.2 APPEALS

The decision of the Committee or TERO will be subject to appeal as provided for in the Cherokee Nation Tribal Employment Rights Act. The Party appealing shall pay the fee to file the appeal. If the appealing party is successful and a decision of the committee or TERO is overturned, then TERO shall reimburse the filing fee to the successful party.

Approved:



TERO Director

7/15/14
Date



Executive Director for Career Services

07/15/14
Date



Secretary of State

7/15/14
Date



GWYB DBF
CHEROKEE NATION®
P.O. Box 948 • Tahlequah, OK 74465-0948 • 918-453-3000 • cherokee.org

Office of the Chief

Bill John Baker
Principal Chief
ᎠᎩ ᎠᎩᎩᎩᎩᎩ
ᎠᎩᎩᎩᎩ

S. Joe Crittenden
Deputy Principal Chief
ᎠᎩ ᎠᎩᎩᎩᎩᎩ
ᎠᎩᎩᎩᎩ ᎠᎩᎩᎩᎩᎩ

Tribal Employment Rights Office PROJECT LABOR AGREEMENT Master Agreement LA 01-14

DURATION

This agreement shall be in effect from _____ to _____ 20____

This agreement is entered into by and among the Cherokee Nation Tribal Employment Rights Office (TERO) and _____ selected contractor for _____ project.

PURPOSE AND SCOPE

This agreement applies to any new project on the Cherokee Nation Jurisdictional area. It represents a concerted effort among the parties to provide opportunities for employment; to provide safe, healthy, and clean working environments and working conditions; to provide ongoing apprenticeship, training, employment, and career path opportunities.

TRIBAL SOVEREIGNTY

All federally recognized Indian Tribes possess inherent sovereign jurisdiction and authority over their territories and the affairs of the tribes and all parties signatory to this agreement acknowledge that the sovereign authority governs the terms of this agreement. The parties agree that the sovereign immunity and authority of the Tribes shall remain intact and unabridged throughout the life of this agreement and that the Cherokee Nation shall decide all issues regarding tribal sovereignty and their decision shall be both final and binding.

TERO RECOGNITION

The Cherokee Nation has adopted a Tribal Employment Rights Ordinance (TERO). The contractor, its appointed agents and all other parties agree to recognize the rights, responsibility and authority and agree to abide by the TERO regulation or determination. The parties recognized that TERO has a primary commitment to the employment of Indian tribal members and the hiring of Indian preference employees.

INDIAN PREFERENCE WORKERS

The contractor agrees that it shall adhere to the following numbers established by the TERO, for this project only. In its effort to create the economic opportunities for Native Americans and to meet the purpose of the TERO act, the TERO has established that 100% of the unskilled labor positions be filled by Native Americans. The contractor and its agents agree to utilize the TERO Job Bank to the fullest extent giving first hire priority rights to all Cherokee Citizens. If, after documented evidence that, the contractor has exhausted all avenues to fill these labor positions with Native Americans and positions remain unfilled, the contractor shall have the right to seek other applicants from whatever source it chooses. The contractor shall supply the TERO with written documentation of the employees hired for this project before work is to begin. This documentation is to include: position for which employee was hired, date of hire, and rate of pay. The contractor further agrees to adhere to the requirements set forth in Section 16 Title 40 § 1029 of the Cherokee Nation TERO Act, which addresses procedures in the event of a layoff or reduction in force.

WORK PERMITS

No person who is not a member of a federally recognized tribe shall be employed by a covered employer until he or she has obtained a work permit from the TERO at a cost of twenty-five dollars (\$25) per day, per permit. Work permits issued under this agreement are valid only for this covered project. If any non-Indian individual employed on this project is found not to possess a work permit issued by the TERO, he/she may be summarily removed from the project and the employer shall be subject to additional sanctions.

TERO FEES

TERO has been given authority by the TERO law specifically Section 5. Title 40 § 1011(T), to charge an employment rights fee of ½ of 1% of the total project cost on every contract that is awarded to any covered employer. These fees will assist the TERO department in its effort to fulfill its responsibilities in creating opportunities for Native Americans, for example, establishing training programs that will give Native Americans the chance to learn a new skill or upgrade current skills. No contractor may commence work on a project until this fee has been paid to the TERO

OTHER SPECIFIC REQUIREMENTS

The contractor further agrees to allow the TERO staff to monitor projects unannounced during normal business hours and to provide full cooperation and any requested documentation to the TERO staff member performing the monitor visit. The Contractor shall provide the TERO with a Core Crew List for this project before work begins.

ENFORCEMENT AND REMEDIES

Any employer, contractor, or subcontractor, who violates any part of this agreement, shall be subject to the remedies set forth in Section 28, title 40 §1061 of the Cherokee Nation TERO act.

For the Contractor:

For TERO:

Signature

Signature

Title

Title

Date

Date

Address

E-mail

Phone #

Jobsite Contact



Core Crew / Project Workers List
For Cherokee Nation Construction Projects
TERO



Contractor:

Sub Contractor:

Project Name:

Location:

Phone #

E-mail:

Core Crew	Name	Position	ID #	Native (Y/N)
EXEMPT As defined in Legislative Act 01-14, section 4, E		Owner		
		Project Manager		
		Supervisor		
Project Crew	Name	Position		Native (Y/N)

Contractor Signature: _____ Tero Staff Signature: _____

Estimated Start Date: _____ Date: _____

Cherokee Nation Tribal Employment Rights Office

Project Labor Fees

Name of Contractor or Sub Contractor		Business Contact									
		Address									
		Phone									
		E-mail									
For Week Ending		Project Name & Location									
(1.) Name of individual and identifying number e.g. Last four digits of social security number	(2.) Indian	(3.) Non-	(4.) Day and Date worked							(5.) Total Days Worked	(6.) Total Fees
			Mon	Tue	Wed	Thur	Fri	Sat	Sun		
(7.) TOTAL \$											

I, _____ do hereby state that the above listed individuals worked on the _____ project during the period commencing on _____ and ending on _____. During this period _____ employed _____ Indians and _____ non Indians on said job site.

Signature Title Date

List Compliance Officer _____

Code of Conduct for Cherokee Nation Entertainment Jobsites

Cherokee Nation Entertainment (CNE) intention is to provide a job site that does not disrupt everyday life and that every Cherokee citizen will be proud to have in their city.

“To Our Contractors and Their Subs:

Cherokee Nation Entertainment wants to ensure that the professionals who work on Cherokee Nation Entertainment facilities and the jobs they perform deserve our respect. Cherokee Nation Entertainment encourages contractors to read and review how these Codes apply to you and your team and expects all contractors to inform and make available this Code of Conduct, as it applies to all who work for Cherokee Nation Entertainment.

Working for Cherokee Nation Entertainment

Each worker must agree to this Code in writing prior to working on any Cherokee Nation Entertainment construction projects. The agreement is to be turned over to the CNE project manager their first work day on the job site.

Objective

To provide a safe, respectable, and professional working environment for everyone on the construction team, Claremore community, and citizens of the Cherokee Nation through the established guidelines for construction site team members.

1. While working on any Cherokee Nation Entertainment project, any findings of possible artifacts shall be left in the place discovered, undisturbed, and reported to the CNE project manager immediately. All work around the finding will stop until the project manager makes a determination as to what the next course of action will be and will notify the contractor.
2. CNE requires that all properties under construction and surrounding properties that have been affected by the CNE construction project (building, lawn, and entire job-site) be left in better condition than you found it. Treat the Cherokee Nation’s property better than your own.
3. Smoking is STRICTLY PROHIBITED on Cherokee Nation Entertainment construction projects at all times (indoors and outdoors). Smoking at lunch, or during break, must be confined to off the construction site premises or inside your vehicle. Under no circumstances shall smoking debris (butts) be discarded on the ground. Take them with you!
4. Bathroom facilities shall be respected and not abused, and the facilities shall be left as clean as, or cleaner than found. Designated temporary restrooms (porta-potty) will be provided for certain job-sites. Anyone reported using the restroom in public (e.g. behind a building, near a tree) will be asked to leave the site immediately.
5. Finished floors in or paths of access/egress shall be covered for protection.
6. Job site shall be left broom-clean at the end of each work day. Debris shall be cleaned up and excess debris removed from site. All trades are responsible for the removal of the own debris on a daily basis.
7. At the conclusion of each work day, tools shall be disconnected, placed in a designated area, and the customer notified accordingly. Every precaution shall be made to prevent outside parties from accessing tools or dangerous items.
8. Profanity is STRICTLY PROHIBITED on or near Cherokee Nation job-sites and property. Expect that all things spoken can be overheard by others at all times.
9. Service entrances shall be used whenever possible. Front doors and formal rooms shall be avoided whenever possible.

10. Children shall not be allowed on job sites at any time.
11. Whenever possible and practicable, construction vehicles shall be parked on or in designated parking areas in such a fashion as to not obstruct owner's access or egress to property. However, unloading activity is permitted and shall be completed as expeditiously as possible.
12. Offensive clothing (revealing, dirty or containing offensive graphics or language) is prohibited at all times. Inappropriate messages or images will not be tolerated on T-shirts, hard hats, tool boxes etc. Construction personnel will be required to cover any existing offensive material.
13. Food debris and wrappers from breaks and lunch shall be immediately placed in appropriate containers.
14. All changes in the scope of work are to be immediately reported to a construction representative of Cherokee Nation Entertainment and are not to be executed without approval from a Cherokee Nation Entertainment representative (Project Manager).
15. Anyone that visits a Cherokee Nation Entertainment job site are to be formally addressed (e.g. Mr. Smith, Ms. Smith) unless specifically directed otherwise by visitor. Projects are subject to visits by Cherokee Nation council members, CNE board members and CNE executive management at any time.
16. Use or possession of illegal drugs or alcoholic beverages is STRICTLY PROHIBITED at all times during the work day. All Cherokee Nation Entertainment job sites and facilities are drug, alcohol and tobacco free workplaces. Drug, alcohol and/or tobacco use at any time while working on CNE projects shall be grounds for IMMEDIATE DISMISSAL! Smokeless tobacco and spitting are prohibited too.
17. All job sites shall be secured at the end of each work day. The job site will not be left unattended by construction personnel if it's unlocked and/or unsecure. The CNE project manager must be notified if the site cannot be locked and secured. Once the job site is locked and secured all parties involved can leave the job site.
18. Proper work attire will be worn at all times by construction personnel. No shorts are allowed. Shirts without sleeves are not allowed.
19. Precautions will need to be made to prevent any damage to existing buildings and site facilities. Workers need to remember that the residents of the adjacent buildings are members of the community and Cherokee citizens. How the construction project affects their daily life will be taken into consideration.
20. Construction workers will carry out their work activities and avoid impacts (dirt, mud, wet concrete) to the personal property of the community and Cherokee Nation Entertainment. Any impacts that affect personal property will need to be taken care of immediately to ensure there is no change in preconstruction appearance.
21. Construction personnel will be required to contact the CNE project manager when personal property is in the way of construction activities. Only in the case of life threatening situation should workers be permitted to handle or remove personal property.
22. Entry into adjacent occupied and unoccupied buildings is strictly prohibited unless otherwise determined by CNE project manager or property owner.
23. All construction team members should meet their responsibility to their fellow workmates and contractors by arriving on time fit for work.
24. Contractors should ensure that members of their team strictly adhere to break times and lunch periods allowed in their contract(s) and agreement(s).
25. Contractors maintain consistent productive work, keep idle time to a minimum, and make every

effort to eliminate unnecessary disruptions on the job that can cause delays in schedule. Slowdowns and delays of any kind utilized to extend jobs or produce overtime will not be tolerated.

26. Any outside activities that cast Cherokee Nation Entertainment, and/or affiliates in a negative light will not be tolerated and are grounds for dismissal.

27. Every effort shall be made by the contractor to make sure that proper safety equipment and methods are met every day they are on site.

28. NO ONE will be allowed to solicit funds on any CNE project or job without prior approval.

29. Personal calls are not to be made on any construction project site except for emergencies, during official lunch and break periods designated by the contractor.

30. Merchandise is not to be sold on or near the job site at any time.

31. Construction companies working for the Cherokee Nation Entertainment and affiliates shall ensure there are an appropriate number of employees on the job site to perform the work efficiently, economically, and safely.

The Code of Conduct is set in place to ensure a positive representation of Cherokee Nation Entertainment.

FOREMAN | MANHATTAN
Construction Team
Pre-Qualification

FOREMAN | MANHATTAN

Construction Team

In an effort to expedite and complete Foreman Manhattan Construction Team's Subcontractor Pre-Qualification process, please have these documents (attached) filled out by an officer of your Company and return all copies to my attention as soon as possible.

- The Subcontractor Pre-qualification Form (Form 2) - a document that you and your company will fill out regarding additional information about your company.
- Audited Financial Statement prepared by an outside accounting firm – we understand this is a highly sensitive and confidential document. This document is going directly to our Risk Manager. Your financial statement will be kept in a locked file cabinet in the Risk Management Department and the Risk Manager is the only person that sees it. Should you have any questions or concerns or want to mail/e-mail your financial statements please send to the following marked "Confidential":
 - Risk Management Department
Manhattan Construction Company
Beverly Hudson
Risk Manager
6300 North Central Expressway
Dallas, TX 75206
bhudson@manhattanconstruction.com
214-357-7400 Phone
- Surety Confirmation Letter with Power of Attorney Attached (Sample Attached). This letter is for your surety company to provide, basically saying that you are not a risk to Foreman Manhattan Construction Team.
- Current Certificate of Insurance (Form 3) (Example Attached).
- Form W-9 (Blank Form Attached).

The attached documents must be completed and on file prior to Foreman Manhattan issuing your contract documents.

The **GOOD NEWS** is that this will only be done approximately 16 months after the date of your last financial package at which time you will need to re-qualify. This will be based on whether you qualify to work on more than one project at a time and that you provide all required documentation. If your firm and insurance broker/agent are willing to issue to Foreman Manhattan the "Global" insurance certificate that is good for all work for Foreman Manhattan that too will only be requested upon policy expiration dates. Otherwise, the obvious exception is that specific insurance certificates will need to be issued for each job. All submissions should be made to our contract administrator, JLAllen@manhattanconstruction.com's attention with exception of the Financial Statement which will be sent to our Risk Manager as listed above.

Manhattan Construction Company
5601 South 122nd East Avenue
Tulsa, OK 74146
E-mail address: JLAllen@manhattanconstruction.com
918-583-6900 or 918-878-3304

Please fill these forms out and return as soon as possible. Should you have any questions please let me know and thank you for your cooperation."

Subcontractor Prequalification Form

Designate the Manhattan Division your firm works for (mark all that apply)

- Atlanta, GA Dallas, TX Houston, TX International Oklahoma City, OK Tulsa, OK
 Washington, DC Naples, FL Tampa, FL

SCOPE OF WORK:

In order to be pre-qualified this form must be completed with the following information attached:

- A copy of your latest audited financial statement prepared by an outside accounting firm. – Financials may be submitted separately via e-mail to Analyst Julie Stevens jstevens@manhattanconstruction.com, Risk Manager bhudson@manhattanconstruction.com or mailed to Manhattan Construction c/o Julie Stevens, 6300 North Central Expressway, Dallas, TX 75206. Please mark envelope as confidential. Please note date financials were submitted.
- A letter from your surety detailing the single project & aggregate amounts they are willing to issue on your behalf along with a power of attorney.
- A Copy of your current Certificate of Insurance (see example attached) meeting Manhattan's minimum Insurance requirements

COMPANY INFORMATION

Legal Name of Firm:		List any DBA's:	
Address:			
Phone #:	Fax #:	Contact:	Email:
Type of Company:	<input type="checkbox"/> Corporation <input type="checkbox"/> Partnership <input type="checkbox"/> Sole Proprietor <input type="checkbox"/> Other	Federal Tax ID #	
Years in Business under present name:		Ownership of Firm & Percentages:	
Is Firm currently rated with Dun & Bradstreet:		If Yes, what is your D&B rating & Number:	
<input type="checkbox"/> Yes <input type="checkbox"/> No			
Average work in place (last 5 years):		Work under contract:	
Average project size in place last year:		Uncompleted backlog:	
Current Number of Employees:	In Office:	In the Field:	
List all litigation against your firm in the past 5 years (use separate sheet if necessary):			
List all insurance claims over \$100,000 in the past 5 years (attach insurance company loss runs):			

BONDING, INSURANCE AND SAFETY INFORMATION

Is Subcontractor able to provide bid, payment and performance bonds?		<input type="checkbox"/> Yes <input type="checkbox"/> No	Bond Rate:	
Bonding Company	A.M. Best Rating:		Treasury Listed:	<input type="checkbox"/> Yes <input type="checkbox"/> No
Bonding Agency:	Contact Name:		Phone Number:	
Value of Work Presently Bonded:		Total Bonding Capacity:		
Insurance Agency Name:	Address:			
Insurance Contact Name:	Phone #:			
General Liability Limits:	per Occurrence	Aggregate		
Auto Liability Limits:	Combined Single Limit			
WC/Employers Liability:	/ / /			
Umbrella Liability:	per Occurrence	Aggregate		
Does your firm use any Employee Leasing Companies?		<input type="checkbox"/> Yes <input type="checkbox"/> No		
Can your General Liability, Auto and Umbrella policies name General Contractor and Owner as Additional Insured?			<input type="checkbox"/> Yes <input type="checkbox"/> No	
Can your GL, WC and Umbrella policies give Waiver of Subrogation to Contractor and Owner?			<input type="checkbox"/> Yes <input type="checkbox"/> No	
List WC Experience Modifier for past three policy years:	1 st Prior Year:	2 nd Prior Year:	3 rd Prior Year:	
Does your company have a written safety program and/or policy in place?	<input type="checkbox"/> Yes <input type="checkbox"/> No			
Does your company have a written drug policy?	<input type="checkbox"/> Yes <input type="checkbox"/> No			
Does your company employ a full-time site safety professional?	<input type="checkbox"/> Yes <input type="checkbox"/> No			

LIST FINANCIAL INFORMATION FOR LAST 3 FISCAL YEARS

Year	Annual Sales	Largest Single Contract Value

COMPLETED PROJECTS: LIST LAST 6 PROJECTS COMPLETED

Name of Project	Contracting Company	Contact Name/Phone	Contract Amt.	Completion Date	Bonded (Y/N)

CURRENT PROJECTS: LIST ALL PROJECTS UNDER CONSTRUCTION (USE A SEPARATE PAGE IF NECESSARY)

Name of Project	Contracting Company	Contact Name/Phone	Contract Amt.	Completion Date	Bonded (Y/N)

Subcontractor Prequalification Form Part II

CSI Trades

Major Trade Description:	
Territories/Geographic Area of Operations:	

DWMBE Classifications

<input type="checkbox"/> Minority (MBE)	<input type="checkbox"/> Women (WBE)	<input type="checkbox"/> Disadvantaged (DBE)	<input type="checkbox"/> Veterans	<input type="checkbox"/> Small Business	<input type="checkbox"/> Other:
Certification Agency:			Certification #:		
Certification Agency:			Certification #:		
Certification Agency:			Certification #:		

Type of Company:

<input type="checkbox"/> Subcontractor	<input type="checkbox"/> Supplier	<input type="checkbox"/> Manufacturers Rep	<input type="checkbox"/> Manufacturer	<input type="checkbox"/> Services
--	-----------------------------------	--	---------------------------------------	-----------------------------------

Type of Work

<input type="checkbox"/> Corporate, Office Buildings	<input type="checkbox"/> Institutional	<input type="checkbox"/> Hospitality	<input type="checkbox"/> Hospitals/Healthcare	<input type="checkbox"/> Public Assembly
<input type="checkbox"/> Correctional/Justice	<input type="checkbox"/> Mercantile	<input type="checkbox"/> Industrial	<input type="checkbox"/> Transportation	<input type="checkbox"/> Residential
<input type="checkbox"/> High Tech/Laboratories	<input type="checkbox"/> Infrastructure	<input type="checkbox"/> Design Build/Design Assist		

Select Min Contract Size

<input type="checkbox"/> No Min.	<input type="checkbox"/> \$250,000	<input type="checkbox"/> \$500,000	<input type="checkbox"/> \$1,000,000	<input type="checkbox"/> \$2,500,000	<input type="checkbox"/> \$5,000,000	<input type="checkbox"/> \$10,000,000	<input type="checkbox"/> >\$10,000,000
----------------------------------	------------------------------------	------------------------------------	--------------------------------------	--------------------------------------	--------------------------------------	---------------------------------------	--

Select Max Job Size

<input type="checkbox"/> \$500,000	<input type="checkbox"/> \$1,000,000	<input type="checkbox"/> \$5,000,000	<input type="checkbox"/> \$10,000,000	<input type="checkbox"/> \$15,000,000	<input type="checkbox"/> \$25,000,000	<input type="checkbox"/> \$50,000,000	<input type="checkbox"/> >\$50,000,000
------------------------------------	--------------------------------------	--------------------------------------	---------------------------------------	---------------------------------------	---------------------------------------	---------------------------------------	--

Select Type of Labor

<input type="checkbox"/> Union Shop	<input type="checkbox"/> Open Shop	<input type="checkbox"/> Prevailing Wages	<input type="checkbox"/> Open and/or Union Shop	<input type="checkbox"/> Open and/or Prevailing Wages
-------------------------------------	------------------------------------	---	---	---

% of Self Performed Work:	
Training Program:	
Avg. Annual Training Hours/Empl:	
ISO Certification:	
Certification:	

Select Licenses

Issuing Authority:	License Number:	Expiration:	
Issuing Authority:	License Number:	Expiration:	
Other License(s):			

Bank References

Company	Contact	Title	Phone	Fax	Email

CM/GC References

Company	Contact	Title	Phone	Fax	Email

Major Supplier References

Company	Contact	Title	Phone	Fax	Email

Client References

Company	Contact	Title	Phone	Fax	Email

List three most RECENT projects with Manhattan Construction Company

Job Name	MCC PM	Your PM/Supt	\$ Amount	Completion Date

Environmental Information

Check if they Apply

- Have an Environmental Statement and/or policy?
- Have a Waste Reduction and Recycling Program?
- Educate employees and vendors about this Program?
- Participate in the salvage and/or reuse of Waste Materials?
- Have you ever worked on a LEED Certified Project?

If so, please provide information on types:

Utilize recycled content construction materials?

If so, please provide information on types:

OTHER INFORMATION

Operated Under any other name?
(If yes, please Explain)

Yes/No:

Had Previous Ownership?
(If yes, please Explain)

Yes/No:

Had any liens filed against it by any of its Subcontractors or Suppliers?
(If yes, please Explain)

Yes/No:

Ever Defaulted on a contract?
(If yes, please Explain)

Yes/No:

Ever fail to complete a contract?
(If yes, please Explain)

Yes/No:

Ever been terminated?
(If yes, please Explain)

Yes/No:

Gone through a bankruptcy
or reorganization?
(If yes, please Explain)

Yes/No:

Had any principals in litigation?
(If yes, please Explain)

Yes/No:

Any labor law violations?
(If yes, please Explain)

Yes/No:

Is firm in Compliance with EEOC Requirement?
(If no, please Explain)

Yes/No:

Is firm in Compliance with U.S. Citizenship
& Immigration Services requirements?

Yes/No:

Been found to have committed a serious OSHA violation?
(If yes, please Explain)

Yes/No:

Committed a violation of State, Federal, or Local Laws?
(If yes, please Explain)

Yes/No:

Been declared ineligible to bid on or be awarded a Public Works contract,
or perform as a subcontractor on a Public Works Contract?
(Pursuant to Labor Code 1777.1 or 1777.7)
(If yes, please Explain)

Yes/No:

Been required to pay either back wages or penalties for failure to
comply with State or Federal Prevailing Wage Laws?
(If yes, please Explain)

Yes/No:

Had an apprenticeship Program in place for the past five years?
(If yes, please Explain)

Yes/No:

I hereby certify that the information herein is true and complete to the best of my knowledge:

Completed by: _____ Title: _____ Date: _____

Completed Form and supporting documentation must be submitted to: jlallen@manhattanconstruction.com

SAMPLE SURETY COMMITMENT LETTER

<Date>

Foreman Manhattan Construction Team
5601 South 122nd East Avenue
Tulsa, OK 74146

RE: <Subcontractor Name>

Since <Date Surety Relationship began>, <Name of Subcontractor's Agent> and the <Name of the Surety Company> have had the continuing privilege of providing surety bonds for <Subcontractor Name>. <Subcontractor Name> has a bonding capacity on individual projects of \$<individual project bonding capacity> and a total program capacity of \$<total program capacity>.

The estimated cost of the Performance and Payment Bond will be charged at a rate of \$<Rate> per \$1000 of contract work.

In our opinion, <Subcontractor Name> is one of the finest, best managed construction firms in the country. <Subcontractor Name> has handled each of its projects in a professional manner and completed all work satisfactorily.

We hope the above demonstrates our utmost confidence in <Subcontractor Name>. We anticipate no problems in providing the necessary Performance and Payment bonds for the above referenced project.

Should you have any questions, please do not hesitate to call.

Sincerely,

<Agent Name and Notarized Signature>

****PLEASE INCLUDE AGENT'S POWER OF ATTORNEY****

Request for Taxpayer Identification Number and Certification

**Give Form to the
 requester. Do not
 send to the IRS.**

Print or type See Specific Instructions on page 2.	Name (as shown on your income tax return)	
	Business name/disregarded entity name, if different from above	
	Check appropriate box for federal tax classification: <input type="checkbox"/> Individual/sole proprietor <input type="checkbox"/> C Corporation <input type="checkbox"/> S Corporation <input type="checkbox"/> Partnership <input type="checkbox"/> Trust/estate <input type="checkbox"/> Limited liability company. Enter the tax classification (C=C corporation, S=S corporation, P=partnership) ▶ _____ <input type="checkbox"/> Other (see instructions) ▶ _____	Exemptions (see instructions): Exempt payee code (if any) _____ Exemption from FATCA reporting code (if any) _____
	Address (number, street, and apt. or suite no.)	Requester's name and address (optional)
	City, state, and ZIP code	
List account number(s) here (optional)		

Part I Taxpayer Identification Number (TIN)

Enter your TIN in the appropriate box. The TIN provided must match the name given on the "Name" line to avoid backup withholding. For individuals, this is your social security number (SSN). However, for a resident alien, sole proprietor, or disregarded entity, see the Part I instructions on page 3. For other entities, it is your employer identification number (EIN). If you do not have a number, see *How to get a TIN* on page 3.

Social security number									

Note. If the account is in more than one name, see the chart on page 4 for guidelines on whose number to enter.

Employer identification number									

Part II Certification

Under penalties of perjury, I certify that:

1. The number shown on this form is my correct taxpayer identification number (or I am waiting for a number to be issued to me), and
2. I am not subject to backup withholding because: (a) I am exempt from backup withholding, or (b) I have not been notified by the Internal Revenue Service (IRS) that I am subject to backup withholding as a result of a failure to report all interest or dividends, or (c) the IRS has notified me that I am no longer subject to backup withholding, and
3. I am a U.S. citizen or other U.S. person (defined below), and
4. The FATCA code(s) entered on this form (if any) indicating that I am exempt from FATCA reporting is correct.

Certification instructions. You must cross out item 2 above if you have been notified by the IRS that you are currently subject to backup withholding because you have failed to report all interest and dividends on your tax return. For real estate transactions, item 2 does not apply. For mortgage interest paid, acquisition or abandonment of secured property, cancellation of debt, contributions to an individual retirement arrangement (IRA), and generally, payments other than interest and dividends, you are not required to sign the certification, but you must provide your correct TIN. See the instructions on page 3.

Sign Here	Signature of U.S. person ▶	Date ▶
------------------	----------------------------	--------

General Instructions

Section references are to the Internal Revenue Code unless otherwise noted.

Future developments. The IRS has created a page on IRS.gov for information about Form W-9, at www.irs.gov/w9. Information about any future developments affecting Form W-9 (such as legislation enacted after we release it) will be posted on that page.

Purpose of Form

A person who is required to file an information return with the IRS must obtain your correct taxpayer identification number (TIN) to report, for example, income paid to you, payments made to you in settlement of payment card and third party network transactions, real estate transactions, mortgage interest you paid, acquisition or abandonment of secured property, cancellation of debt, or contributions you made to an IRA.

Use Form W-9 only if you are a U.S. person (including a resident alien), to provide your correct TIN to the person requesting it (the requester) and, when applicable, to:

1. Certify that the TIN you are giving is correct (or you are waiting for a number to be issued),
2. Certify that you are not subject to backup withholding, or
3. Claim exemption from backup withholding if you are a U.S. exempt payee. If applicable, you are also certifying that as a U.S. person, your allocable share of any partnership income from a U.S. trade or business is not subject to the

withholding tax on foreign partners' share of effectively connected income, and

4. Certify that FATCA code(s) entered on this form (if any) indicating that you are exempt from the FATCA reporting, is correct.

Note. If you are a U.S. person and a requester gives you a form other than Form W-9 to request your TIN, you must use the requester's form if it is substantially similar to this Form W-9.

Definition of a U.S. person. For federal tax purposes, you are considered a U.S. person if you are:

- An individual who is a U.S. citizen or U.S. resident alien,
- A partnership, corporation, company, or association created or organized in the United States or under the laws of the United States,
- An estate (other than a foreign estate), or
- A domestic trust (as defined in Regulations section 301.7701-7).

Special rules for partnerships. Partnerships that conduct a trade or business in the United States are generally required to pay a withholding tax under section 1446 on any foreign partners' share of effectively connected taxable income from such business. Further, in certain cases where a Form W-9 has not been received, the rules under section 1446 require a partnership to presume that a partner is a foreign person, and pay the section 1446 withholding tax. Therefore, if you are a U.S. person that is a partner in a partnership conducting a trade or business in the United States, provide Form W-9 to the partnership to establish your U.S. status and avoid section 1446 withholding on your share of partnership income.

In the cases below, the following person must give Form W-9 to the partnership for purposes of establishing its U.S. status and avoiding withholding on its allocable share of net income from the partnership conducting a trade or business in the United States:

- In the case of a disregarded entity with a U.S. owner, the U.S. owner of the disregarded entity and not the entity,
- In the case of a grantor trust with a U.S. grantor or other U.S. owner, generally, the U.S. grantor or other U.S. owner of the grantor trust and not the trust, and
- In the case of a U.S. trust (other than a grantor trust), the U.S. trust (other than a grantor trust) and not the beneficiaries of the trust.

Foreign person. If you are a foreign person or the U.S. branch of a foreign bank that has elected to be treated as a U.S. person, do not use Form W-9. Instead, use the appropriate Form W-8 or Form 8233 (see Publication 515, Withholding of Tax on Nonresident Aliens and Foreign Entities).

Nonresident alien who becomes a resident alien. Generally, only a nonresident alien individual may use the terms of a tax treaty to reduce or eliminate U.S. tax on certain types of income. However, most tax treaties contain a provision known as a "saving clause." Exceptions specified in the saving clause may permit an exemption from tax to continue for certain types of income even after the payee has otherwise become a U.S. resident alien for tax purposes.

If you are a U.S. resident alien who is relying on an exception contained in the saving clause of a tax treaty to claim an exemption from U.S. tax on certain types of income, you must attach a statement to Form W-9 that specifies the following five items:

1. The treaty country. Generally, this must be the same treaty under which you claimed exemption from tax as a nonresident alien.
2. The treaty article addressing the income.
3. The article number (or location) in the tax treaty that contains the saving clause and its exceptions.
4. The type and amount of income that qualifies for the exemption from tax.
5. Sufficient facts to justify the exemption from tax under the terms of the treaty article.

Example. Article 20 of the U.S.-China income tax treaty allows an exemption from tax for scholarship income received by a Chinese student temporarily present in the United States. Under U.S. law, this student will become a resident alien for tax purposes if his or her stay in the United States exceeds 5 calendar years. However, paragraph 2 of the first Protocol to the U.S.-China treaty (dated April 30, 1984) allows the provisions of Article 20 to continue to apply even after the Chinese student becomes a resident alien of the United States. A Chinese student who qualifies for this exception (under paragraph 2 of the first protocol) and is relying on this exception to claim an exemption from tax on his or her scholarship or fellowship income would attach to Form W-9 a statement that includes the information described above to support that exemption.

If you are a nonresident alien or a foreign entity, give the requester the appropriate completed Form W-8 or Form 8233.

What is backup withholding? Persons making certain payments to you must under certain conditions withhold and pay to the IRS a percentage of such payments. This is called "backup withholding." Payments that may be subject to backup withholding include interest, tax-exempt interest, dividends, broker and barter exchange transactions, rents, royalties, nonemployee pay, payments made in settlement of payment card and third party network transactions, and certain payments from fishing boat operators. Real estate transactions are not subject to backup withholding.

You will not be subject to backup withholding on payments you receive if you give the requester your correct TIN, make the proper certifications, and report all your taxable interest and dividends on your tax return.

Payments you receive will be subject to backup withholding if:

1. You do not furnish your TIN to the requester,
2. You do not certify your TIN when required (see the Part II instructions on page 3 for details),
3. The IRS tells the requester that you furnished an incorrect TIN,
4. The IRS tells you that you are subject to backup withholding because you did not report all your interest and dividends on your tax return (for reportable interest and dividends only), or
5. You do not certify to the requester that you are not subject to backup withholding under 4 above (for reportable interest and dividend accounts opened after 1983 only).

Certain payees and payments are exempt from backup withholding. See *Exempt payee code* on page 3 and the separate Instructions for the Requester of Form W-9 for more information.

Also see *Special rules for partnerships* on page 1.

What is FATCA reporting? The Foreign Account Tax Compliance Act (FATCA) requires a participating foreign financial institution to report all United States account holders that are specified United States persons. Certain payees are exempt from FATCA reporting. See *Exemption from FATCA reporting code* on page 3 and the Instructions for the Requester of Form W-9 for more information.

Updating Your Information

You must provide updated information to any person to whom you claimed to be an exempt payee if you are no longer an exempt payee and anticipate receiving reportable payments in the future from this person. For example, you may need to provide updated information if you are a C corporation that elects to be an S corporation, or if you no longer are tax exempt. In addition, you must furnish a new Form W-9 if the name or TIN changes for the account, for example, if the grantor of a grantor trust dies.

Penalties

Failure to furnish TIN. If you fail to furnish your correct TIN to a requester, you are subject to a penalty of \$50 for each such failure unless your failure is due to reasonable cause and not to willful neglect.

Civil penalty for false information with respect to withholding. If you make a false statement with no reasonable basis that results in no backup withholding, you are subject to a \$500 penalty.

Criminal penalty for falsifying information. Willfully falsifying certifications or affirmations may subject you to criminal penalties including fines and/or imprisonment.

Misuse of TINs. If the requester discloses or uses TINs in violation of federal law, the requester may be subject to civil and criminal penalties.

Specific Instructions

Name

If you are an individual, you must generally enter the name shown on your income tax return. However, if you have changed your last name, for instance, due to marriage without informing the Social Security Administration of the name change, enter your first name, the last name shown on your social security card, and your new last name.

If the account is in joint names, list first, and then circle, the name of the person or entity whose number you entered in Part I of the form.

Sole proprietor. Enter your individual name as shown on your income tax return on the "Name" line. You may enter your business, trade, or "doing business as (DBA)" name on the "Business name/disregarded entity name" line.

Partnership, C Corporation, or S Corporation. Enter the entity's name on the "Name" line and any business, trade, or "doing business as (DBA) name" on the "Business name/disregarded entity name" line.

Disregarded entity. For U.S. federal tax purposes, an entity that is disregarded as an entity separate from its owner is treated as a "disregarded entity." See Regulation section 301.7701-2(c)(2)(iii). Enter the owner's name on the "Name" line. The name of the entity entered on the "Name" line should never be a disregarded entity. The name on the "Name" line must be the name shown on the income tax return on which the income should be reported. For example, if a foreign LLC that is treated as a disregarded entity for U.S. federal tax purposes has a single owner that is a U.S. person, the U.S. owner's name is required to be provided on the "Name" line. If the direct owner of the entity is also a disregarded entity, enter the first owner that is not disregarded for federal tax purposes. Enter the disregarded entity's name on the "Business name/disregarded entity name" line. If the owner of the disregarded entity is a foreign person, the owner must complete an appropriate Form W-8 instead of a Form W-9. This is the case even if the foreign person has a U.S. TIN.

Note. Check the appropriate box for the U.S. federal tax classification of the person whose name is entered on the "Name" line (Individual/sole proprietor, Partnership, C Corporation, S Corporation, Trust/estate).

Limited Liability Company (LLC). If the person identified on the "Name" line is an LLC, check the "Limited liability company" box only and enter the appropriate code for the U.S. federal tax classification in the space provided. If you are an LLC that is treated as a partnership for U.S. federal tax purposes, enter "P" for partnership. If you are an LLC that has filed a Form 8832 or a Form 2553 to be taxed as a corporation, enter "C" for C corporation or "S" for S corporation, as appropriate. If you are an LLC that is disregarded as an entity separate from its owner under Regulation section 301.7701-3 (except for employment and excise tax), do not check the LLC box unless the owner of the LLC (required to be identified on the "Name" line) is another LLC that is not disregarded for U.S. federal tax purposes. If the LLC is disregarded as an entity separate from its owner, enter the appropriate tax classification of the owner identified on the "Name" line.

Other entities. Enter your business name as shown on required U.S. federal tax documents on the "Name" line. This name should match the name shown on the charter or other legal document creating the entity. You may enter any business, trade, or DBA name on the "Business name/disregarded entity name" line.

Exemptions

If you are exempt from backup withholding and/or FATCA reporting, enter in the *Exemptions* box, any code(s) that may apply to you. See *Exempt payee code* and *Exemption from FATCA reporting code* on page 3.

Exempt payee code. Generally, individuals (including sole proprietors) are not exempt from backup withholding. Corporations are exempt from backup withholding for certain payments, such as interest and dividends. Corporations are not exempt from backup withholding for payments made in settlement of payment card or third party network transactions.

Note. If you are exempt from backup withholding, you should still complete this form to avoid possible erroneous backup withholding.

The following codes identify payees that are exempt from backup withholding:

- 1—An organization exempt from tax under section 501(a), any IRA, or a custodial account under section 403(b)(7) if the account satisfies the requirements of section 401(f)(2)
- 2—The United States or any of its agencies or instrumentalities
- 3—A state, the District of Columbia, a possession of the United States, or any of their political subdivisions or instrumentalities
- 4—A foreign government or any of its political subdivisions, agencies, or instrumentalities
- 5—A corporation
- 6—A dealer in securities or commodities required to register in the United States, the District of Columbia, or a possession of the United States
- 7—A futures commission merchant registered with the Commodity Futures Trading Commission
- 8—A real estate investment trust
- 9—An entity registered at all times during the tax year under the Investment Company Act of 1940
- 10—A common trust fund operated by a bank under section 584(a)
- 11—A financial institution
- 12—A middleman known in the investment community as a nominee or custodian
- 13—A trust exempt from tax under section 664 or described in section 4947

The following chart shows types of payments that may be exempt from backup withholding. The chart applies to the exempt payees listed above, 1 through 13.

IF the payment is for . . .	THEN the payment is exempt for . . .
Interest and dividend payments	All exempt payees except for 7
Broker transactions	Exempt payees 1 through 4 and 6 through 11 and all C corporations. S corporations must not enter an exempt payee code because they are exempt only for sales of noncovered securities acquired prior to 2012.
Barter exchange transactions and patronage dividends	Exempt payees 1 through 4
Payments over \$600 required to be reported and direct sales over \$5,000 ¹	Generally, exempt payees 1 through 5 ²
Payments made in settlement of payment card or third party network transactions	Exempt payees 1 through 4

¹ See Form 1099-MISC, Miscellaneous Income, and its instructions.

² However, the following payments made to a corporation and reportable on Form 1099-MISC are not exempt from backup withholding: medical and health care payments, attorneys' fees, gross proceeds paid to an attorney, and payments for services paid by a federal executive agency.

Exemption from FATCA reporting code. The following codes identify payees that are exempt from reporting under FATCA. These codes apply to persons submitting this form for accounts maintained outside of the United States by certain foreign financial institutions. Therefore, if you are only submitting this form for an account you hold in the United States, you may leave this field blank. Consult with the person requesting this form if you are uncertain if the financial institution is subject to these requirements.

- A—An organization exempt from tax under section 501(a) or any individual retirement plan as defined in section 7701(a)(37)
- B—The United States or any of its agencies or instrumentalities
- C—A state, the District of Columbia, a possession of the United States, or any of their political subdivisions or instrumentalities
- D—A corporation the stock of which is regularly traded on one or more established securities markets, as described in Reg. section 1.1472-1(c)(1)(i)
- E—A corporation that is a member of the same expanded affiliated group as a corporation described in Reg. section 1.1472-1(c)(1)(i)
- F—A dealer in securities, commodities, or derivative financial instruments (including notional principal contracts, futures, forwards, and options) that is registered as such under the laws of the United States or any state

- G—A real estate investment trust
- H—A regulated investment company as defined in section 851 or an entity registered at all times during the tax year under the Investment Company Act of 1940
- I—A common trust fund as defined in section 584(a)
- J—A bank as defined in section 581
- K—A broker
- L—A trust exempt from tax under section 664 or described in section 4947(a)(1)
- M—A tax exempt trust under a section 403(b) plan or section 457(g) plan

Part I. Taxpayer Identification Number (TIN)

Enter your TIN in the appropriate box. If you are a resident alien and you do not have and are not eligible to get an SSN, your TIN is your IRS individual taxpayer identification number (ITIN). Enter it in the social security number box. If you do not have an ITIN, see *How to get a TIN* below.

If you are a sole proprietor and you have an EIN, you may enter either your SSN or EIN. However, the IRS prefers that you use your SSN.

If you are a single-member LLC that is disregarded as an entity separate from its owner (see *Limited Liability Company (LLC)* on page 2), enter the owner's SSN (or EIN, if the owner has one). Do not enter the disregarded entity's EIN. If the LLC is classified as a corporation or partnership, enter the entity's EIN.

Note. See the chart on page 4 for further clarification of name and TIN combinations.

How to get a TIN. If you do not have a TIN, apply for one immediately. To apply for an SSN, get Form SS-5, Application for a Social Security Card, from your local Social Security Administration office or get this form online at www.ssa.gov. You may also get this form by calling 1-800-772-1213. Use Form W-7, Application for IRS Individual Taxpayer Identification Number, to apply for an ITIN, or Form SS-4, Application for Employer Identification Number, to apply for an EIN. You can apply for an EIN online by accessing the IRS website at www.irs.gov/businesses and clicking on Employer Identification Number (EIN) under Starting a Business. You can get Forms W-7 and SS-4 from the IRS by visiting IRS.gov or by calling 1-800-TAX-FORM (1-800-829-3676).

If you are asked to complete Form W-9 but do not have a TIN, apply for a TIN and write "Applied For" in the space for the TIN, sign and date the form, and give it to the requester. For interest and dividend payments, and certain payments made with respect to readily tradable instruments, generally you will have 60 days to get a TIN and give it to the requester before you are subject to backup withholding on payments. The 60-day rule does not apply to other types of payments. You will be subject to backup withholding on all such payments until you provide your TIN to the requester.

Note. Entering "Applied For" means that you have already applied for a TIN or that you intend to apply for one soon.

Caution: A disregarded U.S. entity that has a foreign owner must use the appropriate Form W-8.

Part II. Certification

To establish to the withholding agent that you are a U.S. person, or resident alien, sign Form W-9. You may be requested to sign by the withholding agent even if items 1, 4, or 5 below indicate otherwise.

For a joint account, only the person whose TIN is shown in Part I should sign (when required). In the case of a disregarded entity, the person identified on the "Name" line must sign. Exempt payees, see *Exempt payee code* earlier.

Signature requirements. Complete the certification as indicated in items 1 through 5 below.

1. Interest, dividend, and barter exchange accounts opened before 1984 and broker accounts considered active during 1983. You must give your correct TIN, but you do not have to sign the certification.

2. Interest, dividend, broker, and barter exchange accounts opened after 1983 and broker accounts considered inactive during 1983. You must sign the certification or backup withholding will apply. If you are subject to backup withholding and you are merely providing your correct TIN to the requester, you must cross out item 2 in the certification before signing the form.

3. Real estate transactions. You must sign the certification. You may cross out item 2 of the certification.

4. Other payments. You must give your correct TIN, but you do not have to sign the certification unless you have been notified that you have previously given an incorrect TIN. "Other payments" include payments made in the course of the requester's trade or business for rents, royalties, goods (other than bills for merchandise), medical and health care services (including payments to corporations), payments to a nonemployee for services, payments made in settlement of payment card and third party network transactions, payments to certain fishing boat crew members and fishermen, and gross proceeds paid to attorneys (including payments to corporations).

5. Mortgage interest paid by you, acquisition or abandonment of secured property, cancellation of debt, qualified tuition program payments (under section 529), IRA, Coverdell ESA, Archer MSA or HSA contributions or distributions, and pension distributions. You must give your correct TIN, but you do not have to sign the certification.

What Name and Number To Give the Requester

For this type of account:	Give name and SSN of:
1. Individual	The individual
2. Two or more individuals (joint account)	The actual owner of the account or, if combined funds, the first individual on the account ¹
3. Custodian account of a minor (Uniform Gift to Minors Act)	The minor ²
4. a. The usual revocable savings trust (grantor is also trustee)	The grantor-trustee ¹
b. So-called trust account that is not a legal or valid trust under state law	The actual owner ¹
5. Sole proprietorship or disregarded entity owned by an individual	The owner ³
6. Grantor trust filing under Optional Form 1099 Filing Method 1 (see Regulation section 1.671-4(b)(2)(i)(A))	The grantor*
For this type of account:	Give name and EIN of:
7. Disregarded entity not owned by an individual	The owner
8. A valid trust, estate, or pension trust	Legal entity ⁴
9. Corporation or LLC electing corporate status on Form 8832 or Form 2553	The corporation
10. Association, club, religious, charitable, educational, or other tax-exempt organization	The organization
11. Partnership or multi-member LLC	The partnership
12. A broker or registered nominee	The broker or nominee
13. Account with the Department of Agriculture in the name of a public entity (such as a state or local government, school district, or prison) that receives agricultural program payments	The public entity
14. Grantor trust filing under the Form 1041 Filing Method or the Optional Form 1099 Filing Method 2 (see Regulation section 1.671-4(b)(2)(i)(B))	The trust

¹ List first and circle the name of the person whose number you furnish. If only one person on a joint account has an SSN, that person's number must be furnished.

² Circle the minor's name and furnish the minor's SSN.

³ You must show your individual name and you may also enter your business or "DBA" name on the "Business name/disregarded entity" name line. You may use either your SSN or EIN (if you have one), but the IRS encourages you to use your SSN.

⁴ List first and circle the name of the trust, estate, or pension trust. (Do not furnish the TIN of the personal representative or trustee unless the legal entity itself is not designated in the account title.) Also see *Special rules for partnerships* on page 1.

*Note. Grantor also must provide a Form W-9 to trustee of trust.

Note. If no name is circled when more than one name is listed, the number will be considered to be that of the first name listed.

Secure Your Tax Records from Identity Theft

Identity theft occurs when someone uses your personal information such as your name, social security number (SSN), or other identifying information, without your permission, to commit fraud or other crimes. An identity thief may use your SSN to get a job or may file a tax return using your SSN to receive a refund.

To reduce your risk:

- Protect your SSN,
- Ensure your employer is protecting your SSN, and
- Be careful when choosing a tax preparer.

If your tax records are affected by identity theft and you receive a notice from the IRS, respond right away to the name and phone number printed on the IRS notice or letter.

If your tax records are not currently affected by identity theft but you think you are at risk due to a lost or stolen purse or wallet, questionable credit card activity or credit report, contact the IRS Identity Theft Hotline at 1-800-908-4490 or submit Form 14039.

For more information, see Publication 4535, Identity Theft Prevention and Victim Assistance.

Victims of identity theft who are experiencing economic harm or a system problem, or are seeking help in resolving tax problems that have not been resolved through normal channels, may be eligible for Taxpayer Advocate Service (TAS) assistance. You can reach TAS by calling the TAS toll-free case intake line at 1-877-777-4778 or TTY/TDD 1-800-829-4059.

Protect yourself from suspicious emails or phishing schemes. Phishing is the creation and use of email and websites designed to mimic legitimate business emails and websites. The most common act is sending an email to a user falsely claiming to be an established legitimate enterprise in an attempt to scam the user into surrendering private information that will be used for identity theft.

The IRS does not initiate contacts with taxpayers via emails. Also, the IRS does not request personal detailed information through email or ask taxpayers for the PIN numbers, passwords, or similar secret access information for their credit card, bank, or other financial accounts.

If you receive an unsolicited email claiming to be from the IRS, forward this message to phishing@irs.gov. You may also report misuse of the IRS name, logo, or other IRS property to the Treasury Inspector General for Tax Administration at 1-800-366-4484. You can forward suspicious emails to the Federal Trade Commission at: spam@uce.gov or contact them at www.ftc.gov/idtheft or 1-877-IDTHEFT (1-877-438-4338).

Visit IRS.gov to learn more about identity theft and how to reduce your risk.

Privacy Act Notice

Section 6109 of the Internal Revenue Code requires you to provide your correct TIN to persons (including federal agencies) who are required to file information returns with the IRS to report interest, dividends, or certain other income paid to you; mortgage interest you paid; the acquisition or abandonment of secured property; the cancellation of debt; or contributions you made to an IRA, Archer MSA, or HSA. The person collecting this form uses the information on the form to file information returns with the IRS, reporting the above information. Routine uses of this information include giving it to the Department of Justice for civil and criminal litigation and to cities, states, the District of Columbia, and U.S. commonwealths and possessions for use in administering their laws. The information also may be disclosed to other countries under a treaty, to federal and state agencies to enforce civil and criminal laws, or to federal law enforcement and intelligence agencies to combat terrorism. You must provide your TIN whether or not you are required to file a tax return. Under section 3406, payers must generally withhold a percentage of taxable interest, dividend, and certain other payments to a payee who does not give a TIN to the payer. Certain penalties may also apply for providing false or fraudulent information.

Exhibit C

CERTIFICATE OF LIABILITY INSURANCE						ISSUE DATE (MM/DD/YY)
PRODUCER ****AGENTS PLEASE REVIEW SUBCONTRACTOR MGP INSURANCE RIDER FOR ALL CONTRACTUAL INSURANCE REQUIREMENTS****			THIS CERTIFICATE IS ISSUED AS A MATTER OF INFORMATION ONLY AND CONFERS NO RIGHTS UPON THE CERTIFICATE HOLDER. THIS CERTIFICATE DOES NOT AMEND, EXTEND OR ALTER THE COVERAGE AFFORDED BY THE POLICIES BELOW.			
PHONE NUMBER			INSURERS AFFORDING COVERAGE			
INSURED PHONE NUMBER			INSURER		LETTER A	
			INSURER		LETTER B	
			INSURER		LETTER C	
			INSURER		LETTER D	
			INSURER		LETTER E	
COVERAGES						
THIS IS TO CERTIFY THAT THE POLICIES OF INSURANCE LISTED BELOW HAVE BEEN ISSUED TO THE INSURED NAMED ABOVE FOR THE POLICY PERIOD INDICATED, NOTWITHSTANDING ANY REQUIREMENT, TERM OR CONDITION OF ANY CONTRACT OR OTHER DOCUMENT WITH RESPECT TO WHICH THIS CERTIFICATE MAY BE ISSUED OR MAY PERTAIN, THE INSURANCE AFFORDED BY THE POLICIES DESCRIBED HEREIN IS SUBJECT TO ALL TERMS, EXCLUSIONS AND CONDITIONS OF SUCH POLICIES. LIMITS SHOWN MAY HAVE BEEN REDUCED BY PAID CLAIMS.						
INSUR LTR	TYPE OF INSURANCE	POLICY NUMBER	POLICY EFFECTIVE DATE (MM/DD/YY)	POLICY EXPIRATION DATE (MM/DD/YY)	LIMITS	
	GENERAL LIABILITY <input checked="" type="checkbox"/> COMMERCIAL GENERAL LIABILITY <input type="checkbox"/> CLAIMS MADE <input checked="" type="checkbox"/> OCCUR. <input checked="" type="checkbox"/> Addl Insured Endt (CG2010 11 85 or <input checked="" type="checkbox"/> Waiver of Subrogation Endorsement POLICY <input type="checkbox"/> PROJECT <input checked="" type="checkbox"/> LOC <input type="checkbox"/>				EACH OCCURRENCE \$1,000,000 FIRE DAMAGE (Any one fire) \$50,000 MED EXP (Any one person) \$5,000 PERSONAL & ADV INJURY \$1,000,000 GENERAL AGGREGATE \$2,000,000 PRODUCTS-COMP/OP ACG \$2,000,000	
	AUTOMOBILE LIABILITY <input checked="" type="checkbox"/> ANY AUTO <input type="checkbox"/> ALL OWNED AUTOS <input type="checkbox"/> SCHEDULED AUTOS <input checked="" type="checkbox"/> HIRED AUTOS <input checked="" type="checkbox"/> NON-OWNED AUTOS <input type="checkbox"/> GARAGE LIABILITY <input checked="" type="checkbox"/> Additional Insured Endorsement <input checked="" type="checkbox"/> Waiver of Subrogation Endorsement				COMEBINED SINGLE LIMIT (Ea Accident) \$1,000,000 BODILY INJURY (Per person) \$ BODILY INJURY (Per Accident) \$ PROPERTY DAMAGE (Per Accident) \$	
	GARAGE LIABILITY <input type="checkbox"/> ANY AUTO				AUTO ONLY - EA ACCIDENT \$ OTHER THAN AUTO EA ACC \$ ONLY: AGG \$	
	EXCESS LIABILITY OR UMBRELLA POLICY <input checked="" type="checkbox"/> OCCUR <input type="checkbox"/> CLAIMS MADE <input type="checkbox"/> DEDUCTIBLE <input type="checkbox"/> RETENTION <input checked="" type="checkbox"/> Additional Insured <input checked="" type="checkbox"/> Waiver of Subrogation				EACH OCCURRENCE \$3,000,000 AGGREGATE \$3,000,000	
	WORKER'S COMPENSATION AND EMPLOYERS' LIABILITY <input checked="" type="checkbox"/> Waiver of Subrogation Endorsement				<input checked="" type="checkbox"/> WC STATUTORY LIMITS OT \$ E.L. EACH ACCIDENT \$1,000,000 E.L. DISEASE-POLICY LIMIT \$1,000,000 E.L. DISEASE-EACH EMPLOYEE \$1,000,000	
	OTHER PROFESSIONAL LIABILITY POLLUTION LIABILITY	(IF APPLICABLE BY CONTRACT)	WILL ALSO REQUIRE ADDITIONAL INSURED STATUS IN FAVOR OF MANHATTAN, OWNER & OTHERS ON POLLUTION POLICY IF APPLICABLE		\$2,000,000 \$2,000,000	
DESCRIPTION OF OPERATIONS/LOCATION/VEHICLES/SPECIAL ITEMS						
Certificate Applies to All Jobs for Manhattan Construction Company Additional Insured in favor of Manhattan Construction Company, Owner and others as required by written contract on GL, Auto & Umbrella Policies. Additional Insured Endorsements for Ongoing and Completed Operations are attached. Excess and/or Umbrella follows form. All policies, including excess or umbrella policies, are primary and non-contributory to any other insurance available to the Additional Insureds. Waiver of Subrogation in favor of Manhattan Construction Company, Owner and others as required by written contract on GL and WC Policies. Workers Compensation Coverage covers ALL employees of the insured in the state where work is being performed. General Liability and Excess/Umbrella Policies do not contain a residential exclusion						
CERTIFICATE HOLDER				CANCELLATION		
Manhattan Construction Company 6300 North Central Expressway Dallas, TX 75206 SEND EMAIL TO: INSURANCECERTS@MANHATTANCONSTRUCTION.COM				SHOULD ANY OF THE ABOVE DESCRIBED POLICIES BE CANCELLED BEFORE THE EXPIRA DATE THEREOF, THE ISSUING COMPANY WILL MAIL 30 DAYS WRITTEN NOTICE TO THE CERTIFICATE HOLDER NAMED TO THE LEFT.		
				AUTHORIZED REPRESENTATIVE		

BID PACKAGE – CNE Tahlequah Casino: SCOPE PACKAGE 10.01 – OPERABLE PARTITIONS

Submitted by (Company Name per W-9 Form): _____

Provide the following *Lump Sum Proposal* as requested in accordance with all scope items listed in Scope of Work.

BASE BID – OPERABLE PARTITIONS: \$ _____

Wall Covering for partition finished surfaces (partitions to arrive with Wall covering pre-installed) \$25 x _____ SY = \$ _____

TOTAL BASE BID, INCLUDING WALL COVERING: \$ _____

BID ALTERNATES:

Alternates shall be inclusive of all required labor, materials and equipment in accordance with all general scope items listed in the Exhibit "A" Scope of Work:

Alternate # 01 – Provide Alternate pricing for partition layout shown on the attached sketch as "ALT #1 LAYOUT"
This Alternate No. 1 is defined as a net change DEDUCT adjustment to the base bid amount.

Alternate No 1 - Wall Covering for partition finished surfaces (partitions to arrive with Wall covering pre-installed)
\$25 x _____ SY = \$ _____

Alternate No. 1 – NET CHANGEADD / DEDUCT \$ _____ / LS
(Total Alt No. 1 Price INCLUDES Wall Covering)

Other Comments:

Contact Name: _____

Address: _____

Phone/Fax: _____

Email: _____

Signature: _____

By acknowledging items below, bidder certifies acceptance of these documents and that all associated costs have been included in the proposal amount. Any and all exceptions/comments to these documents must be attached to this proposal. Comments or requested revisions to these documents will not be accepted after this proposal date.

TERO bidders must supply a copy of TERO Certificate, front of back

Initial:

Non-Collusion Affidavit

Initial:

Business Relationship Affidavit

Initial:

Acknowledge all scope of work items listed under scope of work (See Exhibit A)

Initial:

Acknowledge Exhibits B, C, D, E, F, G, H

Initial:

Addenda Included

#'s:

MCC Clarifications Included

#'s:

Acknowledge and agree to Foreman Manhattan Standard Subcontract Agreement/Special Terms and Conditions as per Exhibit E

Initial:

Acknowledge and agree to Manhattan General Provisions as Included in the Bid Documents

Initial:

SCHEDULE/EXPEDITING/SUBMITTALS

Foreman Manhattan Construction Target Schedule is attached. Please verify supplier is able to meet Foreman Manhattan required installation dates.

Initial:

Sales Tax

All bids must be submitted exclusive of Federal Excise Tax and Oklahoma State Sales Tax. The Cherokee Nation is exempt from Oklahoma State Sales Tax and Federal Excise Tax under authority of § Okla. Stat. Supp. 1994 Section 1356. Bidder is to include and pay all other applicable sales tax and use taxes as required. Applications for payment shall be broken down as required by the Owner or Construction Manager.

Specific Project Requirements for the process, approval, and payment of Owner-Direct Payment Items (ODPI) are identified in section 00 60 09:

EXHIBIT “G” Tax Exempt / Owner Direct Paid Invoice (ODPI) Payment Process

Tribal Employment Rights Office.

SUBCONTRACTOR IS TO COMPLY WITH ALL CHEROKEE NATION, TRIBAL EMPLOYMENT RIGHTS OFFICE (TERO), NATIONAL INDIAN GAMING ASSOCIATION (NIGA), AND ALL BUREAU OF INDIAN AFFAIRS (BIA) RULES, REGULATIONS, AND LICENSING REQUIREMENTS INCLUDING ALL FEES AND ASSESSMENTS, ASSESSMENT, APPLICABLE TO THIS PROJECT.

11.1.1 - TERO document “An Act” Legislative Act 01-14 dated February 10, 2014.
This Document is ACT AMENDING LA 30-12, "CHEROKEE NATION EMPLOYMENT RIGHTS ACT"

11.1.2 - Subcontractors are to EXCLUDE the cost for Section; Title 40, § 1011; T.
To assess an Employee Rights Fee of one-half (1/2) of one percent (1%) on all covered contracts. This cost will be paid by the Construction Manager.

11.1.3 - The Work Permits paragraph of the Tribal Employment Rights Office (TERO) Project Labor Agreement - Master Agreement LA 01-14 states: No person who is not a member of a federally recognized tribe shall be employed by a covered employer until he or she has obtained a work permit from the TERO at a cost of twenty-five dollars (\$25) per day, per permit. Subcontractors are to INCLUDE in their proposed price for the work, all costs associated with the twenty-five (\$25) per day work permit for every non-Indian individual employed on this project.

Performance and Payment Bond Requirements: (Subcontractor contracts Only)

Costs for performance and payment bonds **shall be included in your base bid and any applicable alternates or unit prices.** All exterior envelope Bid Packages (Trades) will be required to bond. In addition, all base bids, combination base Bid and including all alternates of \$100,000 or above will require Performance and Payment Bond equal to one hundred percent (100%) of the contract amount. Reference Section 00 60 04 – Exhibit B of the C.M. Bid Manual.

No obligation shall be incurred by the Owner or Foreman Manhattan Construction Team to any Bidder by reason of the issuance of these written instructions, by any notification relating to this bid, or by any act other than the execution of a written Subcontract Agreement between Foreman Manhattan Construction Team and the Bidder.

APPLICABLE SPECIFICATIONS:

DIVISION 00 – Foreman Manhattan’s Construction Manager’s Bid Manual	Complete
<u>BID PACKAGE 01 (March 6, 2018)</u>	
DIVISION 00 – Procurement Requirements and Contracting Requirements	
00 0102 – Project Information	As Applicable
00 0105 – Geotechnical Data	As Applicable
DIVISION 01 – General Requirements	As Applicable
DIVISION 03 – Concrete	
03 3000 – Cast in Place Concrete	As Applicable
DIVISION 31 – EARTHWORK	
31 2000 – Earthwork	As Applicable
31 2319 – Dewatering	As Applicable
31 2500 – Erosion and Sedimentation Control	As Applicable
31 5000 – Excavation Support and Protection	As Applicable
31 6329 – Drilled Concrete Piers and Shafts	As Applicable
DIVISION 32 – SITE IMPROVEMENTS	
32 9200 – Turf and Grasses	As Applicable
DIVISION 33 – UTILITIES	
Section 33 5100 – Private Storm Sewer	As Applicable
Legends, Notes and Schedules per Plans and Specifications	As Applicable

Geotechnical Engineering Report by Building & Earth Sciences, Inc. dated January 17, 2018

As Applicable

BID PACKAGE 02 (March 27, 2018)

DIVISION 07 – THERMAL AND MOISTURE PROTECTION

07 1300 – Sheet Waterproofing

As Applicable

07 2100 – Thermal Insulation

As Applicable

DIVISION 22 – PLUMBING

22 1113 – Water Distribution

As Applicable

22 1313 – Private Sanitary Sewerage

As Applicable

22 1316 – Sanitary Waste and Vent Piping

As Applicable

DIVISION 23 – HEATING, VENTING, AND AIR CONDITIONING

23 6500 – Closed Circuit Cooling Tower

As Applicable

23 7313 – Central Station Air Handling Units

As Applicable

23 7313.1 – Central Station Air Handling Units

As Applicable

DIVISION 26 – ELECTRICAL

26 0519 – Low Voltage Electrical Power Conductors and Cables

As Applicable

26 0526 – Grounding and Bonding for Electrical Systems

As Applicable

26 0529 – Hangers and Supports for Electrical Systems

As Applicable

26 0533 – Raceways and Boxes for Electrical Systems

As Applicable

26 0543 – Underground Ducts and Raceways for Electrical Systems

As Applicable

26 0544 – Sleeves and Sleeve Seals for Electrical Raceways and Cabling

As Applicable

26 4113 – Lighting Protection for Structures

As Applicable

DIVISION 31 – EARTHWORK

31 3116 – Termite Control

As Applicable

BID PACKAGE 03 (April 16, 2018)

DIVISION 03 - CONCRETE

03 4500 PRECAST ARCHITECTURAL CONCRETE

As Applicable

DIVISION 04 - MASONRY

04 4301 STONE MASONRY VENEER DIVISION

As Applicable

05 - METALS

05 1200 STRUCTURAL STEEL FRAMING

As Applicable

05 5150 FIXED METAL LADDERS

As Applicable

DIVISION 06 - WOOD, PLASTICS, AND COMPOSITES

06 1000 ROUGH CARPENTRY

As Applicable

06 1110 WOOD BLOCKING AND CURBING

As Applicable

DIVISION 07 - THERMAL AND MOISTURE PROTECTION

07 1300 SHEET WATERPROOFING

As Applicable

07 1310 WATER REPELLENTS

As Applicable

07 2100 THERMAL INSULATION

As Applicable

07 2119 FOAMED-IN-PLACE INSULATION

As Applicable

07 2120 POLYISOCYANURATE INSULATION

As Applicable

07 2400 EXTERIOR INSULATION AND FINISH SYSTEMS

As Applicable

07 2510 FLUID APPLIED VAPOR PERMEABLE AIR BARRIER MEMBRANE

As Applicable

07 4113 METAL ROOF PANELS

As Applicable

07 4213 METAL WALL PANELS

As Applicable

07 4600 FIBER CEMENT SIDING

As Applicable

07 5200 MODIFIED BITUMINOUS MEMBRANE ROOFING

As Applicable

07 6200 SHEET METAL FLASHING AND TRIM

As Applicable

07 8100 APPLIED FIREPROOFING

As Applicable

07 8400 FIRESTOPPING

As Applicable

07 9000 JOINT SEALERS

As Applicable

DIVISION 08 - OPENINGS

08 1113 HOLLOW METAL DOORS AND FRAMES

As Applicable

08 3323 OVERHEAD COILING DOORS

As Applicable

08 4229 AUTOMATIC ENTRANCES

As Applicable

08 4233 REVOLVING DOOR ENTRANCES

As Applicable

08 4300 ALUMINUM STOREFRONT ENTRANCES

As Applicable

08 4310 ALUMINUM STOREFRONT WINDOW SYSTEMS

As Applicable

08 4400 GLAZED ALUMINUM CURTAIN WALL SYSTEMS3

As Applicable

08 7100 DOOR HARDWARE

As Applicable

08 8150 GLASS

As Applicable

DIVISION 09 – FINISHES

09 2116 GYPSUM BOARD ASSEMBLIES

As Applicable

09 5100 ACOUSTICAL CEILINGS

As Applicable

09 9000 PAINTINGS AND COATINGS

As Applicable

DIVISION 10 – SPECIALTIES

10 2226 OPERABLE PARTITIONS

10 7500 FLAGPOLES

COMPLETE

10 8200 ROOF TOP EQUIPMENT SCREENS

As Applicable

As Applicable

DIVISION 11 - EQUIPMENT

11 1313 LOADING DOCK BUMPERS

As Applicable

11 1316 LOADING DOCK SEALS AND SHELTERS

As Applicable

11 1319.13 LOADING DOCK LEVELERS

As Applicable

BID PACKAGE 04 (April 20, 2018)

DIVISION 32 – EXTERIOR IMPROVEMENTS

32 1216 ASPHALT PAVING

As Applicable

32 1313 CONCRETE PAVING

As Applicable

32 1373 CONCRETE PAVING JOINT SEALANTS

As Applicable

32 1723 PAVEMENT MARKINGS

As Applicable

32 3113 CHAIN LINK FENCES AND GATES

As Applicable

BID PACKAGE 05 (May 3, 2018)

DIVISION 6 –WOODS, PLASTICS AND COMPOSITES

06 2000 FINISH CARPENTRY

As Applicable

06 4100 ARCHITECTURAL WOOD CASEWORK

As Applicable

06 8300 HIGH PRESSURE DECORATIVE LAMINATES

As Applicable

DIVISION 8 –OPENINGS

08 1416 FLUSH WOOD DOORS

As Applicable

08 3100 ACCESS DOORS & PANELS

As Applicable

08 3313 COILING COUNTER DOORS

As Applicable

08 3323 OVERHEAD COILING DOORS

As Applicable

DIVISION 9 –FINISHES

09 3050 TILE

As Applicable

09 6500 RESILIENT FLOORING & BASE

As Applicable

09 6813 TILE CARPETING

As Applicable

09 6900 ACCESS FLOORING

As Applicable

09 9100 PAINTS AND COATINGS

As Applicable

09 9600 RESINOUS FLOOR COATINGS

As Applicable

DIVISION 10 –SPECIALTIES

10 2113.19 PLASTIC TOILET COMPARTMENTS

As Applicable

10 2601 WALL AND CORNER GUARDS

As Applicable

10 2615 HIGH IMPACT WALL COVERING

As Applicable

10 2800 TOILET ACCESSORIES

As Applicable

10 4400 FIRE PROTECTION SPECIALTIES

As Applicable

10 5100 LOCKERS

As Applicable

DIVISION 11 –EQUIPMENT

11 4000 FOODSERVICE EQUIPMENT

As Applicable

DIVISION 22 – PLUMBING

22 05 13 COMMON MOTOR REQUIREMENTS FOR PLUMBING EQUIPMENT

As Applicable

22 05 16 EXPANSION FITTINGS AND LOOPS FOR PLUMBING PIPING

As Applicable

22 05 17 SLEEVES AND SLEEVE SEALS FOR PLUMBING PIPING

As Applicable

22 05 18 ESCUTCHEONS FOR PLUMBING PIPING

As Applicable

22 05 19 METERS AND GAGES FOR PLUMBING PIPING

As Applicable

22 05 23 GENERAL-DUTY VALVES FOR PLUMBING PIPING

As Applicable

22 05 29 HANGERS AND SUPPORTS FOR PLUMBING PIPING AND EQUIPMENT

As Applicable

22 05 48 VIBRATION AND SEISMIC CONTROLS FOR PLUMBING PIPING AND EQUIPMENT

As Applicable

22 05 53 IDENTIFICATION FOR PLUMBING PIPING AND EQUIPMENT

As Applicable

22 07 16 PLUMBING EQUIPMENT INSULATION

As Applicable

22 07 19 PLUMBING PIPING INSULATION

As Applicable

22 08 00 COMMISSIONING OF PLUMBING SYSTEMS

As Applicable

22 11 16 DOMESTIC WATER PIPING

As Applicable

22 11 19 DOMESTIC WATER PIPING SPECIALITIES	As Applicable
22 11 23 DOMESTIC WATER PUMPS	As Applicable
22 13 16 SANITARY WASTE AND VENT PIPING	As Applicable
22 13 19 SANITARY WASTE PIPING SPECIALITIES	As Applicable
22 42 13.13 COMMERCIAL WATER CLOSETS	As Applicable
22 42 13.16 COMMERCIAL URINALS	As Applicable
22 42 16.13 COMMERCIAL LAVATORIES	As Applicable
22 42 16.16 COMMERCIAL SINKS	As Applicable
22 47 16 PRESSURE WATER COOLERS	As Applicable
DIVISION 23 – HEATING VENTILATING AND AIR-CONDITIONING (HVAC)	
23 00 01 HVAC GENERAL REQUIREMENTS	As Applicable
23 00 02 BASIC HVAC MATERIALS AND METHODS	As Applicable
23 05 16 PIPE EXPANSION FITTINGS AND LOOPS	As Applicable
23 05 18 ESCUTCHEONS FOR HVAC PIPING	As Applicable
23 05 19 HVAC METERS AND GAGES	As Applicable
23 05 23 VALVES	As Applicable
23 05 29 HANGERS AND SUPPORTS	As Applicable
23 05 48 HVAC VIBRATION CONTROLS	As Applicable
23 05 53 MECHANICAL IDENTIFICATION	As Applicable
23 05 93 TESTING, ADJUSTING, AND BALANCING	As Applicable
23 07 13 DUCT INSULATION	As Applicable
23 07 17 EQUIPMENT INSULATION	As Applicable
23 07 19 HVAC PIPE INSULATION	As Applicable
23 08 00 COMMISSIONING OF HVAC SYSTEMS	As Applicable
23 09 00 AUTOMATIC TEMPERATURE CONTROL SYSTEMS	As Applicable
23 09 93 SEQUENCE OF OPERATIONS	As Applicable
23 21 13 HYDRONIC PIPING	As Applicable
23 21 23 HYDRONIC PUMPS	As Applicable
23 23 00 REFRIGERANT PIPING	As Applicable
23 25 00 HVAC WATER TREATMENT	As Applicable
23 31 13 HVAC DUCTS	As Applicable
23 33 0 DUCT ACCESSORIES	As Applicable
23 34 23 HVAC POWER VENTILATORS	As Applicable
23 36 00 AIR TERMINAL UNITS	As Applicable
23 37 13 DIFFUSERS, REGISTERS, AND GRILLES	As Applicable
23 51 00 BREECHINGS, CHIMNEYS, AND STACKS	As Applicable
23 52 16 CONDENSING BOILERS	As Applicable
23 64 18.1 MODULAR CENTRAL PLANT	As Applicable
23 65 00 CLOSED CIRCUIT COOLERS	As Applicable
23 73 13 AIR-HANDLING UNIT	As Applicable
23 73 13.1 AIR HANDLING UNIT / DEDICATED OUTDOOR AIR SYSTEM / ENERGY RECOVERY UNIT	As Applicable
23 82 19 FAN -COIL UNITS	As Applicable
23 82 39 UNIT HEATERS	As Applicable
DIVISION 26 – ELECTRICAL	
26 05 19 LOW-VOLTAGE ELECTRICAL POWER CONDUCTORS AND CABLES	As Applicable
26 05 26 GROUNDING AND BONDING FOR ELECTRICAL SYSTEMS	As Applicable
26 05 29 HANGERS AND SUPPORTS FOR ELECTRICAL SYSTEMS	As Applicable
26 05 33 RACEWAYS AND BOXES FOR ELECTRICAL SYSTEMS	As Applicable
26 05 43 UNDERGROUND DUCTS AND RACEWAYS FOR ELECTRICAL SYSTEMS	As Applicable
26 05 44 SLEEVES AND SLEEVE SEALS FOR ELECTRICAL RACEWAYS AND CABLING	As Applicable
26 05 53 IDENTIFICATION FOR ELECTRICAL SYSTEMS	As Applicable
26 05 72 OVERCURRENT PROTECTIVE DEVICE SHORT-CIRCUIT STUDY	As Applicable
26 05 73 OVERCURRENT PROTECTIVE DEVICE COORDINATION STUDY	As Applicable
26 05 74 OVERCURRENT PROTECTIVE DEVICE ARC-FLASH STUDY	As Applicable
26 22 00 LOW-VOLTAGE TRANSFORMERS	As Applicable
26 24 13 SWITCHBOARDS	As Applicable
26 24 16 PANELBOARDS	As Applicable
26 27 26 WIRING DEVICES	As Applicable
26 28 13 FUSES	As Applicable
26 28 16 ENCLOSED SWITCHES AND CIRCUIT BREAKERS	As Applicable
26 29 13.03 MANUAL AND MAGNETIC MOTOR CONTROLLERS	As Applicable
26 32 13.13 DIESEL EMERGENCY ENGINE GENERATORS	As Applicable

26 33 53	STATIC UNINTERRUPTIBLE POWER SUPPLY	As Applicable
26 36 00	TRANSFER SWITCHES	As Applicable
26 41 13	LIGHTNING PROTECTION FOR STRUCTURES	As Applicable
26 51 19	LED INTERIOR LIGHTING	As Applicable
26 52 19	EMERGENCY AND EXIT LIGHTING	As Applicable
26 56 13	LIGHT POLES AND STANDARDS	As Applicable
26 56 19	LED EXTERIOR LIGHTING	As Applicable
DIVISION 28 – ELECTRONIC SAFETY AND SECURITY		
28 31 11	DIGITAL, ADDRESSABLE FIRE ALARM AND EMERGENCY COMMUNICATIONS SYSTEM	As Applicable

Terminology:

Contractor and/or Subcontractor shall mean Scope Package Bidder.

Construction Manager (CM) shall mean Foreman Manhattan Construction Team.

SCOPE OF WORK:

Includes, but is not limited to, providing all the necessary labor, materials, tools, supplies, supervision, insurance, equipment, scaffolding, hoisting, fees, etc. necessary to provide the **OPERABLE PARTITIONS at the CNE Tahlequah Casino**, Tahlequah, Oklahoma in accordance with the Contract Documents. It is further understood and agreed that this Subcontract also includes the furnishing and installation of the below listed items regardless of whether or not they are in the listed specification section(s) or any other specification section(s), or shown on the plans. This scope listing is to be used as a guideline and should not be considered as an all-inclusive list of items required to provide a complete scope of work under this proposal. Drawing and detail references are provided for reference only and are not to be considered as all-inclusive of Contract Documents for the particular items referenced. **(Please note: The word “provide” when used herein shall mean furnish and install completely, including all costs for labor, materials, equipment, hoisting, layout, scaffolding, ladders, staging, tools, rigging and any other appurtenances necessary to complete the Work”.)** Subcontractor has familiarized himself with the documents and has included those items of work shown and noted on the documents and all other equipment, devices and components that are not shown or noted, but required to provide a complete, functional and working system that is in compliance with all Federal, state and local codes.

1. Provide complete **Operable Partitions** in accordance with specification section **102226** required by the contract documents.
2. Provide complete Folding panel partition submittal package, professionally engineered shop drawing documents within two (2) weeks of receiving executed contract.
3. Provide detailed drawings indicating in-wall blocking, above ceiling, or other support requirements for installation before the drywall installation.
4. Provide all operable partition door hardware and attachment rods, fasteners, to structure above or on jamb sides of partitions.
5. Provide all patterns and special finishes applied to operable partitions as shown, noted, and scheduled.
6. Provide all field drilling into structure for suspension systems as required.
7. Provide all seismic design and seismic bracing for folding panel partitions.
8. Include a separate mobilization to install the track and supporting structure in order to finish the ceiling systems.
9. Provide panels with required Sound Transmission Coefficient (STC) ratings.
10. Provide all seals, trolleys, tracks, guides, anchors, screws, shims, caulking (match color), adhesives and any other items necessary to complete the installation.
11. Handle, ship, and store materials in such a manner that it will not be damaged or deformed. Upon receipt, all material having defects will be rejected, shall not be used, and shall be replaced immediately by this contractor at no additional cost.
12. Provide all unloading of material upon delivery to the project site, inventory same, and inspect for shipping damage.
13. Subcontractor shall be responsible for moving material from the storage area to each respective opening for installation. Any items damaged due to this relocation process shall be repaired or replaced by this contractor at no additional cost.
14. Subcontractor shall be responsible for verifying in-place construction and primary supports. Report in writing to Construction Manager any conditions detrimental to proper and timely completion of work in accordance with the Contract Documents.
15. Coordinate any ceiling hung supports with structure steel provider, including but not limited to associated hardware and above ceiling supports.
16. All items shall be installed plumb, level and securely anchored to substrate.
17. Cost of material replacement for damaged or miss cut materials furnished by others shall be borne by this contractor.
18. Provide touch up of marred finishes, or replace fabrics and or finishes as necessary if damaged during installation.
19. Provide all cleaning and final protection of panels and panel doors until substantial completion.
20. Provide all extra materials as indicated and required.
21. Furnish, install and remove any temporary protection required for protecting existing improvements, work of other trades, and floors or building finishes from damage from material deliveries or work activities of this contractor. This also includes protection and proper storage of materials for this scope of work.
22. **Bidders to include a \$25 / SY Wall Covering Allowance for partition finished surfaces. Partitions to arrive with wall covering pre-installed as broken out on the bid form.**

GENERAL ITEMS

23. Include separate mobilizations / demobilizations as required by the Project Schedule and Phasing Plans.

24. Provide all shop drawings, product data, sample and other pertinent submittals for the work of this Subcontract. Provide engineering and printing costs for all shop drawings, coordination drawings, and product submittals for architect approval as required to properly coordinate the work included in this Subcontract with other trades. Include costs for revising and resubmitting shop/ coordination drawings as needed.
25. Subcontractor will assist Foreman Manhattan with providing material quantities and cost breakdowns as required for the Owner's and Foreman Manhattan's budget requirements. All breakouts specified in this subcontract will be used for accounting purposes and tracking only.
26. Contractor shall provide a complete installation that complies with all applicable codes, ordinances and satisfying all Authorities Having Jurisdiction.
27. Provide all field engineering and layout from benchmarks and base building control (benchmarks and baseline control is furnished by others). This Subcontractor is responsible for replacement of any damaged benchmarks, base line control or layout work of other trades/packages damaged or destroyed by the work of this work package.
28. Provide all required pedestrian protection, traffic control and protection including flagman, barricades, signage, etc. as required for the work, and as may be required for protection for equipment access, deliveries and loading.
29. Subcontractor is required to comply with requirements to control Dust and Airborne Contaminants. No waste materials or debris shall be allowed to accumulate.
30. Provide coordination, assistance, and necessary access for the Owner's furnished Testing Laboratory, including notification, obtaining samples and data gathering as required for scope of work. Costs for retesting due to failed tests and/or for Subcontractor's unpreparedness, will be paid by this Subcontractor.
31. It is mutually understood and agreed that this subcontractor will coordinate all of the scheduled deliveries of these items being furnished by others with the Foreman Manhattan designated representative. This includes the on or off site storage, staging, inventory control, and shipping to the site. All damages or shortages are to be reported within 24 hours of delivery.
32. Subcontractor agrees to be bound by the Welcome Package issued by the Foreman Manhattan Field staff.
33. **Revise paragraph 1.2.3 of section 00 60 02A Manhattan General Provisions as contained in the Construction Manager's Bid manual as follows:**
Until Subcontractor's obligations under this Subcontract are completely fulfilled, Subcontractor agrees not to perform any changes to the work directly for Owner or any of its tenants, or deal directly with Owner's representatives with respect to the work and/or changes to the work, in connection with the Project, unless approved in writing by Foreman Manhattan. Foreman Manhattan understands that the Owner and specifically TERO shall communicate directly with the subcontractor to maintain a spirit of cooperation and also to utilize the TERO Job Bank to the fullest extent giving first hire priority rights to Cherokee Citizens.
34. **The Owner requirements for funding for work in progress is to provide payment less retainage of ten percent (10%), which shall be withheld and paid, without interest, upon final completion of the entire project.**
35. The terms and conditions contained in the following documents including General Provisions, Article 2.5, "Indemnification" as included within the contract documents; are incorporated herein by reference as if fully written out;
 - Foreman Manhattan General Provisions 2012
 - Exhibit A – (Scope of Work)
 - Exhibit B – (Bond Forms)
 - Exhibit C – (Insurance Requirements / Sample)
 - Exhibit D – (Contract Documents)
 - Exhibit E – (Special Conditions)
 - Exhibit F – (Project Schedule)
 - Exhibit G – Tax Exempt – O.D.P.I.
 - Exhibit H – (Foreman Manhattan Additional Safety Requirements)

SCOPE OF WORK EXCLUSIONS:

The following items are excluded from this Subcontract:

1. Dumpsters

Value Analysis Suggestions:

Please write in the box below any suggestions for cost savings / value analysis which were discovered during the course of bidding this project, along with a dollar value for each item. VA Suggestions may be included in the criteria considered for successful subcontractor selection. Attach additional sheet(s) if necessary.

1. < \$ _____ > Savings
Description:

2. < \$ _____ > Savings
Description:

3. < \$ _____ > Savings
Description:

4. < \$ _____ > Savings
Description:

5. < \$ _____ > Savings
Description:

CNE TAHLEQUAH CASINO
BP 10.01 OPERABLE PARTITIONS
ALTERNATE #1 LAYOUT

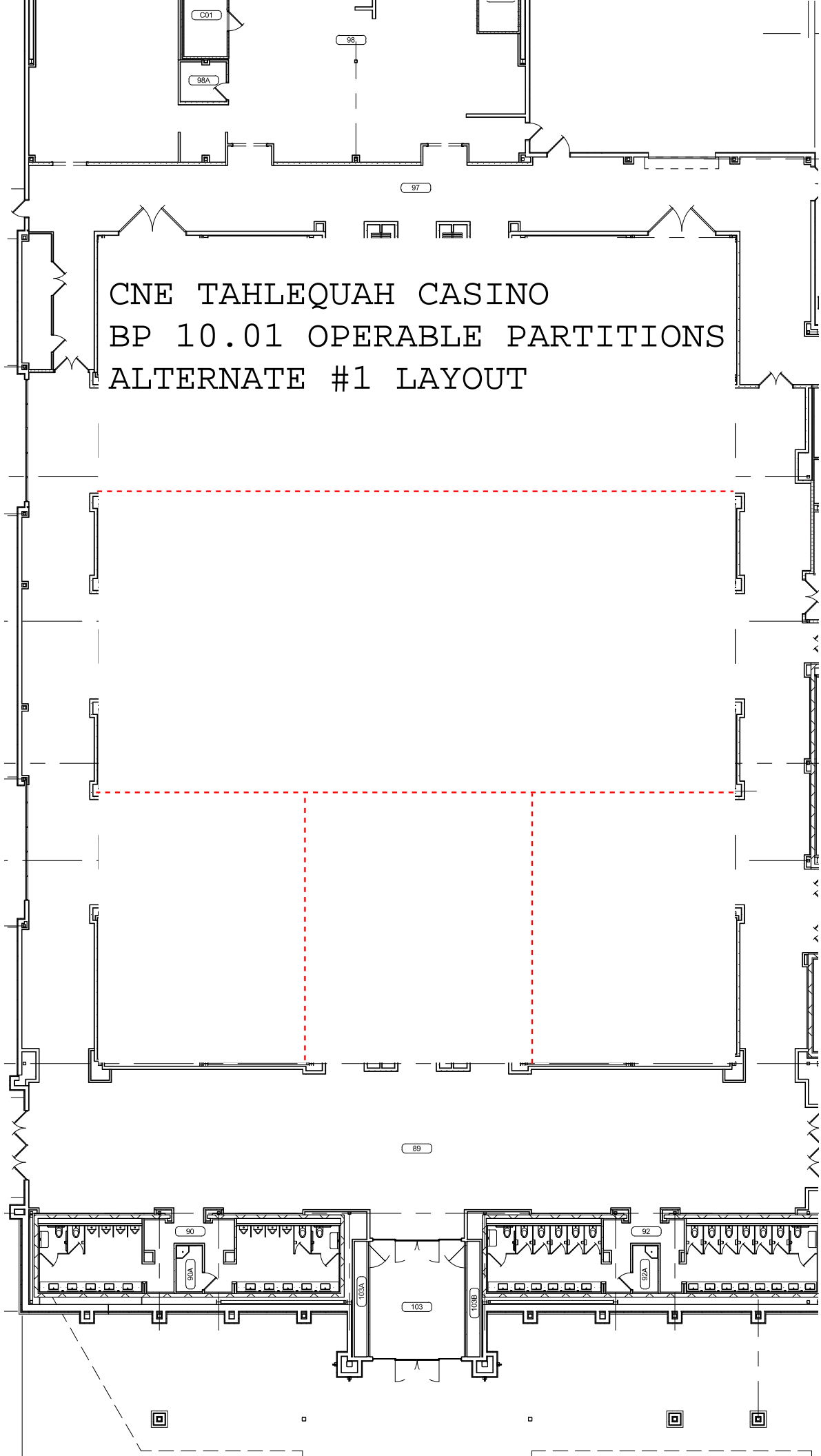

BID PACKAGE – CNE Tahlequah Casino: SCOPE PACKAGE 21.01 – FIRE SUPRESSION SYSTEM

Submitted by (Company Name per W-9 Form): _____

Provide the following *Lump Sum Proposal* as requested in accordance with all scope items listed in Scope of Work.

BASE BID – FIRE SUPRESSION SYSTEM: \$ _____

BID ALTERNATES:

Alternates shall be inclusive of all required labor, materials and equipment in accordance with all general scope items listed in the Exhibit "A" Scope of Work:

(none)

Other Comments:

Contact Name: _____

Address: _____

Phone/Fax: _____

Email: _____

Signature: _____

By acknowledging items below, bidder certifies acceptance of these documents and that all associated costs have been included in the proposal amount. Any and all exceptions/comments to these documents must be attached to this proposal. Comments or requested revisions to these documents will not be accepted after this proposal date.

TERO bidders must supply a copy of TERO Certificate, front of back

Non-Collusion Affidavit

Business Relationship Affidavit

Acknowledge all scope of work items listed under scope of work (See Exhibit A)

Acknowledge Exhibits B, C, D, E, F, G, H

Addenda Included

MCC Clarifications Included

Acknowledge and agree to Foreman Manhattan Standard Subcontract Agreement/Special Terms and Conditions as per Exhibit E

Acknowledge and agree to Manhattan General Provisions as Included in the Bid Documents

SCHEDULE/EXPEDITING/SUBMITTALS
Foreman Manhattan Construction Target Schedule is attached. Please verify supplier is able to meet Foreman Manhattan required installation dates.

Sales Tax

All bids must be submitted exclusive of Federal Excise Tax and Oklahoma State Sales Tax. The Cherokee Nation is exempt from Oklahoma State Sales Tax and Federal Excise Tax under authority of § Okla. Stat. Supp. 1994 Section 1356. Bidder is to include and pay all other applicable sales tax and use taxes as required. Applications for payment shall be broken down as required by the Owner or Construction Manager.

Specific Project Requirements for the process, approval, and payment of Owner-Direct Payment Items (ODPI) are identified in section 00 60 09:

EXHIBIT “G” Tax Exempt / Owner Direct Paid Invoice (ODPI) Payment Process

Tribal Employment Rights Office.

SUBCONTRACTOR IS TO COMPLY WITH ALL CHEROKEE NATION, TRIBAL EMPLOYMENT RIGHTS OFFICE (TERO), NATIONAL INDIAN GAMING ASSOCIATION (NIGA), AND ALL BUREAU OF INDIAN AFFAIRS (BIA) RULES, REGULATIONS, AND LICENSING REQUIREMENTS INCLUDING ALL FEES AND ASSESSMENTS, ASSESSMENT, APPLICABLE TO THIS PROJECT.

11.1.1 - TERO document “An Act” Legislative Act 01-14 dated February 10, 2014.
This Document is ACT AMENDING LA 30-12, "CHEROKEE NATION EMPLOYMENT RIGHTS ACT"

11.1.2 - Subcontractors are to EXCLUDE the cost for Section; Title 40, § 1011; T.
To assess an Employee Rights Fee of one-half (1/2) of one percent (1%) on all covered contracts. This cost will be paid by the Construction Manager.

11.1.3 - The Work Permits paragraph of the Tribal Employment Rights Office (TERO) Project Labor Agreement - Master Agreement LA 01-14 states: No person who is not a member of a federally recognized tribe shall be employed by a covered employer until he or she has obtained a work permit from the TERO at a cost of twenty-five dollars (\$25) per day, per permit. Subcontractors are to INCLUDE in their proposed price for the work, all costs associated with the twenty-five (\$25) per day work permit for every non-Indian individual employed on this project.

Performance and Payment Bond Requirements: (Subcontractor contracts Only)

Costs for performance and payment bonds **shall be included in your base bid and any applicable alternates or unit prices.** All exterior envelope Bid Packages (Trades) will be required to bond. In addition, all base bids, combination base Bid and including all alternates of \$100,000 or above will require Performance and Payment Bond equal to one hundred percent (100%) of the contract amount. Reference Section 00 60 04 – Exhibit B of the C.M. Bid Manual.

No obligation shall be incurred by the Owner or Foreman Manhattan Construction Team to any Bidder by reason of the issuance of these written instructions, by any notification relating to this bid, or by any act other than the execution of a written Subcontract Agreement between Foreman Manhattan Construction Team and the Bidder.

APPLICABLE SPECIFICATIONS:

DIVISION 00 – Foreman Manhattan’s Construction Manager’s Bid Manual	Complete
<u>BID PACKAGE 01 (March 6, 2018)</u>	
DIVISION 00 – Procurement Requirements and Contracting Requirements	
00 0102 – Project Information	As Applicable
00 0105 – Geotechnical Data	As Applicable
DIVISION 01 – General Requirements	As Applicable
DIVISION 03 – Concrete	
03 3000 – Cast in Place Concrete	As Applicable
DIVISION 31 – EARTHWORK	
31 2000 – Earthwork	As Applicable
31 2319 – Dewatering	As Applicable
31 2500 – Erosion and Sedimentation Control	As Applicable
31 5000 – Excavation Support and Protection	As Applicable
31 6329 – Drilled Concrete Piers and Shafts	As Applicable
DIVISION 32 – SITE IMPROVEMENTS	
32 9200 – Turf and Grasses	As Applicable
DIVISION 33 – UTILITIES	
Section 33 5100 – Private Storm Sewer	As Applicable
Legends, Notes and Schedules per Plans and Specifications	As Applicable
Geotechnical Engineering Report by Building & Earth Sciences, Inc. dated January 17, 2018	As Applicable

BID PACKAGE 02 (March 27, 2018)

DIVISION 07 – THERMAL AND MOISTURE PROTECTION

07 1300 – Sheet Waterproofing As Applicable
07 2100 – Thermal Insulation As Applicable

DIVISION 22 – PLUMBING

22 1113 – Water Distribution As Applicable
22 1313 – Private Sanitary Sewerage As Applicable
22 1316 – Sanitary Waste and Vent Piping As Applicable

DIVISION 23 – HEATING, VENTING, AND AIR CONDITIONING

23 6500 – Closed Circuit Cooling Tower As Applicable
23 7313 – Central Station Air Handling Units As Applicable
23 7313.1 – Central Station Air Handling Units As Applicable

DIVISION 26 – ELECTRICAL

26 0519 – Low Voltage Electrical Power Conductors and Cables As Applicable
26 0526 – Grounding and Bonding for Electrical Systems As Applicable
26 0529 – Hangers and Supports for Electrical Systems As Applicable
26 0533 – Raceways and Boxes for Electrical Systems As Applicable
26 0543 – Underground Ducts and Raceways for Electrical Systems As Applicable
26 0544 – Sleeves and Sleeve Seals for Electrical Raceways and Cabling As Applicable
26 4113 – Lighting Protection for Structures As Applicable

DIVISION 31 – EARTHWORK

31 3116 – Termite Control As Applicable

BID PACKAGE 03 (April 16, 2018)

DIVISION 03 - CONCRETE

03 4500 PRECAST ARCHITECTURAL CONCRETE As Applicable

DIVISION 04 - MASONRY

04 4301 STONE MASONRY VENEER DIVISION As Applicable

05 - METALS

05 1200 STRUCTURAL STEEL FRAMING As Applicable
05 5150 FIXED METAL LADDERS As Applicable

DIVISION 06 - WOOD, PLASTICS, AND COMPOSITES

06 1000 ROUGH CARPENTRY As Applicable
06 1110 WOOD BLOCKING AND CURBING As Applicable

DIVISION 07 - THERMAL AND MOISTURE PROTECTION

07 1300 SHEET WATERPROOFING As Applicable
07 1310 WATER REPELLENTS As Applicable
07 2100 THERMAL INSULATION As Applicable
07 2119 FOAMED-IN-PLACE INSULATION As Applicable
07 2120 POLYISOCYANURATE INSULATION As Applicable
07 2400 EXTERIOR INSULATION AND FINISH SYSTEMS As Applicable
07 2510 FLUID APPLIED VAPOR PERMEABLE AIR BARRIER MEMBRANE As Applicable

07 4113 METAL ROOF PANELS

07 4213 METAL WALL PANELS As Applicable
07 4600 FIBER CEMENT SIDING As Applicable

07 5200 MODIFIED BITUMINOUS MEMBRANE ROOFING

07 6200 SHEET METAL FLASHING AND TRIM As Applicable
07 8100 APPLIED FIREPROOFING As Applicable
07 8400 FIRESTOPPING As Applicable
07 9000 JOINT SEALERS As Applicable

DIVISION 08 - OPENINGS

08 1113 HOLLOW METAL DOORS AND FRAMES As Applicable
08 3323 OVERHEAD COILING DOORS As Applicable
08 4229 AUTOMATIC ENTRANCES As Applicable
08 4233 REVOLVING DOOR ENTRANCES As Applicable
08 4300 ALUMINUM STOREFRONT ENTRANCES As Applicable
08 4310 ALUMINUM STOREFRONT WINDOW SYSTEMS As Applicable
08 4400 GLAZED ALUMINUM CURTAIN WALL SYSTEMS3 As Applicable
08 7100 DOOR HARDWARE As Applicable
08 8150 GLASS As Applicable

DIVISION 09 – FINISHES

09 2116 GYPSUM BOARD ASSEMBLIES As Applicable
09 5100 ACOUSTICAL CEILINGS As Applicable
09 9000 PAINTINGS AND COATINGS As Applicable

DIVISION 10 – SPECIALTIES

10 2226 OPERABLE PARTITIONS As Applicable
10 7500 FLAGPOLES As Applicable
10 8200 ROOF TOP EQUIPMENT SCREENS As Applicable

DIVISION 11 - EQUIPMENT

11 1313 LOADING DOCK BUMPERS As Applicable
11 1316 LOADING DOCK SEALS AND SHELTERS As Applicable
11 1319.13 LOADING DOCK LEVELERS As Applicable

BID PACKAGE 04 (April 20, 2018)

DIVISION 32 – EXTERIOR IMPROVEMENTS

32 1216 ASPHALT PAVING As Applicable
32 1313 CONCRETE PAVING As Applicable
32 1373 CONCRETE PAVING JOINT SEALANTS As Applicable
32 1723 PAVEMENT MARKINGS As Applicable
32 3113 CHAIN LINK FENCES AND GATES As Applicable

BID PACKAGE 05 (May 3, 2018)

DIVISION 6 –WOODS, PLASTICS AND COMPOSITES

06 2000 FINISH CARPENTRY As Applicable
06 4100 ARCHITECTURAL WOOD CASEWORK As Applicable
06 8300 HIGH PRESSURE DECORATIVE LAMINATES As Applicable

DIVISION 8 –OPENINGS

08 1416 FLUSH WOOD DOORS As Applicable
08 3100 ACCESS DOORS & PANELS As Applicable
08 3313 COILING COUNTER DOORS As Applicable
08 3323 OVERHEAD COILING DOORS As Applicable

DIVISION 9 –FINISHES

09 3050 TILE As Applicable
09 6500 RESILIENT FLOORING & BASE As Applicable
09 6813 TILE CARPETING As Applicable
09 6900 ACCESS FLOORING As Applicable
09 9100 PAINTS AND COATINGS As Applicable
09 9600 RESINOUS FLOOR COATINGS As Applicable

DIVISION 10 –SPECIALTIES

10 2113.19 PLASTIC TOILET COMPARTMENTS As Applicable
10 2601 WALL AND CORNER GUARDS As Applicable
10 2615 HIGH IMPACT WALL COVERING As Applicable
10 2800 TOILET ACCESSORIES As Applicable
10 4400 FIRE PROTECTION SPECIALTIES As Applicable
10 5100 LOCKERS As Applicable

DIVISION 11 –EQUIPMENT

11 4000 FOODSERVICE EQUIPMENT As Applicable

DIVISION 22 – PLUMBING

22 05 13 COMMON MOTOR REQUIREMENTS FOR PLUMBING EQUIPMENT As Applicable
22 05 16 EXPANSION FITTINGS AND LOOPS FOR PLUMBING PIPING As Applicable
22 05 17 SLEEVES AND SLEEVE SEALS FOR PLUMBING PIPING As Applicable
22 05 18 ESCUTCHEONS FOR PLUMBING PIPING As Applicable
22 05 19 METERS AND GAGES FOR PLUMBING PIPING As Applicable
22 05 23 GENERAL-DUTY VALVES FOR PLUMBING PIPING As Applicable
22 05 29 HANGERS AND SUPPORTS FOR PLUMBING PIPING AND EQUIPMENT As Applicable
22 05 48 VIBRATION AND SEISMIC CONTROLS FOR PLUMBING PIPING AND EQUIPMENT As Applicable
22 05 53 IDENTIFICATION FOR PLUMBING PIPING AND EQUIPMENT As Applicable
22 07 16 PLUMBING EQUIPMENT INSULATION As Applicable
22 07 19 PLUMBING PIPING INSULATION As Applicable
22 08 00 COMMISSIONING OF PLUMBING SYSTEMS As Applicable
22 11 16 DOMESTIC WATER PIPING As Applicable
22 11 19 DOMESTIC WATER PIPING SPECIALITIES As Applicable

22 11 23 DOMESTIC WATER PUMPS	As Applicable
22 13 16 SANITARY WASTE AND VENT PIPING	As Applicable
22 13 19 SANITARY WASTE PIPING SPECIALITIES	As Applicable
22 42 13.13 COMMERCIAL WATER CLOSETS	As Applicable
22 42 13.16 COMMERCIAL URINALS	As Applicable
22 42 16.13 COMMERCIAL LAVATORIES	As Applicable
22 42 16.16 COMMERCIAL SINKS	As Applicable
22 47 16 PRESSURE WATER COOLERS	As Applicable
DIVISION 23 – HEATING VENTILATING AND AIR-CONDITIONING (HVAC)	
23 00 01 HVAC GENERAL REQUIREMENTS	As Applicable
23 00 02 BASIC HVAC MATERIALS AND METHODS	As Applicable
23 05 16 PIPE EXPANSION FITTINGS AND LOOPS	As Applicable
23 05 18 ESCUTCHEONS FOR HVAC PIPING	As Applicable
23 05 19 HVAC METERS AND GAGES	As Applicable
23 05 23 VALVES	As Applicable
23 05 29 HANGERS AND SUPPORTS	As Applicable
23 05 48 HVAC VIBRATION CONTROLS	As Applicable
23 05 53 MECHANICAL IDENTIFICATION	As Applicable
23 05 93 TESTING, ADJUSTING, AND BALANCING	As Applicable
23 07 13 DUCT INSULATION	As Applicable
23 07 17 EQUIPMENT INSULATION	As Applicable
23 07 19 HVAC PIPE INSULATION	As Applicable
23 08 00 COMMISSIONING OF HVAC SYSTEMS	As Applicable
23 09 00 AUTOMATIC TEMPERATURE CONTROL SYSTEMS	As Applicable
23 09 93 SEQUENCE OF OPERATIONS	As Applicable
23 21 13 HYDRONIC PIPING	As Applicable
23 21 23 HYDRONIC PUMPS	As Applicable
23 23 00 REFRIGERANT PIPING	As Applicable
23 25 00 HVAC WATER TREATMENT	As Applicable
23 31 13 HVAC DUCTS	As Applicable
23 33 0 DUCT ACCESSORIES	As Applicable
23 34 23 HVAC POWER VENTILATORS	As Applicable
23 36 00 AIR TERMINAL UNITS	As Applicable
23 37 13 DIFFUSERS, REGISTERS, AND GRILLES	As Applicable
23 51 00 BREECHINGS, CHIMNEYS, AND STACKS	As Applicable
23 52 16 CONDENSING BROILERS	As Applicable
23 64 18.1 MODULAR CENTRAL PLANT	As Applicable
23 65 00 CLOSED CIRCUIT COOLERS	As Applicable
23 73 13 AIR-HANDLING UNIT	As Applicable
23 73 13.1 AIR HANDLING UNIT / DEDICATED OUTDOOR AIR SYSTEM / ENERGY RECOVERY UNIT	As Applicable
23 82 19 FAN -COIL UNITS	As Applicable
23 82 39 UNIT HEATERS	As Applicable
DIVISION 26 – ELECTRICAL	
26 05 19 LOW-VOLTAGE ELECTRICAL POWER CONDUCTORS AND CABLES	As Applicable
26 05 26 GROUNDING AND BONDING FOR ELECTRICAL SYSTEMS	As Applicable
26 05 29 HANGERS AND SUPPORTS FOR ELECTRICAL SYSTEMS	As Applicable
26 05 33 RACEWAYS AND BOXES FOR ELECTRICAL SYSTEMS	As Applicable
26 05 43 UNDERGROUND DUCTS AND RACEWAYS FOR ELECTRICAL SYSTEMS	As Applicable
26 05 44 SLEEVES AND SLEEVE SEALS FOR ELECTRICAL RACEWAYS AND CABLING	As Applicable
26 05 53 IDENTIFICATION FOR ELECTRICAL SYSTEMS	As Applicable
26 05 72 OVERCURRENT PROTECTIVE DEVICE SHORT-CIRCUIT STUDY	As Applicable
26 05 73 OVERCURRENT PROTECTIVE DEVICE COORDINATION STUDY	As Applicable
26 05 74 OVERCURRENT PROTECTIVE DEVICE ARC-FLASH STUDY	As Applicable
26 22 00 LOW-VOLTAGE TRANSFORMERS	As Applicable
26 24 13 SWITCHBOARDS	As Applicable
26 24 16 PANELBOARDS	As Applicable
26 27 26 WIRING DEVICES	As Applicable
26 28 13 FUSES	As Applicable
26 28 16 ENCLOSED SWITCHES AND CIRCUIT BREAKERS	As Applicable
26 29 13.03 MANUAL AND MAGNETIC MOTOR CONTROLLERS	As Applicable
26 32 13.13 DIESEL EMERGENCY ENGINE GENERATORS	As Applicable
26 33 53 STATIC UNINTERRUPTIBLE POWER SUPPLY	As Applicable

26 36 00	TRANSFER SWITCHES	As Applicable
26 41 13	LIGHTNING PROTECTION FOR STRUCTURES	As Applicable
26 51 19	LED INTERIOR LIGHTING	As Applicable
26 52 19	EMERGENCY AND EXIT LIGHTING	As Applicable
26 56 13	LIGHT POLES AND STANDARDS	As Applicable
26 56 19	LED EXTERIOR LIGHTING	As Applicable
DIVISION 28 – ELECTRONIC SAFETY AND SECURITY		
28 31 11	DIGITAL, ADDRESSABLE FIRE ALARM AND EMERGENCY COMMUNICATIONS SYSTEM	As Applicable

Terminology:

Contractor and/or Subcontractor shall mean Scope Package Bidder.

Construction Manager (CM) shall mean Foreman Manhattan Construction Team.

SCOPE OF WORK:

Includes, but is not limited to, providing all the necessary labor, materials, tools, supplies, supervision, insurance, equipment, scaffolding, hoisting, fees, etc. necessary to provide the **FIRE SUPPRESSION SYSTEM at the CNE Tahlequah Casino**, Tahlequah, Oklahoma in accordance with the Contract Documents. It is further understood and agreed that this Subcontract also includes the furnishing and installation of the below listed items regardless of whether or not they are in the listed specification section(s) or any other specification section(s), or shown on the plans. This scope listing is to be used as a guideline and should not be considered as an all-inclusive list of items required to provide a complete scope of work under this proposal. Drawing and detail references are provided for reference only and are not to be considered as all-inclusive of Contract Documents for the particular items referenced. **(Please note: The word “provide” when used herein shall mean furnish and install completely, including all costs for labor, materials, equipment, hoisting, layout, scaffolding, ladders, staging, tools, rigging and any other appurtenances necessary to complete the Work”.)** Subcontractor has familiarized himself with the documents and has included those items of work shown and noted on the documents and all other equipment, devices and components that are not shown or noted, but required to provide a complete, functional and working system that is in compliance with all Federal, state and local codes.

(PROJECT SCOPE TO BE ISSUED IN FORTHCOMING CLARIFICATION)

GENERAL ITEMS

1. Include separate mobilizations / demobilizations as required by the Project Schedule and Phasing Plans.
2. Provide all shop drawings, product data, sample and other pertinent submittals for the work of this Subcontract. Provide engineering and printing costs for all shop drawings, coordination drawings, and product submittals for architect approval as required to properly coordinate the work included in this Subcontract with other trades. Include costs for revising and resubmitting shop/ coordination drawings as needed.
3. Subcontractor will assist Foreman Manhattan with providing material quantities and cost breakdowns as required for the Owner’s and Foreman Manhattan’s budget requirements. All breakouts specified in this subcontract will be used for accounting purposes and tracking only.
4. Contractor shall provide a complete installation that complies with all applicable codes, ordinances and satisfying all Authorities Having Jurisdiction.
5. Provide all field engineering and layout from benchmarks and base building control (benchmarks and baseline control is furnished by others). This Subcontractor is responsible for replacement of any damaged benchmarks, base line control or layout work of other trades/packages damaged or destroyed by the work of this work package.
6. Provide all required pedestrian protection, traffic control and protection including flagman, barricades, signage, etc. as required for the work, and as may be required for protection for equipment access, deliveries and loading.
7. Subcontractor is required to comply with requirements to control Dust and Airborne Contaminants. No waste materials or debris shall be allowed to accumulate.
8. Provide coordination, assistance, and necessary access for the Owner’s furnished Testing Laboratory, including notification, obtaining samples and data gathering as required for scope of work. Costs for retesting due to failed tests and/or for Subcontractor’s unpreparedness, will be paid by this Subcontractor.
9. It is mutually understood and agreed that this subcontractor will coordinate all of the scheduled deliveries of these items being furnished by others with the Foreman Manhattan designated representative. This includes the on or off site storage, staging, inventory control, and shipping to the site. All damages or shortages are to be reported within 24 hours of delivery.
10. Subcontractor agrees to be bound by the Welcome Package issued by the Foreman Manhattan Field staff.
11. **Revise paragraph 1.2.3 of section 00 60 02A Manhattan General Provisions as contained in the Construction Manager’s Bid manual as follows:**

Until Subcontractor’s obligations under this Subcontract are completely fulfilled, Subcontractor agrees not to perform any changes to the work directly for Owner or any of its tenants, or deal directly with Owner’s representatives with respect to the work and/or changes to the work, in connection with the Project, unless approved in writing by Foreman Manhattan. Foreman Manhattan understands that

the Owner and specifically TERO shall communicate directly with the subcontractor to maintain a spirit of cooperation and also to utilize the TERO Job Bank to the fullest extent giving first hire priority rights to Cherokee Citizens.

12. **The Owner requirements for funding for work in progress is to provide payment less retainage of ten percent (10%), which shall be withheld and paid, without interest, upon final completion of the entire project.**
13. The terms and conditions contained in the following documents including General Provisions, Article 2.5, "Indemnification" as included within the contract documents; are incorporated herein by reference as if fully written out;
 - Foreman Manhattan General Provisions 2012
 - Exhibit A – (Scope of Work)
 - Exhibit B – (Bond Forms)
 - Exhibit C – (Insurance Requirements / Sample)
 - Exhibit D – (Contract Documents)
 - Exhibit E – (Special Conditions)
 - Exhibit F – (Project Schedule)
 - Exhibit G – Tax Exempt – O.D.P.I.
 - Exhibit H – (Foreman Manhattan Additional Safety Requirements)

SCOPE OF WORK EXCLUSIONS:

The following items are excluded from this Subcontract:

1. Cost of dumpsters.
2. Finish Painting
3. Electrical power or fire alarm.
4. Incoming Fire utility services to within 5' of building line.
5. Fire extinguishers and fire extinguisher cabinets.
6. Concrete equipment pads

Value Analysis Suggestions:

Please write in the box below any suggestions for cost savings / value analysis which were discovered during the course of bidding this project, along with a dollar value for each item. VA Suggestions may be included in the criteria considered for successful subcontractor selection. Attach additional sheet(s) if necessary.

1. < \$ _____ > Savings
Description:

2. < \$ _____ > Savings
Description:

3. < \$ _____ > Savings
Description:

4. < \$ _____ > Savings
Description:

5. < \$ _____ > Savings
Description:

BID PACKAGE – CNE Tahlequah Casino: SCOPE PACKAGE 23.01 – PLUMBING AND HVAC COMPLETE

Submitted by (Company Name per W-9 Form): _____

Provide the following *Lump Sum Proposal* as requested in accordance with all scope items listed in Scope of Work.

BASE BID – BREAKDOWN:

1. PLUMBING: \$ _____

2. HVAC: \$ _____

TOTAL BASE BID: \$ _____

BID ALTERNATES:

Alternates shall be inclusive of all required labor, materials and equipment in accordance with all general scope items listed in the Exhibit "A" Scope of Work:

Alternate No. 1: BIM MODELING

Provide BIM Modeling for Plumbing and HVAC Systems utilizing Architect's model. Coordinate with associated trades, and detect clashes and conflicts.

Alternate No. 1 – NET CHANGEADD / DEDUCT \$ _____ / LS

Other Comments:

Contact Name: _____

Address: _____

Phone/Fax: _____

Email: _____

Signature: _____

By acknowledging items below, bidder certifies acceptance of these documents and that all associated costs have been included in the proposal amount. Any and all exceptions/comments to these documents must be attached to this proposal. Comments or requested revisions to these documents will not be accepted after this proposal date.

TERO bidders must supply a copy of TERO Certificate, front of back

Initial:

Non-Collusion Affidavit

Initial:

Business Relationship Affidavit

Initial:

Acknowledge all scope of work items listed under scope of work (See Exhibit A)

Initial:

Acknowledge Exhibits B, C, D, E, F, G, H

Initial:

Addenda Included

#'s:

MCC Clarifications Included

#'s:

Acknowledge and agree to Foreman Manhattan Standard Subcontract Agreement/Special Terms and Conditions as per Exhibit E

Initial:

Acknowledge and agree to Manhattan General Provisions as Included in the Bid Documents

Initial:

SCHEDULE/EXPEDITING/SUBMITTALS

Foreman Manhattan Construction Target Schedule is attached. Please verify supplier is able to meet Foreman Manhattan required installation dates.

Initial:

Sales Tax

All bids must be submitted exclusive of Federal Excise Tax and Oklahoma State Sales Tax. The Cherokee Nation is exempt from Oklahoma State Sales Tax and Federal Excise Tax under authority of § Okla. Stat. Supp. 1994 Section 1356. Bidder is to include and pay all other applicable sales tax and use taxes as required. Applications for payment shall be broken down as required by the Owner or Construction Manager.

Specific Project Requirements for the process, approval, and payment of Owner-Direct Payment Items (ODPI) are identified in section 00 60 09:

EXHIBIT “G” Tax Exempt / Owner Direct Paid Invoice (ODPI) Payment Process

Tribal Employment Rights Office.

SUBCONTRACTOR IS TO COMPLY WITH ALL CHEROKEE NATION, TRIBAL EMPLOYMENT RIGHTS OFFICE (TERO), NATIONAL INDIAN GAMING ASSOCIATION (NIGA), AND ALL BUREAU OF INDIAN AFFAIRS (BIA) RULES, REGULATIONS, AND LICENSING REQUIREMENTS INCLUDING ALL FEES AND ASSESSMENTS, ASSESSMENT, APPLICABLE TO THIS PROJECT.

11.1.1 - TERO document “An Act” Legislative Act 01-14 dated February 10, 2014.
This Document is ACT AMENDING LA 30-12, "CHEROKEE NATION EMPLOYMENT RIGHTS ACT"

11.1.2 - Subcontractors are to EXCLUDE the cost for Section; Title 40, § 1011; T.
To assess an Employee Rights Fee of one-half (1/2) of one percent (1%) on all covered contracts. This cost will be paid by the Construction Manager.

11.1.3 - The Work Permits paragraph of the Tribal Employment Rights Office (TERO) Project Labor Agreement - Master Agreement LA 01-14 states: No person who is not a member of a federally recognized tribe shall be employed by a covered employer until he or she has obtained a work permit from the TERO at a cost of twenty-five dollars (\$25) per day, per permit. Subcontractors are to INCLUDE in their proposed price for the work, all costs associated with the twenty-five (\$25) per day work permit for every non-Indian individual employed on this project.

Performance and Payment Bond Requirements: (Subcontractor contracts Only)

Costs for performance and payment bonds **shall be included in your base bid and any applicable alternates or unit prices.** All exterior envelope Bid Packages (Trades) will be required to bond. In addition, all base bids, combination base Bid and including all alternates of \$100,000 or above will require Performance and Payment Bond equal to one hundred percent (100%) of the contract amount. Reference Section 00 60 04 – Exhibit B of the C.M. Bid Manual.

No obligation shall be incurred by the Owner or Foreman Manhattan Construction Team to any Bidder by reason of the issuance of these written instructions, by any notification relating to this bid, or by any act other than the execution of a written Subcontract Agreement between Foreman Manhattan Construction Team and the Bidder.

APPLICABLE SPECIFICATIONS:

DIVISION 00 – Foreman Manhattan’s Construction Manager’s Bid Manual	Complete
<u>BID PACKAGE 01 (March 6, 2018)</u>	
DIVISION 00 – Procurement Requirements and Contracting Requirements	
00 0102 – Project Information	As Applicable
00 0105 – Geotechnical Data	As Applicable
DIVISION 01 – General Requirements	As Applicable
DIVISION 03 – Concrete	
03 3000 – Cast in Place Concrete	As Applicable
DIVISION 31 – EARTHWORK	
31 2000 – Earthwork	As Applicable
31 2319 – Dewatering	As Applicable
31 2500 – Erosion and Sedimentation Control	As Applicable
31 5000 – Excavation Support and Protection	As Applicable
31 6329 – Drilled Concrete Piers and Shafts	As Applicable
DIVISION 32 – SITE IMPROVEMENTS	
32 9200 – Turf and Grasses	As Applicable
DIVISION 33 – UTILITIES	
Section 33 5100 – Private Storm Sewer	As Applicable
Legends, Notes and Schedules per Plans and Specifications	As Applicable
Geotechnical Engineering Report by Building & Earth Sciences, Inc. dated January 17, 2018	As Applicable

BID PACKAGE 02 (March 27, 2018)

DIVISION 07 – THERMAL AND MOISTURE PROTECTION

07 1300 – Sheet Waterproofing As Applicable
07 2100 – Thermal Insulation As Applicable

DIVISION 22 – PLUMBING

22 1113 – Water Distribution As Applicable
22 1313 – Private Sanitary Sewerage As Applicable
22 1316 – Sanitary Waste and Vent Piping As Applicable

DIVISION 23 – HEATING, VENTING, AND AIR CONDITIONING

23 6500 – Closed Circuit Cooling Tower COMPLETE
23 7313 – Central Station Air Handling Units COMPLETE
23 7313.1 – Central Station Air Handling Units COMPLETE

DIVISION 26 – ELECTRICAL

26 0519 – Low Voltage Electrical Power Conductors and Cables As Applicable
26 0526 – Grounding and Bonding for Electrical Systems As Applicable
26 0529 – Hangers and Supports for Electrical Systems As Applicable
26 0533 – Raceways and Boxes for Electrical Systems As Applicable
26 0543 – Underground Ducts and Raceways for Electrical Systems As Applicable
26 0544 – Sleeves and Sleeve Seals for Electrical Raceways and Cabling As Applicable
26 4113 – Lighting Protection for Structures As Applicable

DIVISION 31 – EARTHWORK

31 3116 – Termite Control As Applicable

BID PACKAGE 03 (April 16, 2018)

DIVISION 03 - CONCRETE

03 4500 PRECAST ARCHITECTURAL CONCRETE As Applicable

DIVISION 04 - MASONRY

04 4301 STONE MASONRY VENEER DIVISION As Applicable

05 - METALS

05 1200 STRUCTURAL STEEL FRAMING As Applicable
05 5150 FIXED METAL LADDERS As Applicable

DIVISION 06 - WOOD, PLASTICS, AND COMPOSITES

06 1000 ROUGH CARPENTRY As Applicable
06 1110 WOOD BLOCKING AND CURBING As Applicable

DIVISION 07 - THERMAL AND MOISTURE PROTECTION

07 1300 SHEET WATERPROOFING As Applicable
07 1310 WATER REPELLENTS As Applicable
07 2100 THERMAL INSULATION As Applicable
07 2119 FOAMED-IN-PLACE INSULATION As Applicable
07 2120 POLYISOCYANURATE INSULATION As Applicable
07 2400 EXTERIOR INSULATION AND FINISH SYSTEMS As Applicable
07 2510 FLUID APPLIED VAPOR PERMEABLE AIR BARRIER MEMBRANE As Applicable
07 4113 METAL ROOF PANELS As Applicable
07 4213 METAL WALL PANELS As Applicable
07 4600 FIBER CEMENT SIDING As Applicable
07 5200 MODIFIED BITUMINOUS MEMBRANE ROOFING As Applicable
07 6200 SHEET METAL FLASHING AND TRIM As Applicable
07 8100 APPLIED FIREPROOFING As Applicable
07 8400 FIRESTOPPING As Applicable
07 9000 JOINT SEALERS As Applicable

DIVISION 08 - OPENINGS

08 1113 HOLLOW METAL DOORS AND FRAMES As Applicable
08 3323 OVERHEAD COILING DOORS As Applicable
08 4229 AUTOMATIC ENTRANCES As Applicable
08 4233 REVOLVING DOOR ENTRANCES As Applicable
08 4300 ALUMINUM STOREFRONT ENTRANCES As Applicable
08 4310 ALUMINUM STOREFRONT WINDOW SYSTEMS As Applicable
08 4400 GLAZED ALUMINUM CURTAIN WALL SYSTEMS3 As Applicable
08 7100 DOOR HARDWARE As Applicable
08 8150 GLASS As Applicable

DIVISION 09 – FINISHES

09 2116 GYPSUM BOARD ASSEMBLIES	As Applicable
09 5100 ACOUSTICAL CEILINGS	As Applicable
09 9000 PAINTINGS AND COATINGS	As Applicable

DIVISION 10 – SPECIALTIES

10 2226 OPERABLE PARTITIONS	As Applicable
10 7500 FLAGPOLES	As Applicable
10 8200 ROOF TOP EQUIPMENT SCREENS	As Applicable

DIVISION 11 - EQUIPMENT

11 1313 LOADING DOCK BUMPERS	As Applicable
11 1316 LOADING DOCK SEALS AND SHELTERS	As Applicable
11 1319.13 LOADING DOCK LEVELERS	As Applicable

BID PACKAGE 04 (April 20, 2018)

DIVISION 32 – EXTERIOR IMPROVEMENTS

32 1216 ASPHALT PAVING	As Applicable
32 1313 CONCRETE PAVING	As Applicable
32 1373 CONCRETE PAVING JOINT SEALANTS	As Applicable
32 1723 PAVEMENT MARKINGS	As Applicable
32 3113 CHAIN LINK FENCES AND GATES	As Applicable

BID PACKAGE 05 (May 3, 2018)

DIVISION 6 –WOODS, PLASTICS AND COMPOSITES

06 2000 FINISH CARPENTRY	As Applicable
06 4100 ARCHITECTURAL WOOD CASEWORK	As Applicable
06 8300 HIGH PRESSURE DECORATIVE LAMINATES	As Applicable

DIVISION 8 –OPENINGS

08 1416 FLUSH WOOD DOORS	As Applicable
08 3100 ACCESS DOORS & PANELS	As Applicable
08 3313 COILING COUNTER DOORS	As Applicable
08 3323 OVERHEAD COILING DOORS	As Applicable

DIVISION 9 –FINISHES

09 3050 TILE	As Applicable
09 6500 RESILIENT FLOORING & BASE	As Applicable
09 6813 TILE CARPETING	As Applicable
09 6900 ACCESS FLOORING	As Applicable
09 9100 PAINTS AND COATINGS	As Applicable
09 9600 RESINOUS FLOOR COATINGS	As Applicable

DIVISION 10 –SPECIALTIES

10 2113.19 PLASTIC TOILET COMPARTMENTS	As Applicable
10 2601 WALL AND CORNER GUARDS	As Applicable
10 2615 HIGH IMPACT WALL COVERING	As Applicable
10 2800 TOILET ACCESSORIES	As Applicable
10 4400 FIRE PROTECTION SPECIALTIES	As Applicable
10 5100 LOCKERS	As Applicable

DIVISION 11 –EQUIPMENT

11 4000 FOODSERVICE EQUIPMENT	As Applicable
-------------------------------	---------------

DIVISION 22 – PLUMBING

22 05 13 COMMON MOTOR REQUIREMENTS FOR PLUMBING EQUIPMENT	COMPLETE
22 05 16 EXPANSION FITTINGS AND LOOPS FOR PLUMBING PIPING	COMPLETE
22 05 17 SLEEVES AND SLEEVE SEALS FOR PLUMBING PIPING	COMPLETE
22 05 18 ESCUTCHEONS FOR PLUMBING PIPING	COMPLETE
22 05 19 METERS AND GAGES FOR PLUMBING PIPING	COMPLETE
22 05 23 GENERAL-DUTY VALVES FOR PLUMBING PIPING	COMPLETE
22 05 29 HANGERS AND SUPPORTS FOR PLUMBING PIPING AND EQUIPMENT	COMPLETE
22 05 48 VIBRATION AND SEISMIC CONTROLS FOR PLUMBING PIPING AND EQUIPMENT	COMPLETE
22 05 53 IDENTIFICATION FOR PLUMBING PIPING AND EQUIPMENT	COMPLETE
22 07 16 PLUMBING EQUIPMENT INSULATION	COMPLETE
22 07 19 PLUMBING PIPING INSULATION	COMPLETE
22 08 00 COMMISSIONING OF PLUMBING SYSTEMS	COMPLETE
22 11 16 DOMESTIC WATER PIPING	COMPLETE
22 11 19 DOMESTIC WATER PIPING SPECIALITIES	COMPLETE

22 11 23 DOMESTIC WATER PUMPS	COMPLETE
22 13 16 SANITARY WASTE AND VENT PIPING	COMPLETE
22 13 19 SANITARY WASTE PIPING SPECIALITIES	COMPLETE
22 42 13.13 COMMERCIAL WATER CLOSETS	COMPLETE
22 42 13.16 COMMERCIAL URINALS	COMPLETE
22 42 16.13 COMMERCIAL LAVATORIES	COMPLETE
22 42 16.16 COMMERCIAL SINKS	COMPLETE
22 47 16 PRESSURE WATER COOLERS	COMPLETE
DIVISION 23 – HEATING VENTILATING AND AIR-CONDITIONING (HVAC)	
23 00 01 HVAC GENERAL REQUIREMENTS	COMPLETE
23 00 02 BASIC HVAC MATERIALS AND METHODS	COMPLETE
23 05 16 PIPE EXPANSION FITTINGS AND LOOPS	COMPLETE
23 05 18 ESCUTCHEONS FOR HVAC PIPING	COMPLETE
23 05 19 HVAC METERS AND GAGES	COMPLETE
23 05 23 VALVES	COMPLETE
23 05 29 HANGERS AND SUPPORTS	COMPLETE
23 05 48 HVAC VIBRATION CONTROLS	COMPLETE
23 05 53 MECHANICAL IDENTIFICATION	COMPLETE
23 05 93 TESTING, ADJUSTING, AND BALANCING	COMPLETE
23 07 13 DUCT INSULATION	COMPLETE
23 07 17 EQUIPMENT INSULATION	COMPLETE
23 07 19 HVAC PIPE INSULATION	COMPLETE
23 08 00 COMMISSIONING OF HVAC SYSTEMS	COMPLETE
23 09 00 AUTOMATIC TEMPERATURE CONTROL SYSTEMS	COMPLETE
23 09 93 SEQUENCE OF OPERATIONS	COMPLETE
23 21 13 HYDRONIC PIPING	COMPLETE
23 21 23 HYDRONIC PUMPS	COMPLETE
23 23 00 REFRIGERANT PIPING	COMPLETE
23 25 00 HVAC WATER TREATMENT	COMPLETE
23 31 13 HVAC DUCTS	COMPLETE
23 33 0 DUCT ACCESSORIES	COMPLETE
23 34 23 HVAC POWER VENTILATORS	COMPLETE
23 36 00 AIR TERMINAL UNITS	COMPLETE
23 37 13 DIFFUSERS, REGISTERS, AND GRILLES	COMPLETE
23 51 00 BREECHINGS, CHIMNEYS, AND STACKS	COMPLETE
23 52 16 CONDENSING BROILERS	COMPLETE
23 64 18.1 MODULAR CENTRAL PLANT	COMPLETE
23 65 00 CLOSED CIRCUIT COOLERS	COMPLETE
23 73 13 AIR-HANDLING UNIT	COMPLETE
23 73 13.1 AIR HANDLING UNIT / DEDICATED OUTDOOR AIR SYSTEM / ENERGY RECOVERY UNIT	COMPLETE
23 82 19 FAN -COIL UNITS	COMPLETE
23 82 39 UNIT HEATERS	COMPLETE
DIVISION 26 – ELECTRICAL	
26 05 19 LOW-VOLTAGE ELECTRICAL POWER CONDUCTORS AND CABLES	As Applicable
26 05 26 GROUNDING AND BONDING FOR ELECTRICAL SYSTEMS	As Applicable
26 05 29 HANGERS AND SUPPORTS FOR ELECTRICAL SYSTEMS	As Applicable
26 05 33 RACEWAYS AND BOXES FOR ELECTRICAL SYSTEMS	As Applicable
26 05 43 UNDERGROUND DUCTS AND RACEWAYS FOR ELECTRICAL SYSTEMS	As Applicable
26 05 44 SLEEVES AND SLEEVE SEALS FOR ELECTRICAL RACEWAYS AND CABLING	As Applicable
26 05 53 IDENTIFICATION FOR ELECTRICAL SYSTEMS	As Applicable
26 05 72 OVERCURRENT PROTECTIVE DEVICE SHORT-CIRCUIT STUDY	As Applicable
26 05 73 OVERCURRENT PROTECTIVE DEVICE COORDINATION STUDY	As Applicable
26 05 74 OVERCURRENT PROTECTIVE DEVICE ARC-FLASH STUDY	As Applicable
26 22 00 LOW-VOLTAGE TRANSFORMERS	As Applicable
26 24 13 SWITCHBOARDS	As Applicable
26 24 16 PANELBOARDS	As Applicable
26 27 26 WIRING DEVICES	As Applicable
26 28 13 FUSES	As Applicable
26 28 16 ENCLOSED SWITCHES AND CIRCUIT BREAKERS	As Applicable
26 29 13.03 MANUAL AND MAGNETIC MOTOR CONTROLLERS	As Applicable
26 32 13.13 DIESEL EMERGENCY ENGINE GENERATORS	As Applicable
26 33 53 STATIC UNINTERRUPTIBLE POWER SUPPLY	As Applicable

26 36 00	TRANSFER SWITCHES	As Applicable
26 41 13	LIGHTNING PROTECTION FOR STRUCTURES	As Applicable
26 51 19	LED INTERIOR LIGHTING	As Applicable
26 52 19	EMERGENCY AND EXIT LIGHTING	As Applicable
26 56 13	LIGHT POLES AND STANDARDS	As Applicable
26 56 19	LED EXTERIOR LIGHTING	As Applicable
DIVISION 28 – ELECTRONIC SAFETY AND SECURITY		
28 31 11	DIGITAL, ADDRESSABLE FIRE ALARM AND EMERGENCY COMMUNICATIONS SYSTEM	As Applicable

Terminology:

Contractor and/or Subcontractor shall mean Scope Package Bidder.

Construction Manager (CM) shall mean Foreman Manhattan Construction Team.

SCOPE OF WORK:

Includes, but is not limited to, providing all the necessary labor, materials, tools, supplies, supervision, insurance, equipment, scaffolding, hoisting, fees, etc. necessary to provide the **PLUMBING AND HVAC at the CNE Tahlequah Casino**, Tahlequah, Oklahoma in accordance with the Contract Documents. It is further understood and agreed that this Subcontract also includes the furnishing and installation of the below listed items regardless of whether or not they are in the listed specification section(s) or any other specification section(s), or shown on the plans. This scope listing is to be used as a guideline and should not be considered as an all-inclusive list of items required to provide a complete scope of work under this proposal. Drawing and detail references are provided for reference only and are not to be considered as all-inclusive of Contract Documents for the particular items referenced. **(Please note: The word “provide” when used herein shall mean furnish and install completely, including all costs for labor, materials, equipment, hoisting, layout, scaffolding, ladders, staging, tools, rigging and any other appurtenances necessary to complete the Work”.)** Subcontractor has familiarized himself with the documents and has included those items of work shown and noted on the documents and all other equipment, devices and components that are not shown or noted, but required to provide a complete, functional and working system that is in compliance with all Federal, state and local codes.

1. Provide all plumbing systems including but not limited to the following systems, complete:
 - A. Domestic water system
 - B. Storm drainage system
 - C. Sanitary sewer, waste and vent systems.
 - D. Compressed air piping systems.
 - E. All plumbing insulation.
 - F. Grease trap work
2. Provide all Plumbing Fixtures as per the Contract Documents including any specialty fixtures shown. Subcontractor shall provide all required inserts and/or embedded items.
3. Provide all templates and a sample sink of each type for cutting openings in lavatory tops and countertops.
4. Provide all plumbing and HVAC work for food service systems as described on Food Service Drawings. Include hook up of all food service equipment.
5. Provide storm sewer piping from roof sheet metal downspouts to storm sewer utility piping stubs ups in the slab (provided by Underslab Plumbing Contractor).
6. Provide all HVAC systems and equipment as per the Contract Documents, including but not limited to the following:
 - A. All refrigerant piping
 - B. All condensate drainage piping.
 - C. All supply and return Duct Work.
 - D. All exhaust air duct work and equipment.
 - E. All kitchen hoods with fire suppression systems, exhaust fans and duct work
 - F. All duct, equipment and piping Insulation.
 - G. All air handling and makeup air unit work
 - H. All computer room air conditioning and condenser unit work
 - I. All duct header work
 - J. All HVAC pumps, fans, VAV's and air devices
7. Provide all required building temperature control systems as per the Contract Documents.
8. Provide all Testing and Balancing of Mechanical and Plumbing systems as per the Contract Documents.
9. Subcontractor has included all costs for applicable Permits and Fees by the local governing authorities. Manhattan however shall pay for the General

Building Permit.

10. Provide all chemical treatment of hydronic piping as per the Contract Documents.
11. Provide all equipment warranties required by the Contract Documents. All warranties shall start at substantial completion.
12. Provide all spare parts as required by the Contract Documents.
13. Subcontractors shall thoroughly review and comply with the requirements necessary to achieve HVAC start-up and commissioning in accordance with the Contract Documents.
14. Provide all excavation, backfill, compaction and bedding materials, including rock excavation for all underground piping and structures including disposal off-site of excess materials, as required to perform the work of this Subcontract. Subcontractor must coordinate and receive approval from Foreman Manhattan's field staff for removal of any and all soils going to that site. All excavation shall be done in compliance with all safety regulations of OSHA, Manhattan Construction and Cherokee Nation regulations. Daily excavation inspection reports shall be filled out at the start of each day and turned in to Foreman Manhattan's Superintendent.
15. Provide all pumping of water in Subcontractor's excavations/trenches as required for the work of this Subcontract.
16. Provide all sleeves, blockouts, inserts, concrete coring, etc; as required to install and support the mechanical and plumbing work provided under this Subcontract,
18. Provide all miscellaneous metal and steel items for support of plumbing and mechanical work, including hangers, pedestals, protective appurtances, platforms, plates, sleeves, embedded items, unistrut, bolts, rods and straps. All embedded items such as sleeves, thimbles, inserts, anchor bolts and steel plates required to complete the mechanical and plumbing installation are also included. These steel and misc. metal items will be shop painted or galvanized in accordance with the Contract Documents.
19. Provide all cutting and patching of concrete, drywall and masonry if Subcontractor's work is not installed ahead of the other trades. All costs to patch this work from other trades will be borne by this Subcontractor.
20. Provide all fire stops, fire seals, shielding, sealants and waterproofing work as necessary for all penetrations (both horizontal and vertical) associated with the work of this Subcontract. This includes, but is not limited to, sanitary caulking of all plumbing fixtures and mechanical wall and floor penetrations.
21. Furnish and locate all access panels for walls, ceilings and floors, as required for accessing mechanical and plumbing systems. These panels shall be UL listed and labeled as required, depending on the installation location. Panels in drywall walls, acoustical and drywall ceilings will be installed by others. Subcontractor shall coordinate location of these access panels with Manhattan and other trades.
22. Subcontractor shall help coordinate their work that goes above the ceilings with other above ceiling subcontractors. Per the Authority Having Jurisdiction (AHJ), no fire suppression piping and/or hangers can touch any other surrounding above ceiling materials (with no exception); therefore it is this Subcontractor's responsibility to install their products in an approved method to avoid other above ceiling materials. Noncompliance with this requirement will result in the Subcontractor reinstalling their product in accordance with this requirement. Subcontractor agrees to attend all above ceiling coordination meetings as required by Project field staff.
23. Coordinate with the Owner's Inspection Authority for all inspection required for the completion of this Subcontract work. Subcontractor understands that all inspection must be scheduled with Foreman Manhattan personal at least seventy-two (72) hours in advance.
24. Provide all roof curbs, supports, flashings, flashing collars, water seals, escutcheons, and counter flashings as required for all mechanical and plumbing roof penetrations.
25. Provide all vibration isolation as required for the work of this Subcontract and in accordance with the Contract Documents.
26. Provide all sound attenuation and duct attenuation as required by the Contract Documents.
27. Provide all plywood, wood blocking or metal backing required for proper installation of systems provided under the work of this Subcontract.
28. Provide labels, color coding, stencils, tags, warning tape and similar pipe identifications relative to the scope of this Subcontract and in accordance with the Contract documents.
29. Provide all factory-applied prime and factory-applied painting of equipment, motors, and other apparatus as specified. Also provide touch-up painting of pre-finished items as needed. Surfaces that will receive a field applied paint finish by others shall be left clean and debris removed ready for finish coats.

30. Provide all motor starters and VFD's for mechanical equipment in accordance with the Contract Documents.
31. Provide all fire dampers, smoke dampers, and combination fire/smoke dampers as required by the Contract Documents and all applicable building codes.
32. Provide installation of fire alarm smoke detectors located in ductwork. (Detectors provided by electrical subcontractor)
33. Provide a complete Building Temperature Control System as specified. This includes all conduit, control wiring, panels, control devices, valves, computers, all software, and training for a complete and functional system.
34. Provide all grouting of equipment and supports relative to the scope of this Subcontract.
35. This Subcontract includes plumbing service and final connections for all equipment specified in other specification sections which require plumbing services
36. This Subcontract shall install and make all necessary piping connections to all Owner furnished equipment as indicated on the Contract Documents.
37. TEMPORARY WORK, GENERAL REQUIREMENTS: Subcontractor includes the furnishing, installation, maintenance, and removal of a complete Temporary Mechanical system as described below:
 - A. Subcontractor agrees to make every effort to complete the permanent building heating, cooling, dehumidification and ventilation systems at the earliest possible date so that the permanent system can be used for temporary cooling, dehumidification, heating and ventilation purposes, prior to final completion of the buildings. Subcontractor agrees to furnish and install and maintain temporary filters and water treatment chemicals. He shall also provide the necessary operation/manpower required by the mechanical trades to use the permanent system on a temporary basis.
 - B. It is understood that Foreman Manhattan will obtain approval from Owner prior to allowing Subcontractor to operate the temporary heating and ventilating systems. Subcontractor shall maintain equipment during this temporary basis. Upon final acceptance of the systems by the Owner, this Subcontractor shall replace the temporary filters and water treatment chemicals with permanent materials, and extend all related warranties so they continue from the date of final acceptance to full period of time stated in the Contract Documents.
 - C. Subcontractor agrees to expedite completion of the permanent water lines within the building so that water for construction purposes is available at the earliest possible time.
 - D. Subcontractor agrees to expedite completion of the permanent sanitary sewer lines within the building so that temporary sanitary facilities can be installed at the earliest possible time. A minimum agreed upon number of temporary toilets will be installed by this Subcontractor and replaced at end of the job with the permanent toilets.
 - E. Subcontractor agrees to expedite completion of the roof drains and permanent storm water system within the buildings so that rain water can be removed from these roofs, which may necessitate some reworking of drains during the roofing operation.
37. Coordinate with the Owner's Testing Lab and Owner's Inspection Authority with all required testing and inspections, including assisting lab technician and/or inspectors in accessing areas of the project as needed. Initial testing fees will be paid by the Owner, testing fees and removal of failed materials associated with failed test reports will be paid by this Subcontractor. Subcontractor understands that all inspections/testing must be scheduled with Foreman Manhattan personal at least seventy-two (72) hours in advance.
38. Subcontractor shall abide by the Licensing and certification requirements of the State of Oklahoma and the Cherokee Nation.
39. This contractor shall receive, unload, protect as needed, take possession of and install Mechanical Equipment provided by Airtech. The purchase of this equipment shall be EXCLUDED from this Bid Package 23.01. This contractor shall transfer ownership and warranty of this equipment. See attached list of equipment for reference.
40. Provide one (1) year standard labor warranty for the Airtech Equipment, and six (6) months of additional warranty for equipment and labor for start up and use of the Airtech equipment during construction.

GENERAL ITEMS

1. Include separate mobilizations / demobilizations as required by the Project Schedule and Phasing Plans.
2. Provide all shop drawings, product data, sample and other pertinent submittals for the work of this Subcontract. Provide engineering and printing costs for all shop drawings, coordination drawings, and product submittals for architect approval as required to properly coordinate the work included in this Subcontract with other trades. Include costs for revising and resubmitting shop/ coordination drawings as needed.
3. Subcontractor will assist Foreman Manhattan with providing material quantities and cost breakdowns as required for the Owner's and Foreman Manhattan's budget requirements. All breakouts specified in this subcontract will be used for accounting purposes and tracking only.
4. Contractor shall provide a complete installation that complies with all applicable codes, ordinances and satisfying all Authorities Having Jurisdiction.
5. Provide all field engineering and layout from benchmarks and base building control (benchmarks and baseline control is furnished by others). This Subcontractor is responsible for replacement of any damaged benchmarks, base line control or layout work of other trades/packages damaged or destroyed by the work of this work package.

6. Provide all required pedestrian protection, traffic control and protection including flagman, barricades, signage, etc. as required for the work, and as may be required for protection for equipment access, deliveries and loading.
7. Subcontractor is required to comply with requirements to control Dust and Airborne Contaminants. No waste materials or debris shall be allowed to accumulate.
8. Provide coordination, assistance, and necessary access for the Owner's furnished Testing Laboratory, including notification, obtaining samples and data gathering as required for scope of work. Costs for retesting due to failed tests and/or for Subcontractor's unpreparedness, will be paid by this Subcontractor.
9. It is mutually understood and agreed that this subcontractor will coordinate all of the scheduled deliveries of these items being furnished by others with the Foreman Manhattan designated representative. This includes the on or off site storage, staging, inventory control, and shipping to the site. All damages or shortages are to be reported within 24 hours of delivery.
10. Subcontractor agrees to be bound by the Welcome Package issued by the Foreman Manhattan Field staff.
11. **Revise paragraph 1.2.3 of section 00 60 02A Manhattan General Provisions as contained in the Construction Manager's Bid manual as follows:**
Until Subcontractor's obligations under this Subcontract are completely fulfilled, Subcontractor agrees not to perform any changes to the work directly for Owner or any of its tenants, or deal directly with Owner's representatives with respect to the work and/or changes to the work, in connection with the Project, unless approved in writing by Foreman Manhattan. Foreman Manhattan understands that the Owner and specifically TERO shall communicate directly with the subcontractor to maintain a spirit of cooperation and also to utilize the TERO Job Bank to the fullest extent giving first hire priority rights to Cherokee Citizens.
12. **The Owner requirements for funding for work in progress is to provide payment less retainage of ten percent (10%), which shall be withheld and paid, without interest, upon final completion of the entire project.**
13. The terms and conditions contained in the following documents including General Provisions, Article 2.5, "Indemnification" as included within the contract documents; are incorporated herein by reference as if fully written out;
 - Foreman Manhattan General Provisions 2012
 - Exhibit A – (Scope of Work)
 - Exhibit B – (Bond Forms)
 - Exhibit C – (Insurance Requirements / Sample)
 - Exhibit D – (Contract Documents)
 - Exhibit E – (Special Conditions)
 - Exhibit F – (Project Schedule)
 - Exhibit G – Tax Exempt – O.D.P.I.
 - Exhibit H – (Foreman Manhattan Additional Safety Requirements)

SCOPE OF WORK EXCLUSIONS:

The following items are excluded from this Subcontract:

1. Fire Protection
2. Electrical Power.
3. Fire Alarm.
4. Site utility services up to +/- 5'-0" outside of building line unless otherwise included.
5. Poured in place concrete housekeeping pads
6. Cost of Dumpsters
7. Purchase only of Mechanical Equipment provided by Airtech. Install shall be INCLUDED in this Bid Package 23.01.
8. Underslab PVC Carbonated Beverage Lines (Provided by separate Underslab Plumbing Contract)
9. Underslab PVC duct for beer lines, carbonated beverage lines, as shown on the Food Service Drawings (Provided by separate Underslab Plumbing Contractor)
10. Primary Gas Service Line and Gas Meter.

Value Analysis Suggestions:

Please write in the box below any suggestions for cost savings / value analysis which were discovered during the course of bidding this project, along with a dollar value for each item. VA Suggestions may be included in the criteria considered for successful subcontractor selection. Attach additional sheet(s) if necessary.

1. < \$ _____ > Savings
Description:

2. < \$ _____ > Savings
Description:

3. < \$ _____ > Savings
Description:

4. < \$ _____ > Savings
Description:

5. < \$ _____ > Savings
Description:



AIRETECH CORPORATION

7636 E. 46th Place
Tulsa, OK 74145

(918)665-6600
fax (918)627-7004

airetechcorp.com

JOB: CNE Tahlequah - Packaged RTU WSHP
Revision #1
Tahlequah OK

Date: 4/26/2018

Quote #: 6847

TO: PAT FOGARTY
Foreman-Manhattan
FAX:

Total:

11 Annexair packaged rooftop WSHP (RTU-1 thru 10, and MAU-1) per the attached specification and attached schedule dated 4-24-18 provided to MSA including:

- (9) rooftop units with RA/OA configuration with 100% airside economizers
- (2) RTU's are 100% OSA with packaged AHRI 1060 certified enthalpy wheels, wheels are Annexair standard silica gel wheels
- Enthalpy wheels have VFD frost control system, speed controlled by BAS.
- 2" MERV 8 prefilters installed on entering side of wheels in both air tunnels
- All units have packaged water source heat pump design
- All units have modulating hot gas reheat for dehumidification
- Thermocomposite units with minimum 30% recycled material, 2" double wall panels
- Direct drive plug fans with ABB ACH550 VFDs to maintain owner VFD standard requirements
- All units shipped in one piece
- Factory mounted controllers with BACnet interface
- Variable speed control scroll compressors
- Service lights and GFI service outlets, 120V power separate by others, separate from main unit power.
- Flat roof curbs included
- Factory start-up, time included for temp start up and final start up
- 1 year parts warranty entire unit
- 5 year compressor parts warranty
- 5 year parts warranty on wheel media an bearings
- Travel costs included for factory inspection by 2 representatives of owner choosing before shipment
- Freight included

Accepted By: _____

PO #: _____

Date: _____

Company: _____

Submittal copies: _____

ALL QUOTATIONS & SALES ARE MADE IN ACCORDANCE WITH THE FOLLOWING TERMS AND CONDITIONS:

All quotations are valid for 30 days.
Sales taxes are not included in th is quotation.

Terms are Net 30 days from date of invoice.
Our pricing is based on standard lead times from the factory. Any expedited orders may incur additional charges.

All quotations are FOB factory, full freight allowed, unless otherwise noted.



AIRETECH CORPORATION

7636 E. 46th Place
Tulsa, OK 74145

(918)665-6600
fax (918)627-7004

airetechcorp.com

JOB: CNE Tahlequah - Packaged RTU WSHP
Revision #1
Tahlequah OK

Date: 4/26/2018

Quote #: 6847

TO: PAT FOGARTY
Foreman-Manhattan
FAX:

Total:

Standard lead time is 18 to 22 weeks ARO

Net price add for spare parts from Annexair including the following:

- spare compressor of each size
- spare controller
- spare control boards
- spare fan motor of each size
- spare EZ balancer control module
- spare VFD for each size fan motor



Thank You,

Chad Smith

Accepted By: _____

PO #: _____

Date: _____

Company: _____

Submittal copies: _____

ALL QUOTATIONS & SALES ARE MADE IN ACCORDANCE WITH THE FOLLOWING TERMS AND CONDITIONS:

All quotations are valid for 30 days.
Sales taxes are not included in this quotation.

Terms are Net 30 days from date of invoice.
Our pricing is based on standard lead times from the factory. Any expedited orders may incur additional charges.

All quotations are FOB factory, full freight allowed, unless otherwise noted.

PRELIMINARY DATA

19571 - CNE Tehlequah

Prepared for:
Chad Smith



Date:	April 30, 2018	Page(s):	19	including this one
Revision:	7	Prepared by:	Fares Jandali Rifai	

Qty	Model	Tag	Dimensions (L X W X H)	Weight (LBS)
1	AHU-E-12-D-HR-WZ46	AHU-1	270" x 102" x 72"	7400
2	AHU-E-25-D-HR-WZ96	AHU-2/AHU-3	378" x 102" x 108"	12300
1	AHU-E-16-D-HR-WZ60	AHU-4	287" x 93" x 102"	8400
2	AHU-E-16-D-HR-WZ60	AHU-5/AHU-8	287" x 93" x 102"	8400
2	ERP-E-25-EW-D-HR-2XWZ52	AHU-6/AHU-7	396" x 130" x 137"	18600
1	AHU-E-05-D-HR-WZ24	AHU-9	258" x 63" x 72"	3700
1	AHU-E-09-D-HR-WZ30	AHU-10	294" x 78" x 90"	6300
1	MAU-E-16-D-HR-WZ96	MAU-1	210" x 117" x 102"	9800
1	MAU-E-07-D-HR-WZ52	MAU-2	138" x 105" x 99"	5300

LEED - As a company entirely devoted to promote energy savings, Annexair can provide you with smart air solutions to help you achieve your LEED objectives. By doing so, you can add up to 10 points to your LEED project depending on the application.

ENVIRONMENTAL ISSUES - Bringing innovative and simple ideas into our product is our way to embrace LEED concepts for your benefits. This is our main goal. To achieve this, Annexair incorporates the following concept in it's production:

Project Name: CNE Tehlequah

Project Number: 19571

2018-04-26 14:13



VARIABLE SPEED WATER SOURCE HEAT PUMP SELECTION

Tag	AHU-1	AHU-2/AHU-3	AHU-4	AHU-5/AHU-8	AHU-6/AHU-7	AHU-9	AHU-10	MAU-1	MAU-2
Altitude (ft)	0								
	<u>COOLING DESIGN</u>								
CFM	13000	24000	15000	16000	25000	6000	8000	15500	8000
Entering Dry Bulb/Wet Bulb (°F/°F)	78.5 / 65.32	83.7 / 68.7	83.7 / 68.7	81.5 / 67.3	82 / 68.8	81.5 / 67.3	81.6 / 67.3	101 / 78	101 / 78
Enthalpy Entering (btu/lb)	30.1	32.8	32.8	31.7	32.9	31.7	31.7	41.2	41.2
Leaving Dry Bulb/Wet Bulb (°F/°F)	52 / 52	52/52	52/52	52/52	52/52	52/52	52/52	65/65	65/65
Enthalpy Leaving (btu/lb)	21.4	21.4	21.4	21.4	21.4	21.4	21.4	30.0	30.0
Capacity Required (MBH)	512	1232	770	741	1294	278	371	784	405
EWT (°F)	85	85	85	85	85	85	85	85	85
GLYCOL	None	None	None	None	None	None	None	None	None
Model	WZ-46	WZ-96	WZ-60	WZ-60	WZ-52	WZ-24	WZ-30	WZ-96	WZ-52
Qty	1	1	1	1	2	1	1	1	1
Number of Compressors	2	6	4	4	4	2	2	6	4

COOLING PERFORMANCE

Condensing Temperature (°F)	115	115	115	115	115	115	115	115	115
Evaporating Temperature (°F)	38.0	45.8	42.4	40.4	40.5	40.8	40.5	38.0	38.0
Actual Cooling Capacity (MBH)	523	1232	770	741	1294	278	371	1061	617
Compressor Consumption (WATTS)	44385	91625	61421	61630	108548	23447	30811	92831	54504
Condenser Heat of Rejection (MBH)	674	1545	980	951	1664	358	476	1377	803
Leaving Water Temperature (°F)	101.9	100.4	100.7	100.2	103.5	99.3	100.9	98.8	101.1
Min / Max Entering Water Temperature (°F)	75/85	75/85	75/85	75/85	75/85	75/85	75/85	75/85	75/85
Hot Gas Reheat	Yes	Yes	Yes	Yes	Yes	Yes	Yes	Yes	Yes
Maximum HGR coil capacity (MBH)	539	1236	784	761	1332	286	381	1102	642

HEATING DESIGN

CFM	13000	24000	15000	16000	25000	6000	8000	15500	8000
Entering Dry Bulb (°F)	47.7	44.4	44	39.6	47.8	50.6	54.4	0	0
Required Leaving Dry Bulb (°F)	94	93	75	88	93	75	75	75	75
Capacity Required (MBH)	507	1260	503	837	1221	159	178	1256	648
EWT (°F)	60	60	60	60	60	60	60	60	60
GLYCOL	None	None	None	None	None	None	None	None	None

HEATING PERFORMANCE

Condensing Temperature (°F)	104	103	85	98	103	85	85	85	85
Evaporating Temperature (°F)	19.9	29.8	0.0	28.9	17.8	0.0	0.0	27.5	20.0
Actual Water Cooling Capacity (MBH)	388	982	381	662	888	142	190	1033	516
Compressor Consumption (WATTS)	39113	81560	44740	51213	97423	17032	22370	65310	38765
Actual Heating Capacity (MBH)	521	1260	533	837	1221	200	267	1256	648
Leaving Water Temperature (°F)	50.3	50.2	53.9	49.4	50.1	54.3	53.7	49.7	49.7
Min / Max Entering Water Temperature	60/80	60/80	60/80	60/80	60/80	60/80	60/80	60/80	60/80

GENERAL

GPM	80	200	125	125	180	50	60	200	100
Water Pressure Drop (FT H2O)*	15	23	21	21	17	19	19	23	20
(Qty.) Fluid Connection Diameter	(2) 2.5"	(6) 2.5"	(4) 2.5"	(4) 2.5"	(2x) (4) 2.5"	(2) 2.5"	(2) 2.5"	(6) 2.5"	(4) 2.5"
Head Pressure Control (HPC) Valves	Included / Factory Installed by Annexair	Included / Factory Installed by Annexair	Included / Factory Installed by Annexair	Included / Factory Installed by Annexair	Included / Factory Installed by Annexair	Included / Factory Installed by Annexair	Included / Factory Installed by Annexair	Included / Factory Installed by Annexair	Included / Factory Installed by Annexair
TURN DOWN (% OF TOTAL CAPACITY)	14.00%	9.33%	14.00%	14.00%	16.00%	14.00%	14.00%	9.33%	16.00%
Number of Circuits	2	3	2	2	(2x) 2	1	2	3	2
Refrigerant Charge (lbs)	92	192	128	128	104	48	64	192	104
Voltage	460	460	460	460	460	460	460	460	460
FLA of the Largest Compressor @460	33.5	23	23	23	23	17.8	23	23	23
FLA of the Balance of Components @460	33.5	115	69	69	140.2	17.8	23	115	58.6

*Water Pressure Drop includes coaxial coil and water flow valve

HEAT WHEEL PERFORMANCE



Project name CNE Tehlequah
Reference 19571
Unit tag AHU-6/-7

Date 3/1/2018

v 1.0

SUMMER

OUTSIDE AIR

Outside air Volume CFM 26316
 Summer Outside air DB **101.0**
 Summer Outside air WB **78.0**
 Grains 108.4
 Summer Outside air enthalpy 41.3
 Outside Air S.P. -0.50

EXHAUST AIR

Exhaust Volume CFM 26316
 Summer Exhaust air DB **93.9**
 Summer Exhaust air WB **73.3**
 Grains 90.8
 Summer Exhaust enthalpy 36.8
 Exhaust Air S.P. -2.57

Purge & Leak CFM 1316

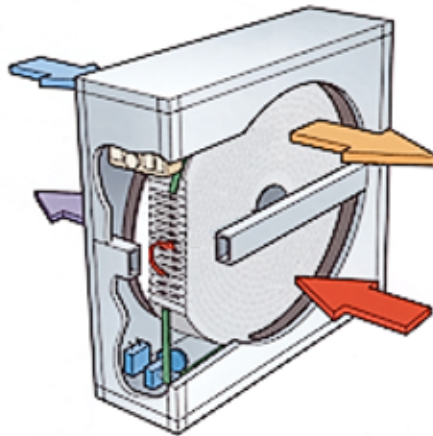

25000
 82.1
 68.8
 84.7
 32.9
 -1.27

SUPPLY AIR

Supply Volume CFM
 Summer Supply air DB.
 Summer Supply air WB.
 Grains
 Summer Supply air enthalpy
 Supply Air S.P.

RETURN AIR

Return Volume CFM
 Summer Return air DB.
 Summer Return air WB.
 Grains
 Summer Return air Enthalpy
 Return Air S.P.

25000
75.0
63.0
 67.0
 28.4
 -1.80

WINTER

OUTSIDE AIR

Outside air Volume CFM 26316
 Winter Outside air DB **0.0**
 Winter Outside air WB **-0.0**
 Grains 5.5
 Winter Outside air enthalpy 0.9
 Outside Air S.P. -0.50

EXHAUST AIR*

Exhaust Volume CFM 26316
 Winter Exhaust air DB 22.2 (17.9)
 Winter Exhaust air WB 22.2 (17.9)
 Grains 16.7 (15.3)
 Winter Exhaust enthalpy 8.0 (6.5)
 Exhaust Air S.P. -2.57

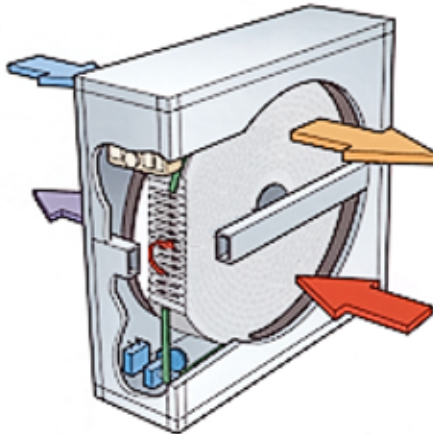

25000
 47.8 (52.1)
 39.6 (41.9)
 22.9 (22.9)
 15.0 (16.0)
 -1.27

SUPPLY AIR*

Supply Volume CFM
 Winter Supply air DB
 Winter Supply air WB
 Grains
 Winter Supply air enthalpy
 Supply Air S.P.

RETURN AIR

Return Volume CFM
 Winter Return air DB.
 Winter Return air WB.
 Grains
 Winter Return air Enthalpy
 Return Air S.P.

25000
70.0
53.0
 32.7
 21.9
 -1.80

* Actual conditions in frost control. Data in () are without frost control

GENERAL DATA

Wheel Size	25	Total	Sensible
Wheel Type	Enthalpy	Saving summer, TON	78.64
Total Effectiveness	72.0 %	Saving winter, MBH	1290.06
Pressure Drop Through the Wheel	Face velocity (FPM)	Wheel RPM	Drive
Supply side in w.g.	0.77 742	Normal 20	VFD
Exhaust side in w.g.	0.77 742	Minimum 5	Frost Control Required

Ratings have been tested in accordance to ASHRAE 84 and ARI 1060

THERMO-COMPOSITE UNIT

- 1 - 2" CASING
- 2 - OA HOOD (Qty2) w/ 4" LOUVER w/ OA DAMPER
- 3 - MIXING / RECIRCULATION DAMPER
- 4 - 2" MERV10 FILTERS
- 5 - DUAL MODE COIL
- 6 - HOT GAS REHEAT COIL
- 7 - SA DDF (Qty2) ER56C w/ 7.5HP each
- 8 - EA DDF (Qty2) GR50C w/ 5HP each
- 9 - EA DAMPER w/ 2" LOUVER
- 10 - WSHP WZ46

TAG: AHU-1		REV 2
DWG. : S-19571		BY (FJR)
MODEL : AHU-E-12-D-HR-WZ46		MEP
DATE : 04/04/2018		
WEIGHT :		

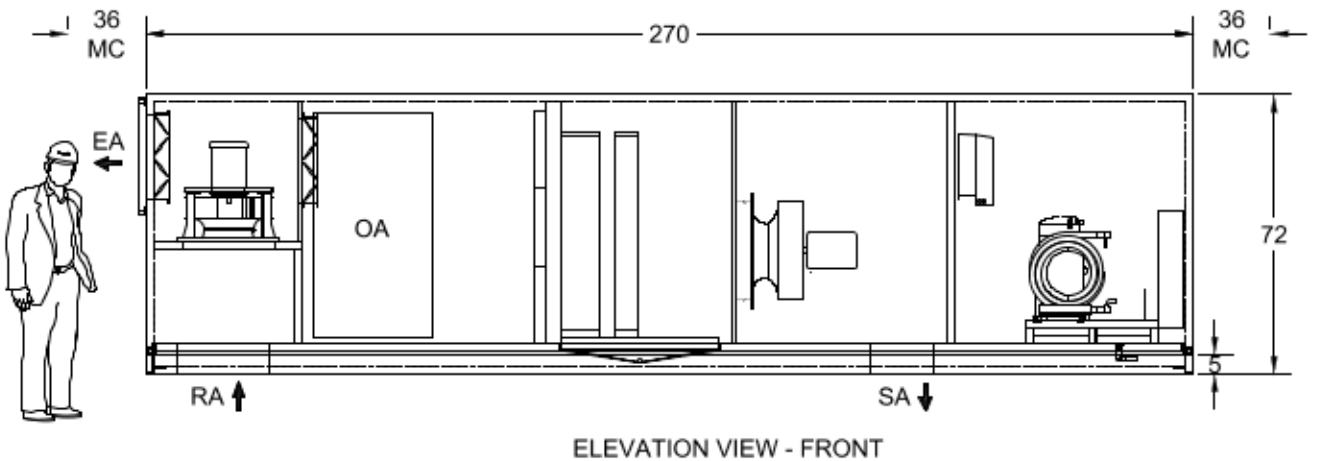
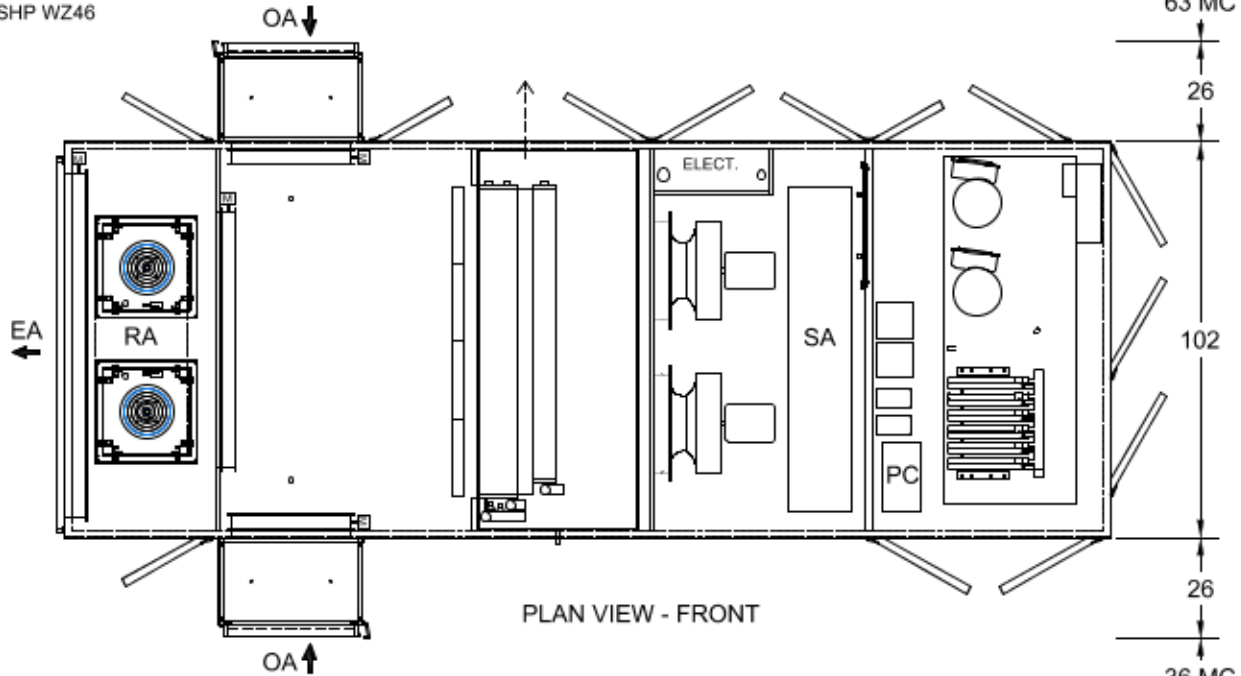

OA : OUTDOOR AIR
 SA : SUPPLY AIR
 RA : RETURN AIR
 EA : EXHAUST AIR
 Φ : GFI
 ⚡ : LIGHT
 ⚡ : LIGHT
 \$: LIGHT SWITCH
 MC : MIN. CLEARANCE

THIS DRAWING IS FOR PRELIMINARY PURPOSE ONLY, ANNEXAIR RESERVED THE RIGHT TO CHANGE DESIGN AND COMPONENTS WITHOUT NOTICE. ONLY AT THE SUBMITTAL STAGE DIMENSIONS & WEIGHT WILL BE CONFIRMED FOR FACTORY: DMC: 50"H x 79"L / 27.43sa - HGRC: 50"H x 75"L / 26.04sa



ROOF CURB
FOR REFERENCE ONLY - BY OTHERS

TAG: AHU-1	REV 2
DWG. : S-19571	BY (FJR)
MODEL : AHU-E-12-D-HR-WZ46	MEP
DATE : 04/04/2018	
WEIGHT :	

CE: CONTROLS ENTRANCE
PE: POWER ENTRACNE
PC: PIPE CHASE

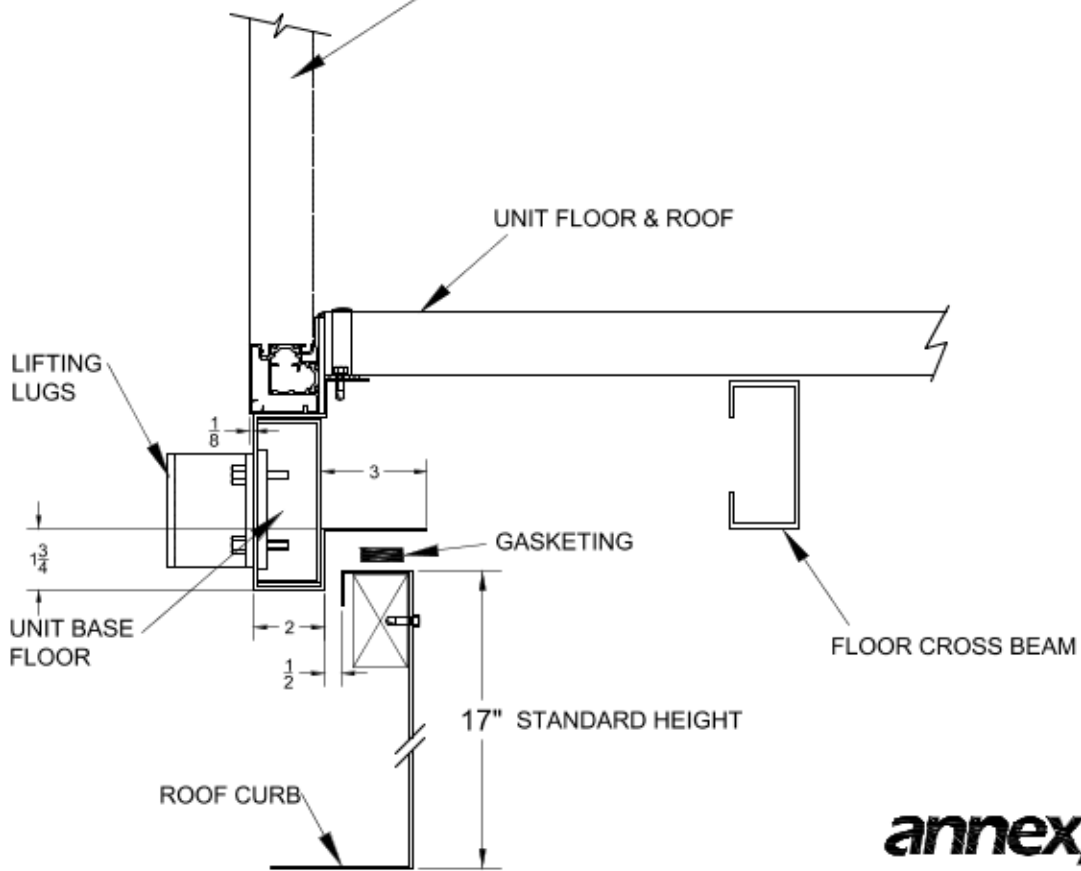
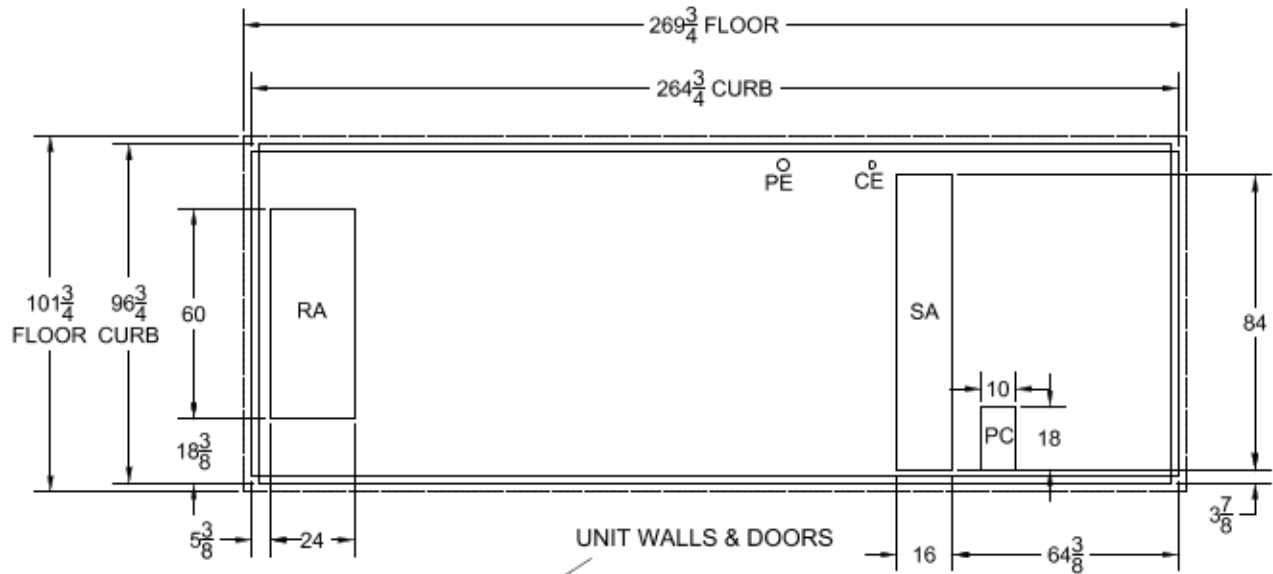

OA : OUTDOOR AIR
SA : SUPPLY AIR
RA : RETURN AIR
EA : EXHAUST AIR
Φ : EXHAUST AIR
Φ : GFI
⚡ : LIGHT SWITCH
⚡ : LIGHT
\$: LIGHT SWITCH
MC : MIN. CLEARANCE



THERMO-COMPOSITE UNIT

- 1 - 2" CASING
- 2 - OA HOOD (Qty2) w/ 4" LOUVER w/ OA DAMPER
- 3 - MIXING / RECIRCULATION DAMPER
- 4 - 2" MERV10 FILTERS
- 5 - DUAL MODE COIL
- 6 - HOT GAS REHEAT COIL
- 7 - SA DDF (Qty4) ER56C w/ 7.5HP each
- 8 - EA DDF (Qty4) GR50C w/ 5HP each
- 9 - EA DAMPER w/ 2" LOUVER
- 10 - WSHP WZ96

TAG:	AHU-2	REV	3
DWG. :	S-19571	BY	(FJR)
MODEL :	AHU-E-25-D-HR-WZ96	MEP	
DATE :	04/30/2018		
WEIGHT :			

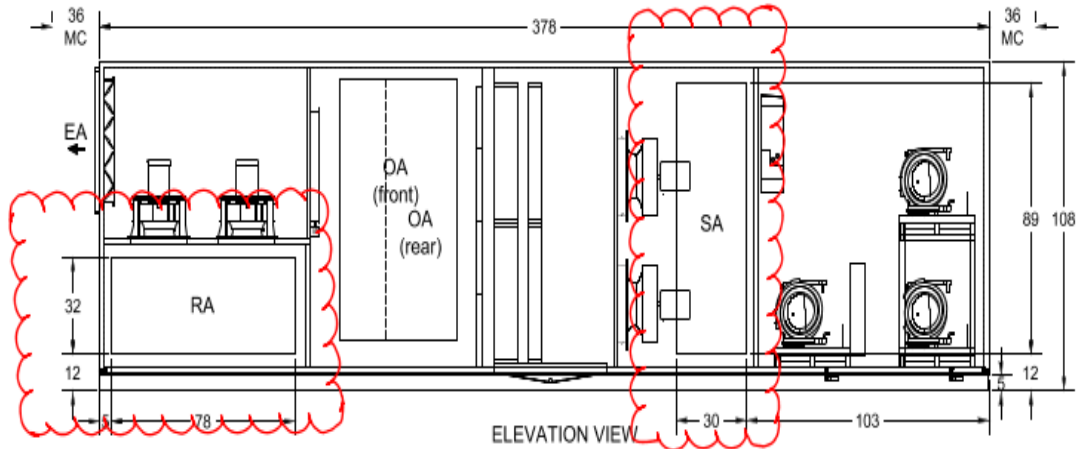
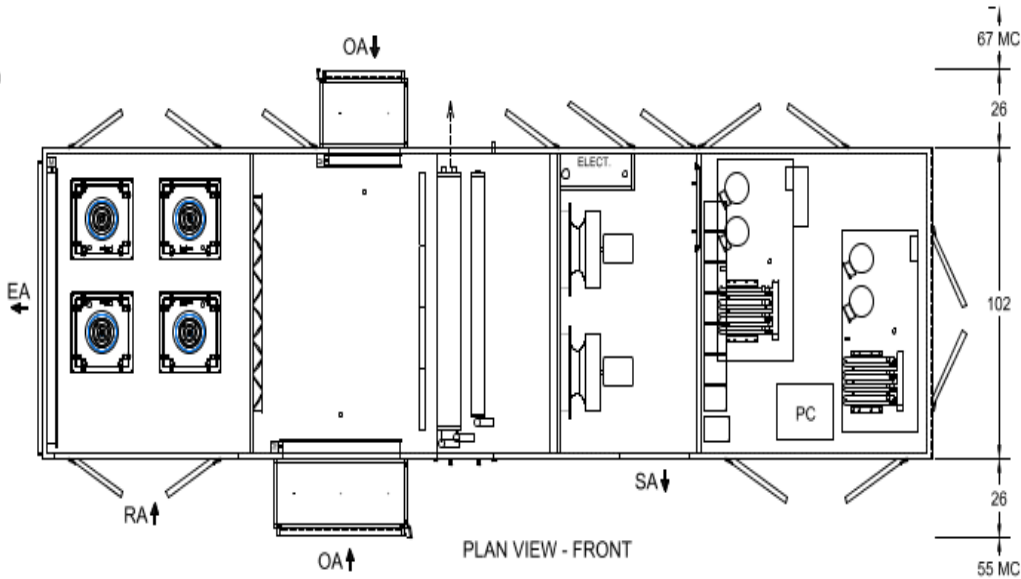

THIS DRAWING IS FOR PRELIMINARY PURPOSE ONLY, ANNEXAIR RESERVED THE RIGHT TO CHANGE DESIGN AND COMPONENTS WITHOUT NOTICE. ONLY AT THE SUBMITTAL STAGE DIMENSIONS & WEIGHT WILL BE CONFIRMED
 FOR FACTORY: DMC: (2) 44H x 82L / 50.11sa - HGRC: (2) 44H x 78L / 47.66sa



OA : OUTDOOR AIR SA : SUPPLY AIR RA : RETURN AIR EA : EXHAUST AIR CF1 LIGHT LIGHT SWITCH MC : MIN CLEARANCE

ROOF CURB
FOR REFERENCE ONLY - BY OTHERS

TAG:	AHU-2	REV	3
DWG. :	S-19571	BY	(FJR)
MODEL :	AHU-E-25-D-HR-WZ96	MEP	
DATE :	04/30/2018		
WEIGHT :			

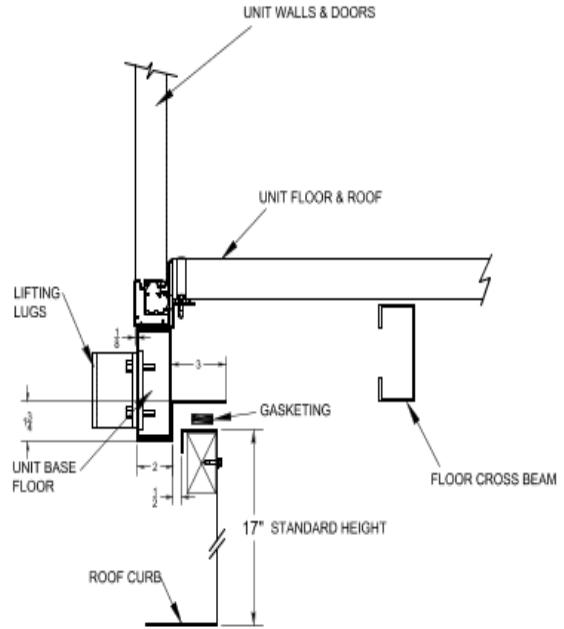
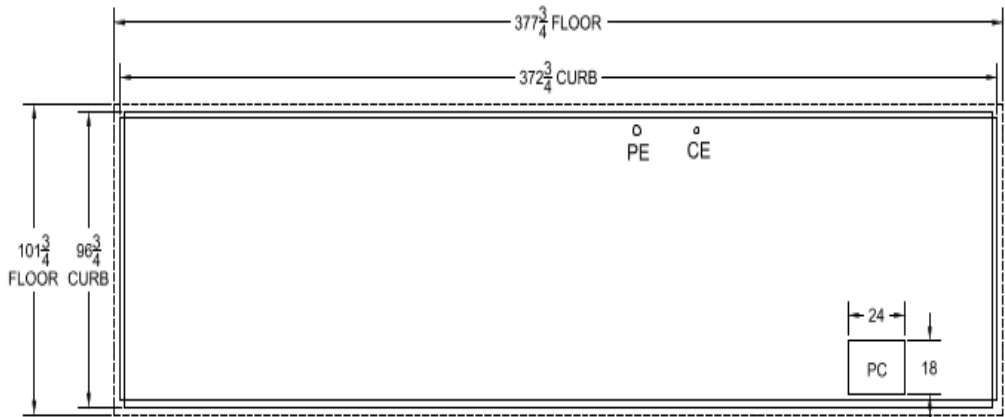

CE: CONTROLS ENTRANCE
PE: POWER ENTRANCE
PC: PIPE CHASE



OA : OUTDOOR AIR
SA : SUPPLY AIR
RA : RETURN AIR
EA : EXHAUST AIR
CFI : CFI
LIGHT : LIGHT
LIGHT SWITCH : LIGHT SWITCH
MC : MIN CLEARANCE

THERMO-COMPOSITE UNIT

- 1 - 2" CASING
- 2 - OA HOOD (Qty2) w/ 4" LOUVER w/ OA DAMPER
- 3 - MIXING / RECIRCULATION DAMPER
- 4 - 2" MERV10 FILTERS
- 5 - DUAL MODE COIL
- 6 - HOT GAS REHEAT COIL
- 7 - SA DDF (Qty4) ER56C w/ 7.5HP each
- 8 - EA DDF (Qty4) GR50C w/ 5HP each
- 9 - EA DAMPER w/ 2" LOUVER
- 10 - WSHP WZ96

TAG:	AHU-3	REV	3
DWG. :	S-19571	BY	(FJR)
MODEL :	AHU-E-25-D-HR-WZ96	MEP	
DATE :	04/30/2018		
WEIGHT :			

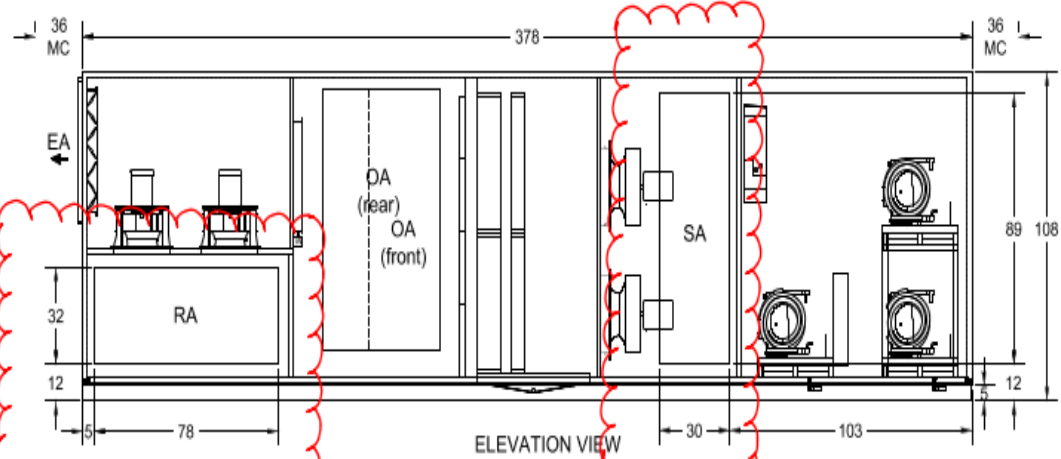
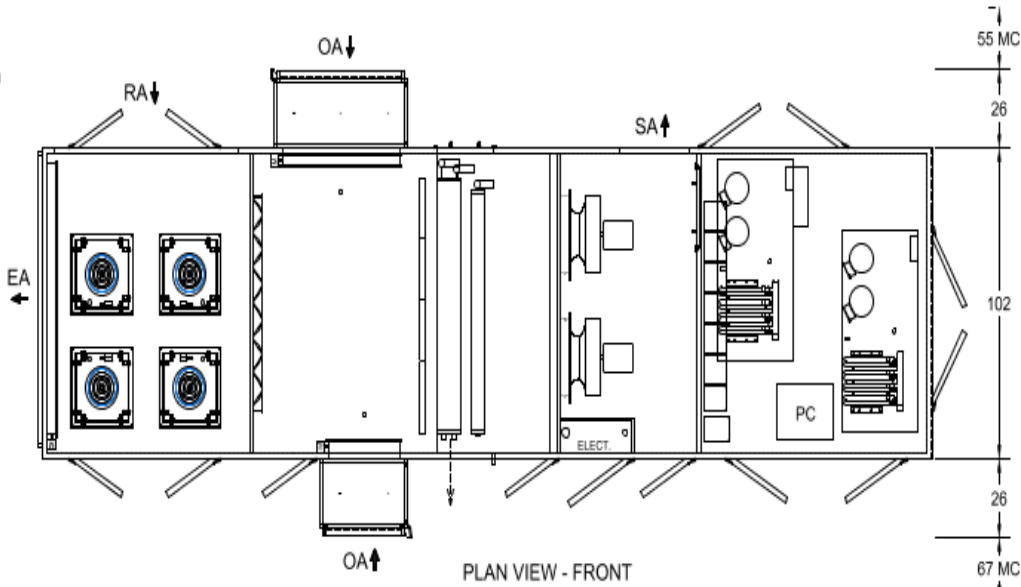

THIS DRAWING IS FOR PRELIMINARY PURPOSE ONLY. ANNEX AIR RESERVED THE RIGHT TO CHANGE DESIGN AND COMPONENTS WITHOUT NOTICE. ONLY AT THE SUBMITTAL STAGE DIMENSIONS & WEIGHT WILL BE CONFIRMED
 FOR FACTORY: DMC: (2) 44H x 82L / 50.11sa - HGRC: (2) 44H x 78L / 47.66sa



OA : OUTDOOR AIR SA : SUPPLY AIR RA : RETURN AIR EA : EXHAUST AIR CF1 LIGHT LIGHT SWITCH MC : MIN CLEARANCE

ROOF CURB
FOR REFERENCE ONLY - BY OTHERS

TAG:	AHU-3	REV	3
DWG. :	S-19571	BY	(FJR)
MODEL :	AHU-E-25-D-HR-WZ96	MEP	
DATE :	04/30/2018		
WEIGHT :			

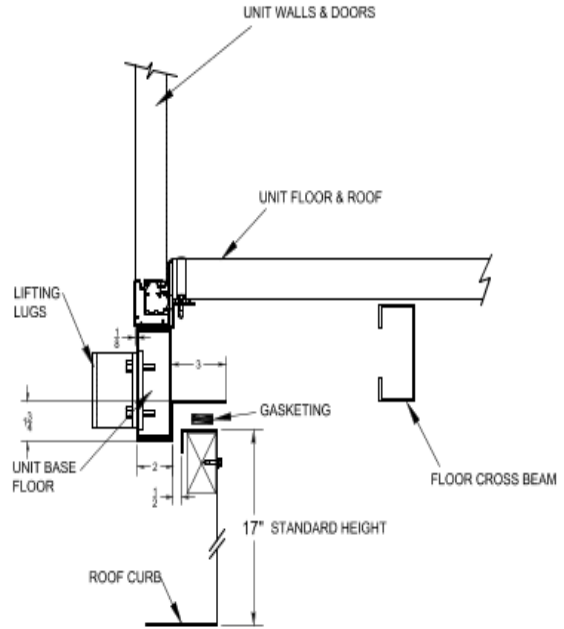
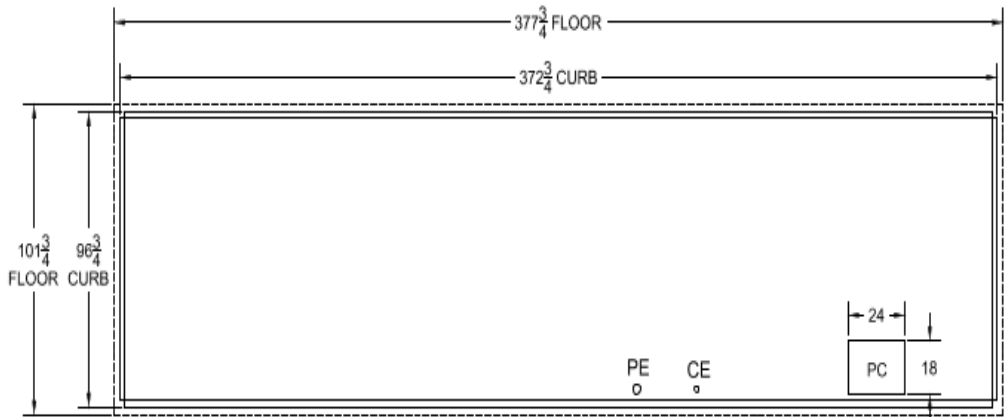

CE: CONTROLS ENTRANCE
PE: POWER ENTRANCE
PC: PIPE CHASE



OA : OUTDOOR AIR SA : SUPPLY AIR RA : RETURN AIR EA : EXHAUST AIR CF1 : CF1 LIGHT : LIGHT LIGHT SWITCH : LIGHT SWITCH MC : MIN CLEARANCE

THERMO-COMPOSITE UNIT

- 1 - 2" CASING
- 2 - OA HOOD (Qty2) w/ 4" LOUVER w/ OA DAMPER
- 3 - MIXING / RECIRCULATION DAMPER
- 4 - 2" MERV10 FILTERS
- 5 - DUAL MODE COIL
- 6 - HOT GAS REHEAT COIL
- 7 - SA DDF (Qty2) ER56C w/ 7.5HP each
- 8 - EA DDF (Qty2) GR63C w/ 7.5HP each
- 9 - EA DAMPER w/ 2" LOUVER
- 10 - WSHP WZ60

TAG: AHU-4

REV
2

DWG. : S-19571
 MODEL : AHU-E-16-D-HR-WZ60
 DATE : 04/04/2018
 WEIGHT :

BY
(FJR)
MEP

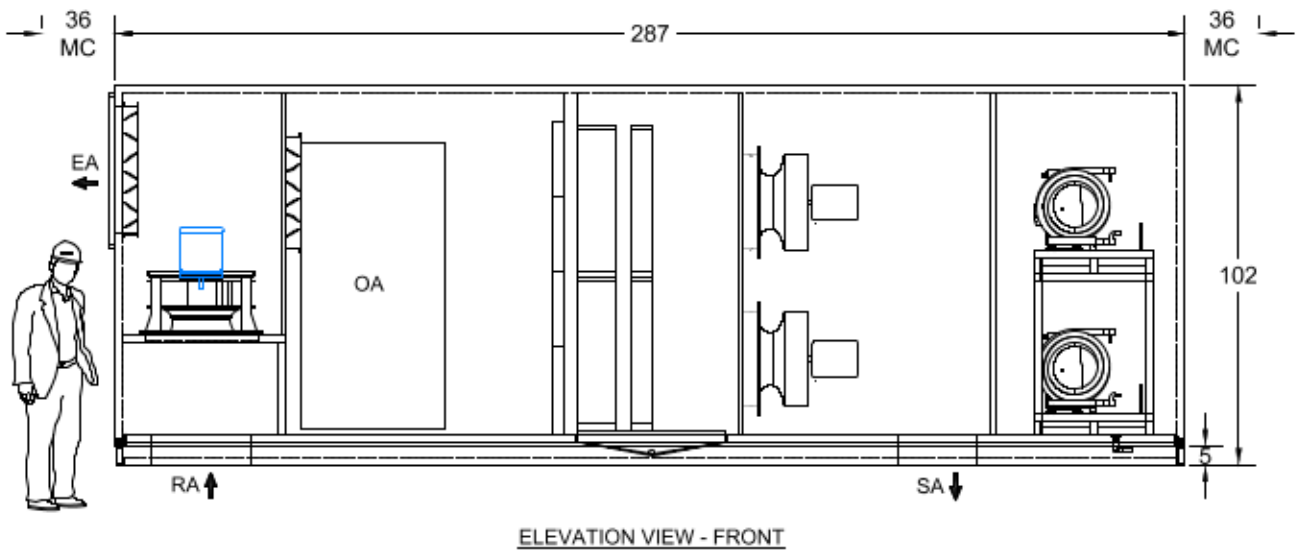
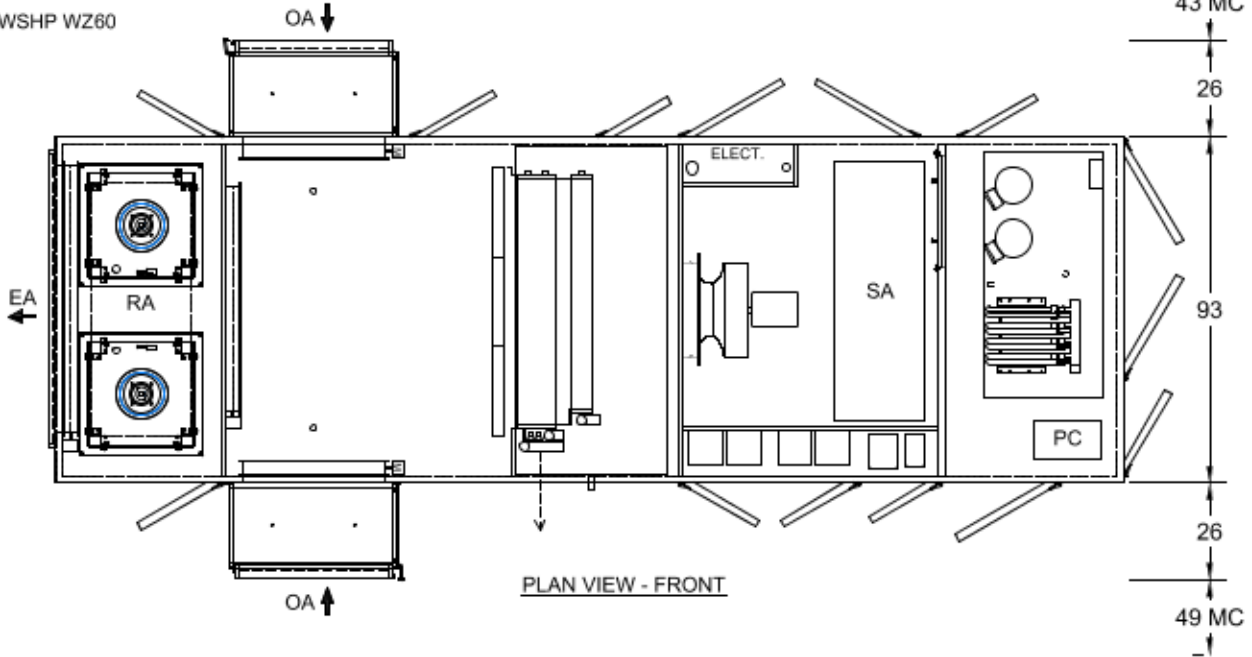

OA : OUTDOOR AIR
 SA : SUPPLY AIR
 RA : RETURN AIR
 EA : EXHAUST AIR
 Φ : GFI
 ⚡ : LIGHT
 ⚡ : LIGHT SWITCH
 MC : MIN. CLEARANCE

THIS DRAWING IS FOR PRELIMINARY PURPOSE ONLY, ANNEXAIR RESERVED THE RIGHT TO CHANGE DESIGN AND COMPONENTS WITHOUT NOTICE. ONLY AT THE SUBMITTAL STAGE DIMENSIONS & WEIGHT WILL BE CONFIRMED FOR FACTORY: DMC: (2) 38"H x 66"L / 34.83sa - HGRC: (2) 38"H x 62"L / 32.72sa



ROOF CURB
FOR REFERENCE ONLY - BY OTHERS

TAG: AHU-4		REV 2
DWG. : S-19571		BY (FJR)
MODEL : AHU-E-16-D-HR-WZ60		MEP
DATE : 04/04/2018		
WEIGHT :		

CE: CONTROL ENTRANCE
PE: POWER ENTRANCE
PC: PIPE CHASE

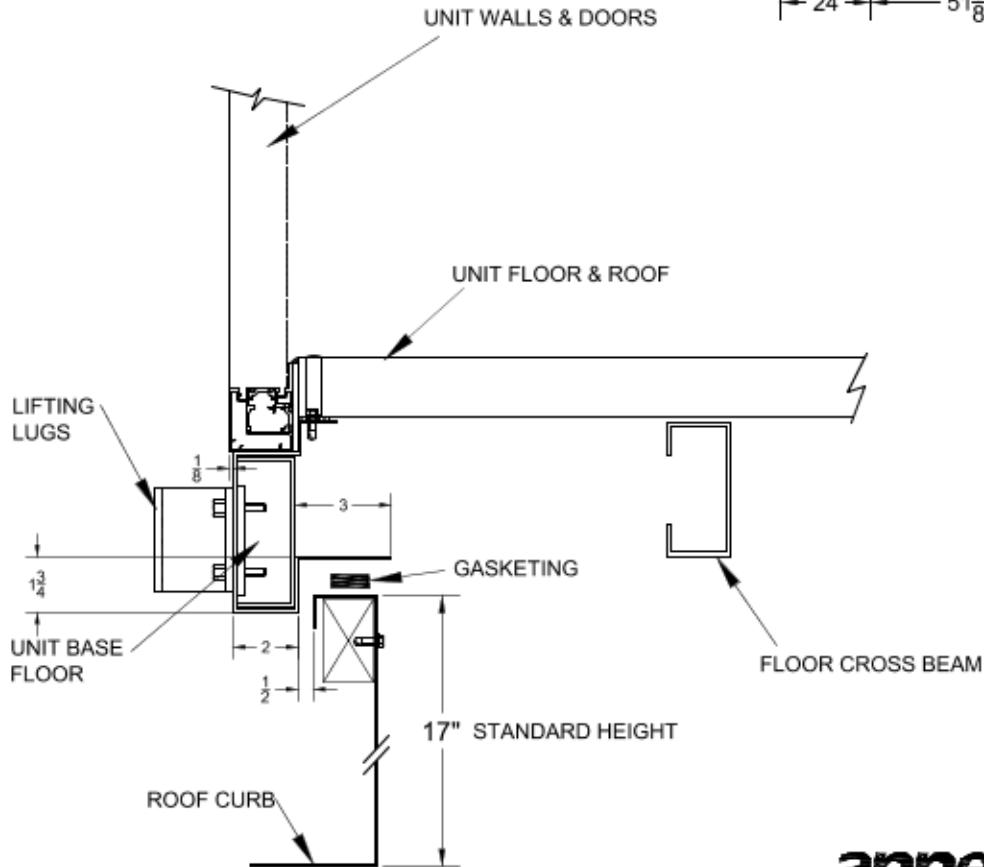
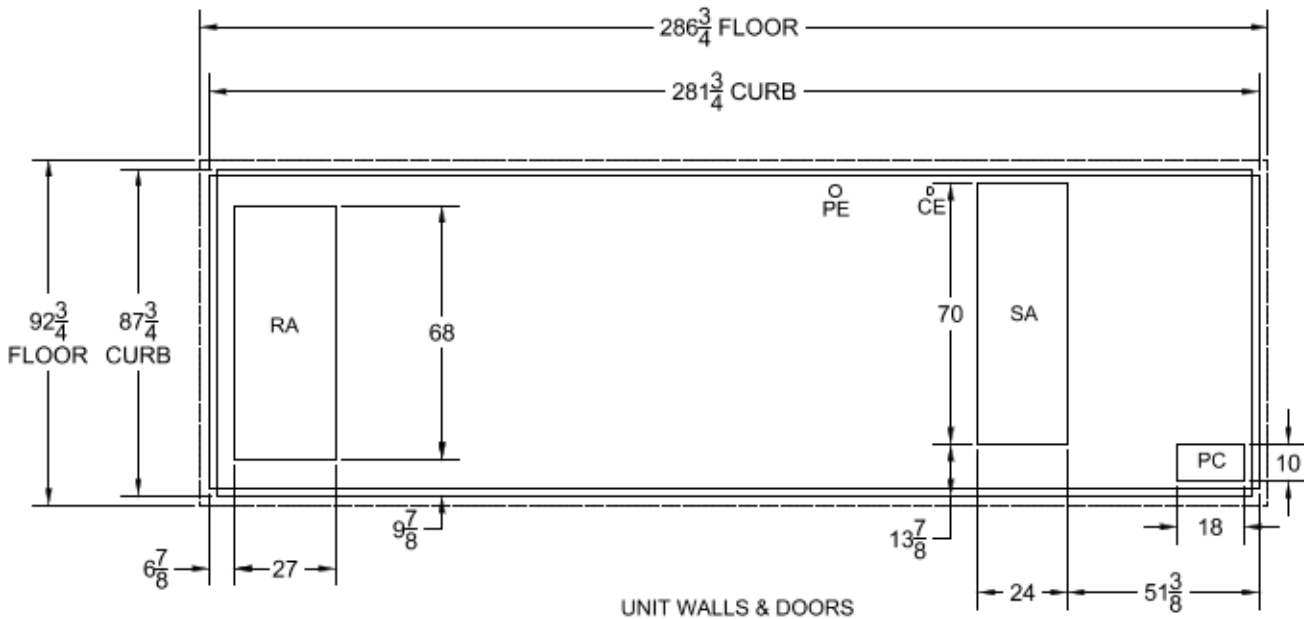

MC : MIN. CLEARANCE
\$: LIGHT SWITCH
⊗ : LIGHT
⊕ : GFI
⊖ : EXHAUST AIR
EA : EXHAUST AIR
RA : RETURN AIR
SA : SUPPLY AIR
OA : OUTDOOR AIR



THERMO-COMPOSITE UNIT

- 1 - 2" CASING
- 2 - OA HOOD (Qty2) w/ 4" LOUVER w/ OA DAMPER
- 3 - MIXING / RECIRCULATION DAMPER
- 4 - 2" MERV10 FILTERS
- 5 - DUAL MODE COIL
- 6 - HOT GAS REHEAT COIL
- 7 - SA DDF (Qty2) ER56C w/ 7.5HP each
- 8 - EA DDF (Qty2) GR63C w/ 7.5HP each
- 9 - EA DAMPER w/ 2" LOUVER
- 10 - WSHP WZ60

TAG: AHU-5/AHU-8		REV 0
DWG. : S-19571		BY
MODEL : AHU-E-16-D-HR-WZ60		(FJR)
DATE : 04/04/2018		MEP
WEIGHT :		

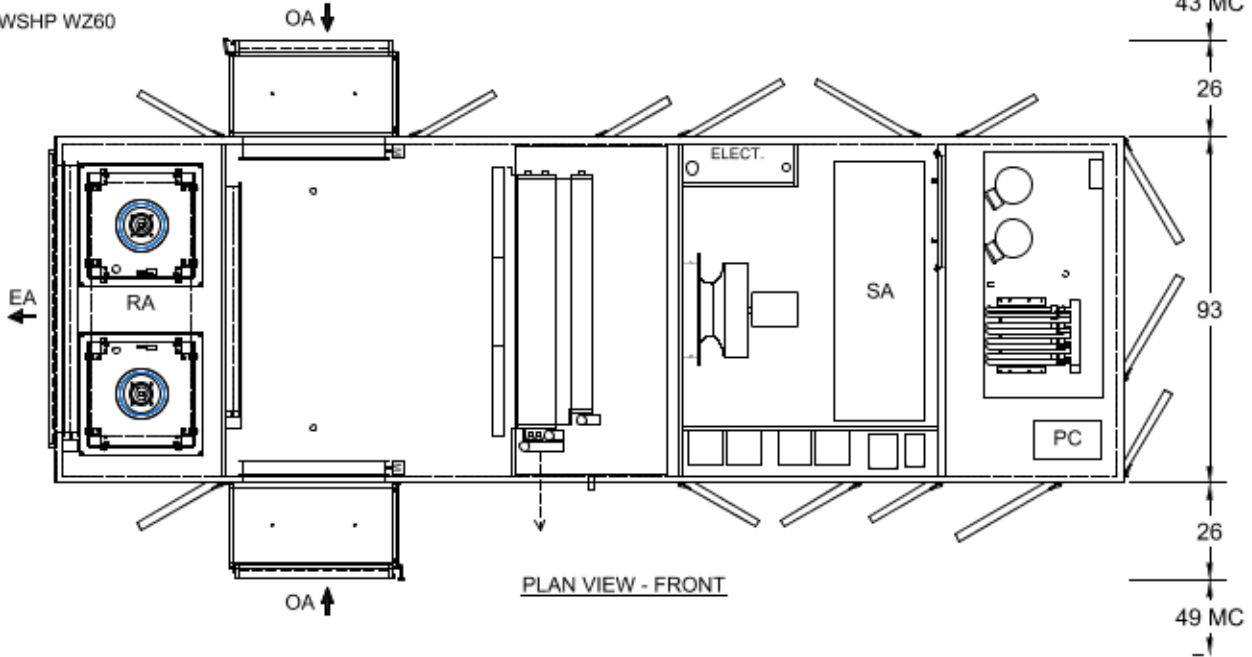

OA : OUTDOOR AIR
 SA : SUPPLY AIR
 RA : RETURN AIR
 EA : EXHAUST AIR
 Φ : EXHAUST AIR
 ⚡ : GFI
 ⚡ : LIGHT
 ⚡ : LIGHT SWITCH
 MC : MIN. CLEARANCE

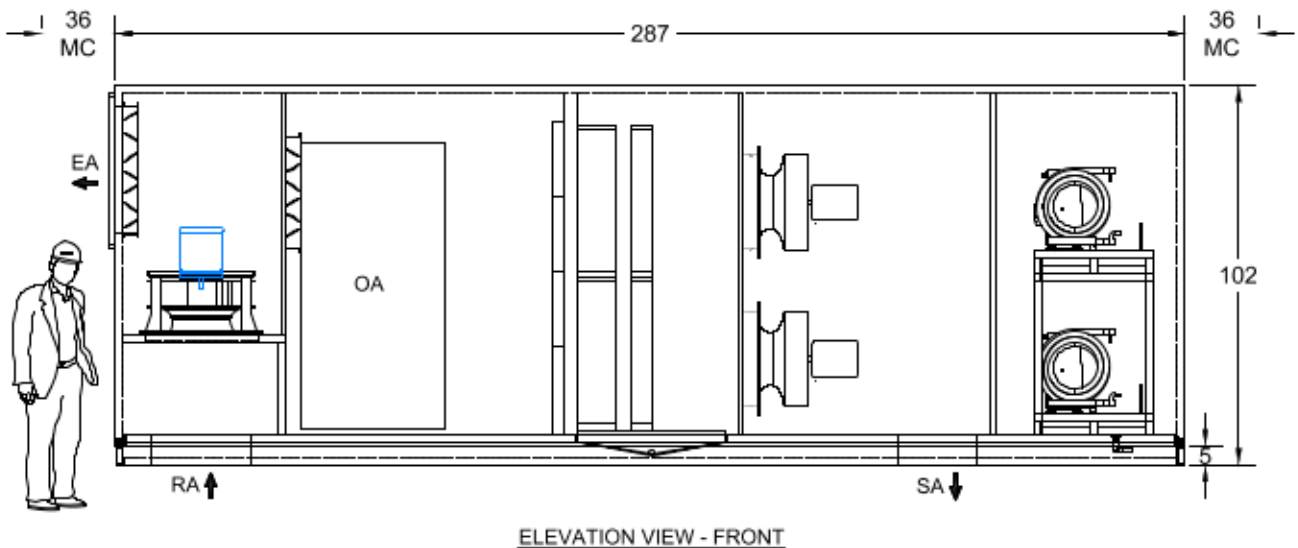

THIS DRAWING IS FOR PRELIMINARY PURPOSE ONLY, ANNEXAIR RESERVED THE RIGHT TO CHANGE DESIGN AND COMPONENTS WITHOUT NOTICE. ONLY AT THE SUBMITTAL STAGE DIMENSIONS & WEIGHT WILL BE CONFIRMED FOR FACTORY: DMC: (2) 38"H x 66"L / 34.83sa - HGRC: (2) 38"H x 62"L / 32.72sa



ROOF CURB
FOR REFERENCE ONLY - BY OTHERS

TAG: AHU-5/AHU-8

REV
0

DWG. : S-19571
MODEL : AHU-E-16-D-HR-WZ60
DATE : 04/04/2018
WEIGHT :

BY
(FJR)
MEP

CE: CONTROL ENTRANCE
PE: POWER ENTRANCE
PC: PIPE CHASE

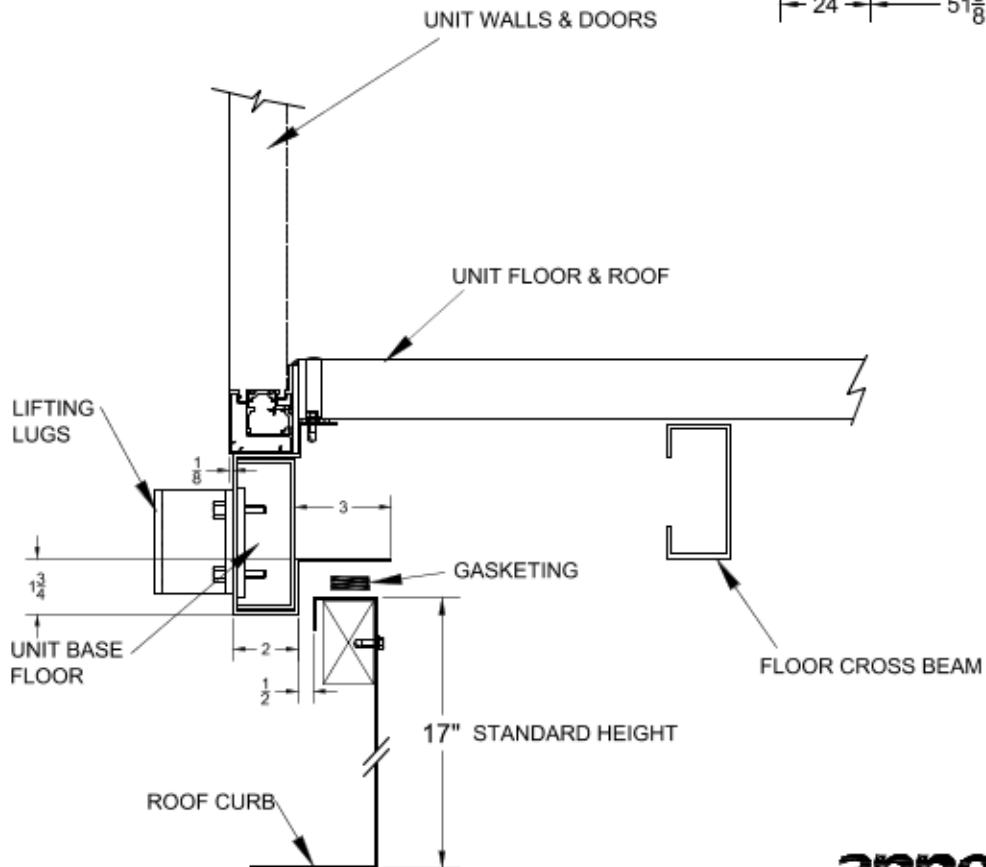
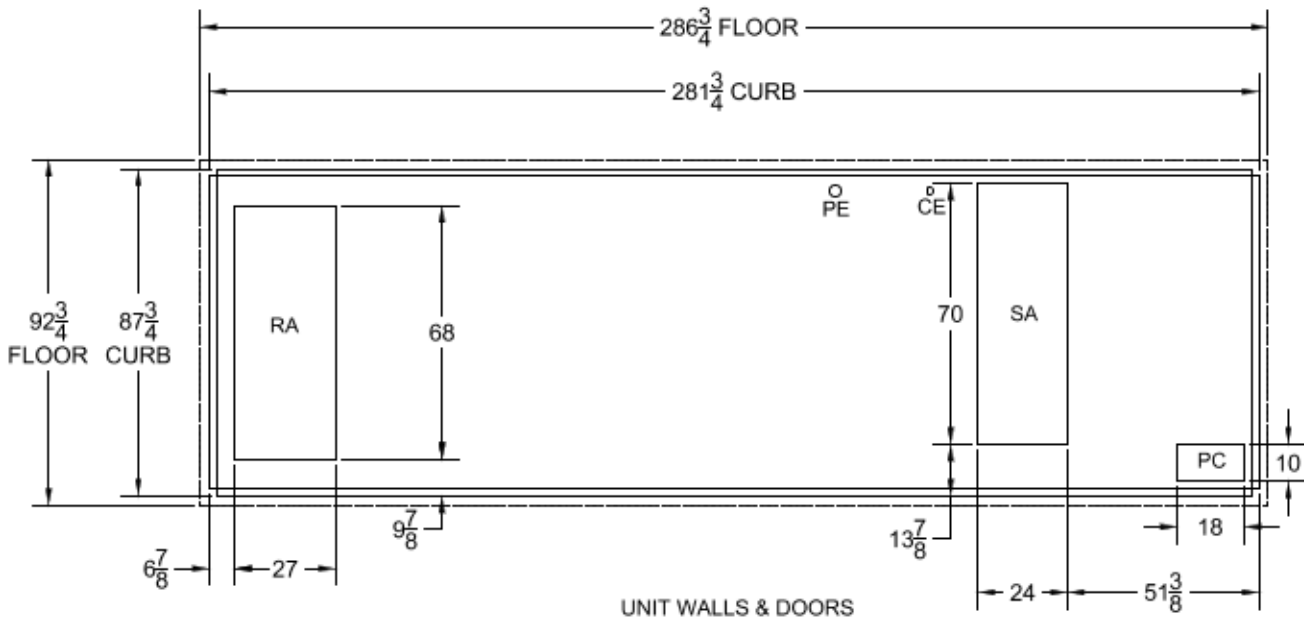

MC : MIN. CLEARANCE
\$: LIGHT SWITCH
⊗ : LIGHT
⊕ : GFI
⊕ : EXHAUST AIR
EA : EXHAUST AIR
RA : RETURN AIR
SA : SUPPLY AIR
OA : OUTDOOR AIR

annexAir

THERMO-COMPOSITE UNIT

- 1 - 2" DW CASING
- 2 - OA HOOD w/ 4" LOUVER w/ 2" MERV10 FILTERS
- 3 - OA DAMPER
- 4 - ENTHALPY WHEEL 25 w/ GEARDRIVE
- 5 - DUAL MODE COIL
- 6 - HOT GAS REHEAT COIL
- 7 - SA DDF (Qty4) ER56C w/ 7.5HP each
- 8 - 2" MERV10 RA FILTERS
- 9 - EA DDF (Qty2) ER80C w/ 15HP each
- 10 - EA DAMPER w/ 2" LOUVER
- 11 - WSHP (Qty2) WZ52

TAG: AHU-6/AHU-7	REV 2
DWG. : S-19571	BY
MODEL : ERP-E-25-EW-D-HR-2WZ52	(FJR)
DATE : 04/04/2018	MEP
WEIGHT :	

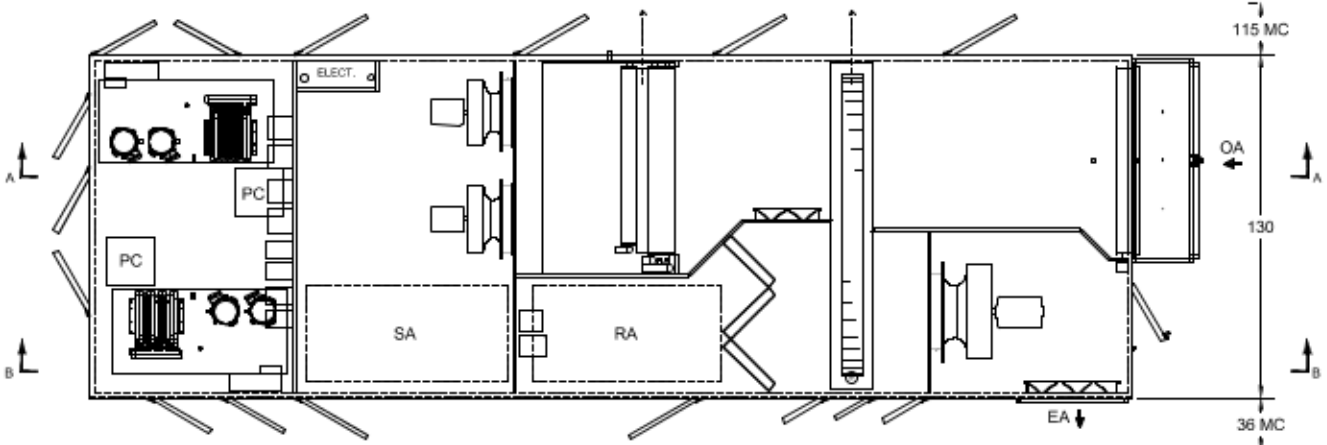

PLAN VIEW - FRONT

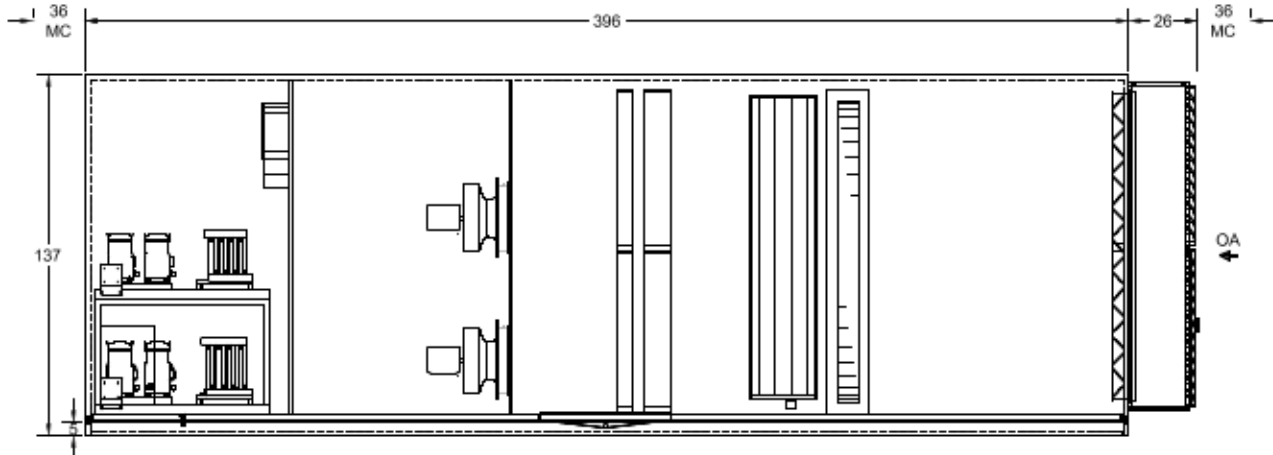

ELEVATION VIEW - AA

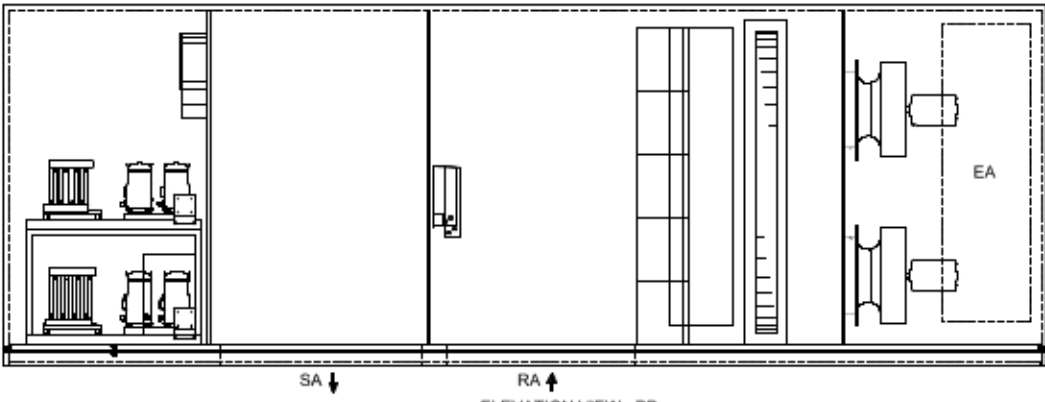

ELEVATION VIEW - BB

THIS DRAWING IS FOR PRELIMINARY PURPOSE ONLY, ANNEXAIR RESERVED THE RIGHT TO CHANGE DESIGN AND COMPONENTS WITHOUT NOTICE. ONLY AT THE SUBMITTAL STAGE DIMENSIONS & WEIGHT WILL BE CONFIRMED FOR FACTORY: DMC: (2) 58"H x 70"L / 56.38sa - HGRC: (2) 58"H x 66"L / 53.16sa



OA : OUTDOOR AIR SA : SUPPLY AIR RA : RETURN AIR EA : EXHAUST AIR Φ : GFI ⚡ : LIGHT SWITCH MC : MIN. CLEARANCE

ROOF CURB
FOR REFERENCE ONLY - BY OTHERS

TAG: AHU-6/AHU-7

REV
2

DWG. : S-19571
MODEL : ERP-E-25-EW-D-HR-2WZ52
DATE : 04/04/2018
WEIGHT :

BY
(FJR)
MEP

CE: CONTROLS ENTRANCE
PE: POWER ENTRANCE
PC: PIPE CHASE

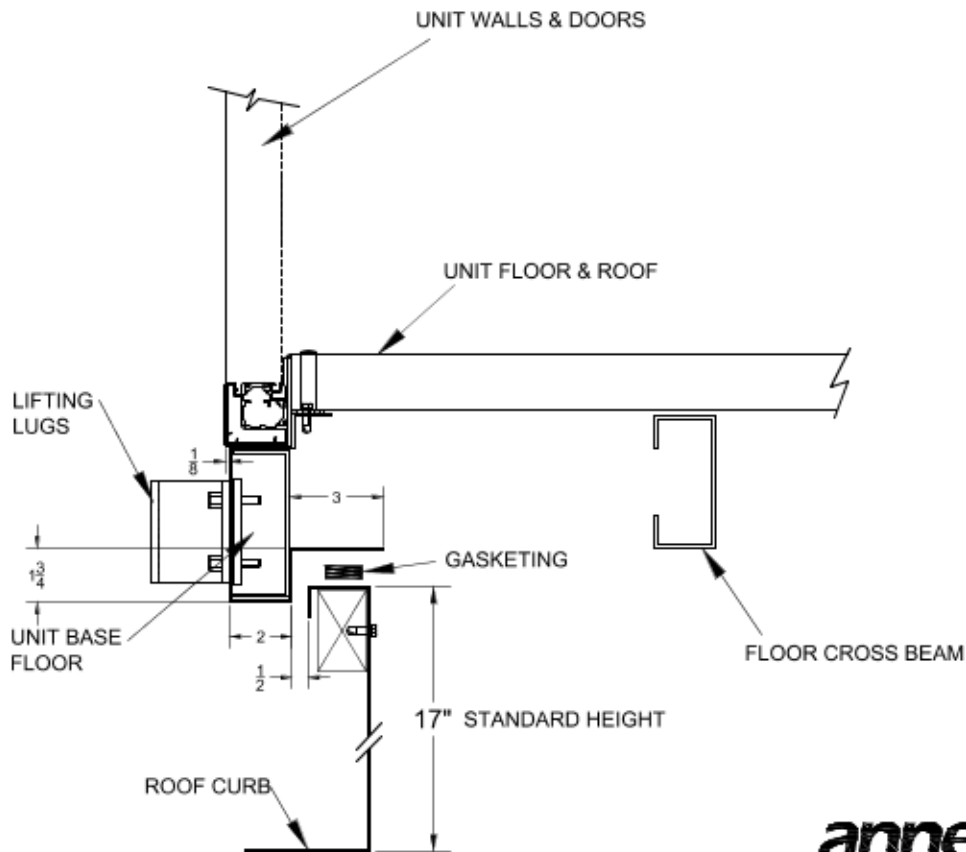
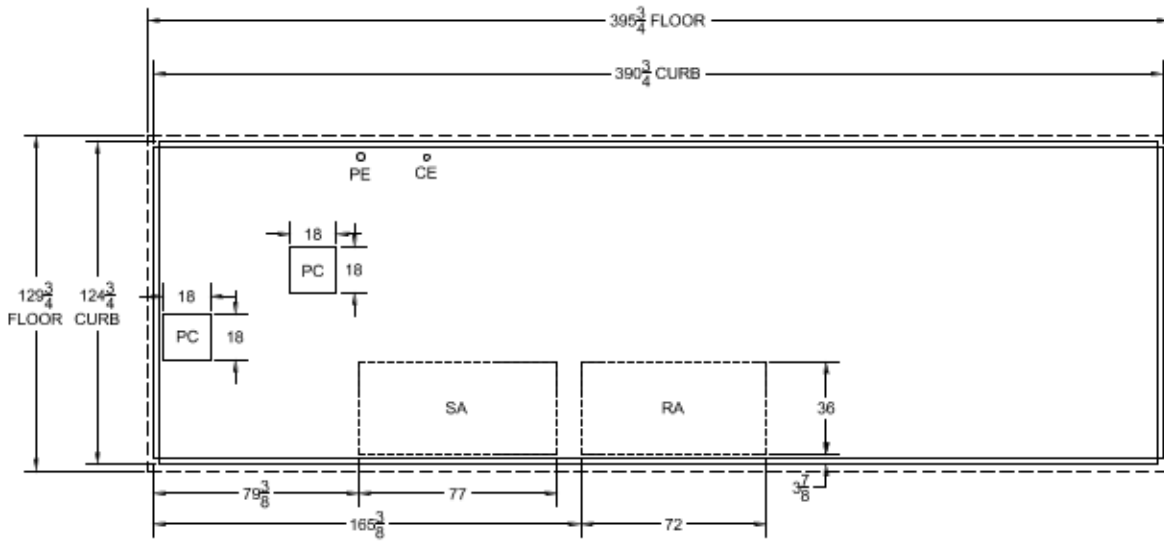

OA : OUTDOOR AIR
SA : SUPPLY AIR
RA : RETURN AIR
EA : EXHAUST AIR
Φ : EXHAUST AIR
⊕ : GFI
⚡ : LIGHT SWITCH
\$: LIGHT
⚡ : LIGHT
MC : MIN. CLEARANCE

annexAir

THERMO-COMPOSITE UNIT

- 1 - 2" CASING
- 2 - OA HOOD w/ 4" LOUVER w/ OA DAMPER
- 3 - MIXING / RECIRCULATION DAMPER
- 4 - 2" MERV10 FILTERS
- 5 - DUAL MODE COIL
- 6 - HOT GAS REHEAT COIL
- 7 - SA DDF ER56C w/ 7.5HP each
- 8 - EA DDF GR56C w/ 5HP each
- 9 - EA DAMPER w/ 2" LOUVER
- 10 - WSHP WZ24

TAG: AHU-9

REV
2

DWG. : S-19571
 MODEL : AHU-E-05-D-HR-WZ24
 DATE : 04/04/2018
 WEIGHT :

BY
(FJR)
MEP

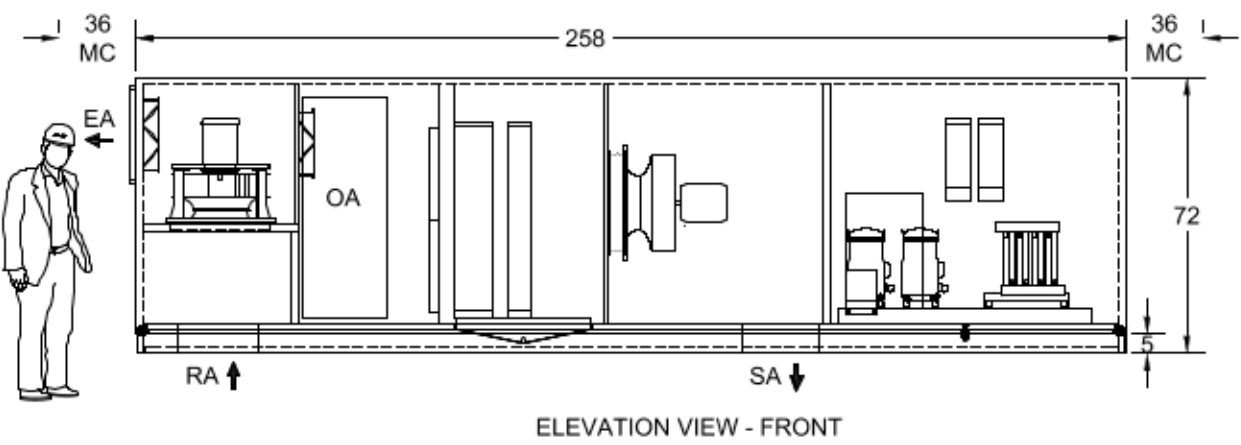
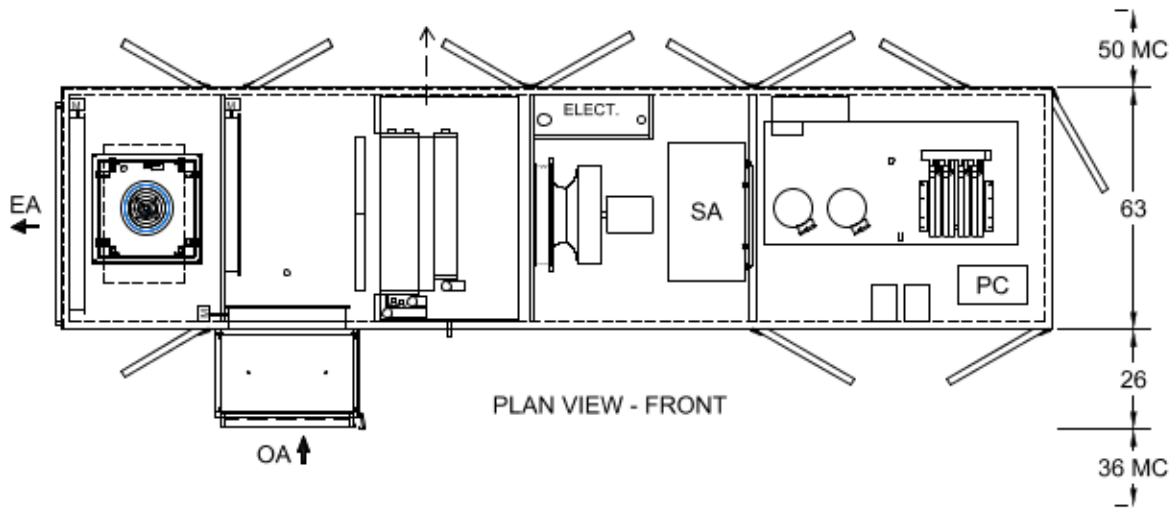

OA : OUTDOOR AIR SA : SUPPLY AIR RA : RETURN AIR EA : EXHAUST AIR Φ : GFI ⚡ : LIGHT SWITCH \$: LIGHT ⚡ : LIGHT ⚡ : LIGHT MC : MIN. CLEARANCE

THIS DRAWING IS FOR PRELIMINARY PURPOSE ONLY, ANNEXAIR RESERVED THE RIGHT TO CHANGE DESIGN AND COMPONENTS WITHOUT NOTICE. ONLY AT THE SUBMITTAL STAGE DIMENSIONS & WEIGHT WILL BE CONFIRMED FOR FACTORY: DMC: 48"H x 40"L / 13.33sa - HGRC: 48"H x 36"L / 12sa



TAG: AHU-9	REV 2
DWG. : S-19571	BY (FJR)
MODEL : AHU-E-05-D-HR-WZ24	MEP
DATE : 04/04/2018	
WEIGHT :	

ROOF CURB
FOR REFERENCE ONLY - BY OTHERS

CE: CONTROLS ENTRANCE
PE: POWER ENTRANCE
PC: PIPE CHASE

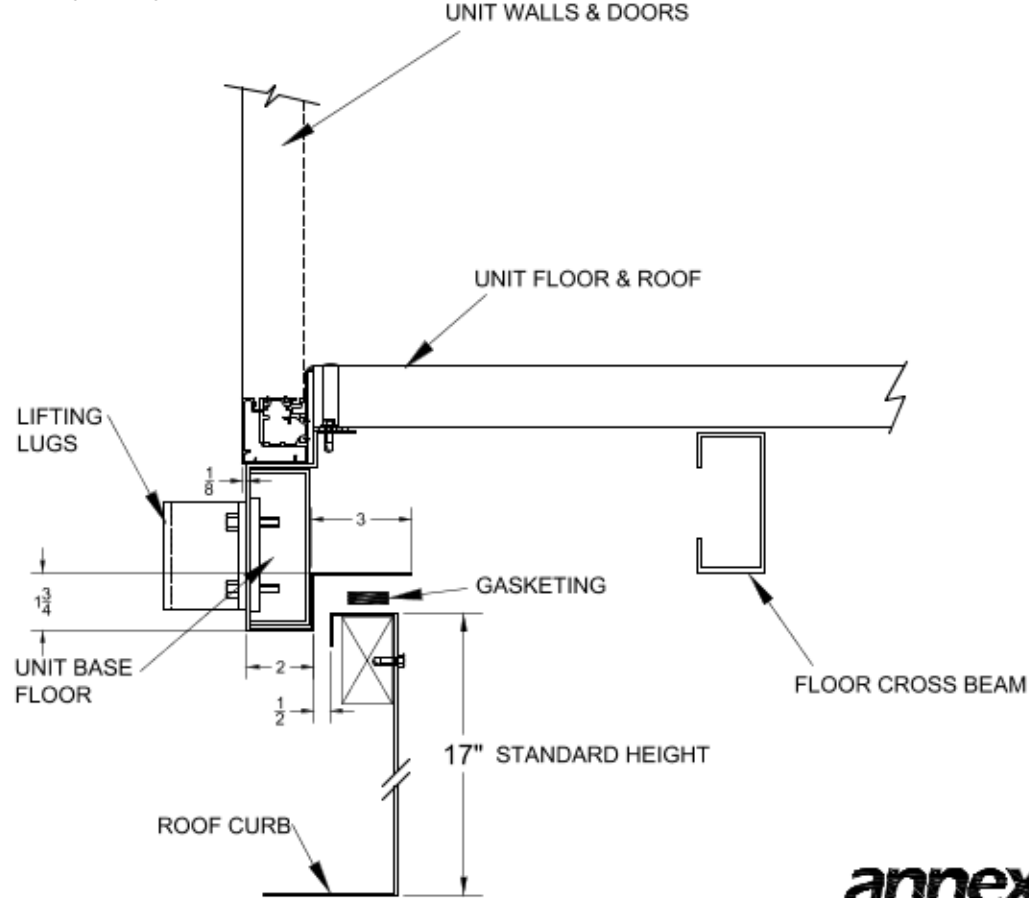
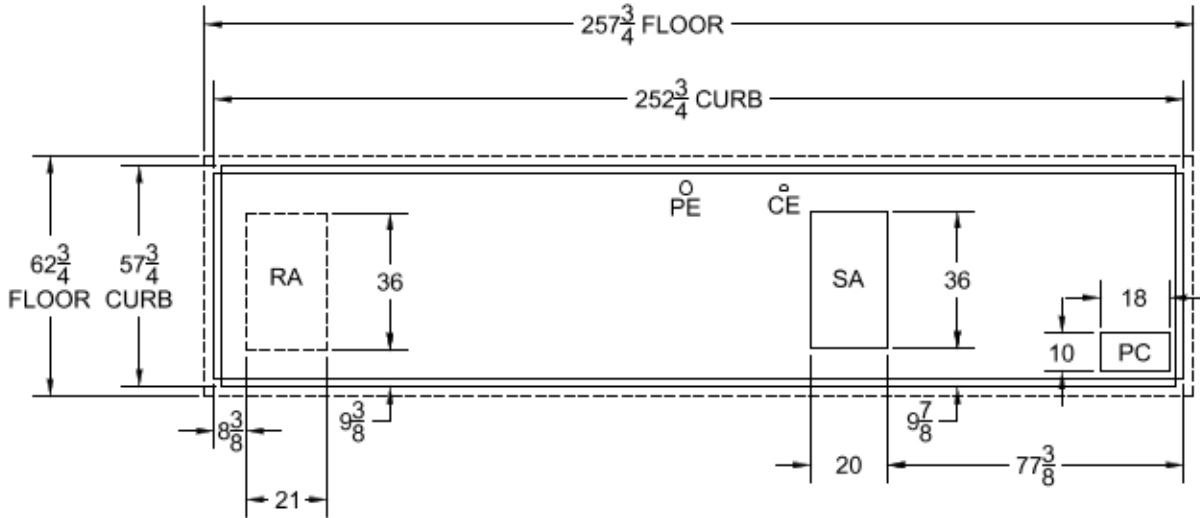

MC : MIN. CLEARANCE
LIGHT SWITCH
LIGHT
GFI
EXHAUST AIR
RETURN AIR
SUPPLY AIR
OUTDOOR AIR



THERMO-COMPOSITE UNIT

- 1 - 2" CASING
- 2 - OA HOOD (Qty2) w/ 4" LOUVER w/ OA DAMPER
- 3 - MIXING / RECIRCULATION DAMPER
- 4 - 2" MERV10 FILTERS
- 5 - DUAL MODE COIL
- 6 - HOT GAS REHEAT COIL
- 7 - SA DDF (Qty2) ER56C w/ 5HP each
- 8 - EA DDF (Qty2) GR50C w/ 5HP each
- 9 - EA DAMPER w/ 2" LOUVER
- 10 - WSHP WZ30

TAG: AHU-10

REV
2

DWG. : S-19571
 MODEL : AHU-E-09-D-HR-WZ30
 DATE : 04/04/2018
 WEIGHT :

BY
(FJR)
MEP

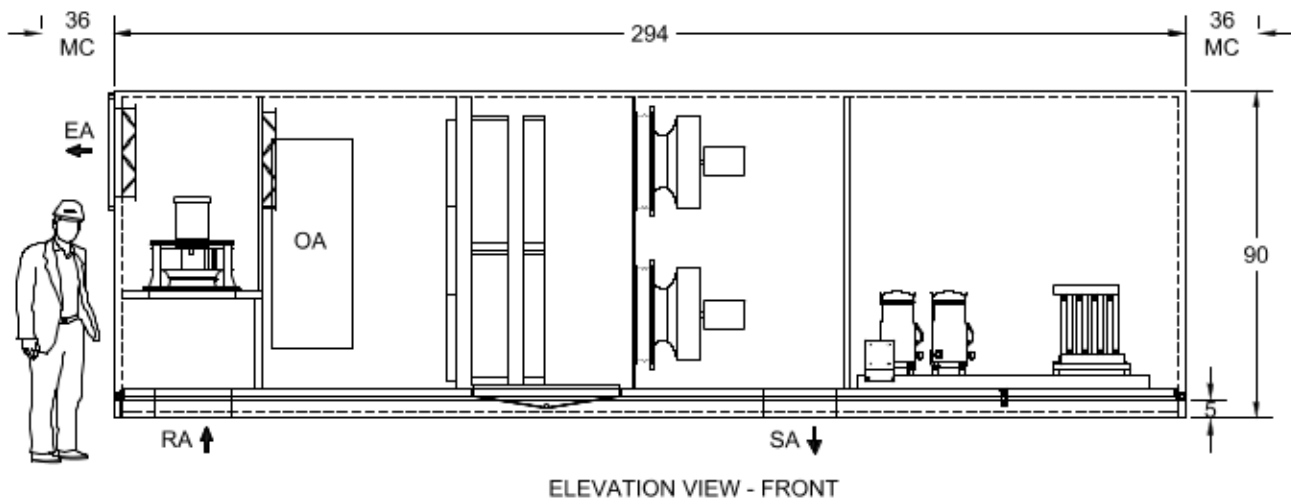
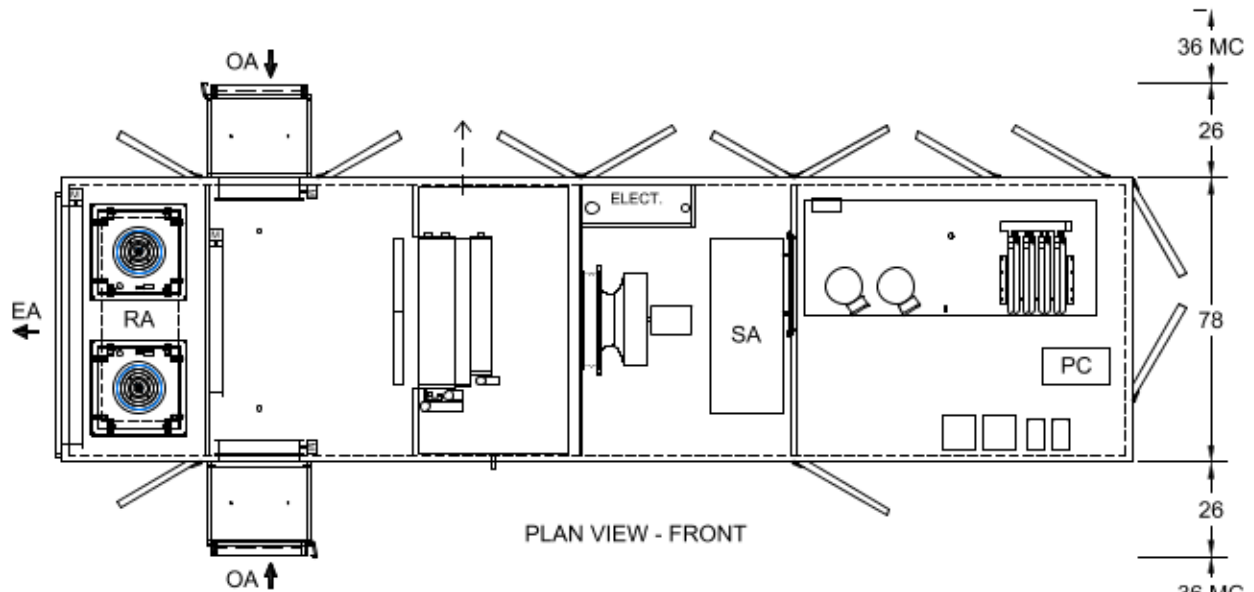

OA : OUTDOOR AIR
 SA : SUPPLY AIR
 RA : RETURN AIR
 EA : EXHAUST AIR
 Φ : GFI
 ⚡ : LIGHT
 ⚡ : LIGHT SWITCH
 MC : MIN. CLEARANCE

THIS DRAWING IS FOR PRELIMINARY PURPOSE ONLY, ANNEXAIR RESERVED THE RIGHT TO CHANGE DESIGN AND COMPONENTS WITHOUT NOTICE. ONLY AT THE SUBMITTAL STAGE DIMENSIONS & WEIGHT WILL BE CONFIRMED FOR FACTORY: DMC: (2) 34"H x 40"L / 18.88sa - HGRC: (2) 34"H x 36"L / 17sa



THERMO-COMPOSITE UNIT

- 1 - 2" D/W CASING
- 2 - OA HOOD w/ 4" LOUVER w/ 2" MERV10 OA FILTERS
- 3 - OA DAMPER
- 4 - DUAL MODE COIL
- 5 - HOT GAS REHEAT COIL
- 6 - SA DDF (Qty2) ER63C w/ 10HP each
- 7 - WSHP WZP96

TAG: MAU-1

REV
1

DWG. : S-19571
 MODEL : MAU-E-16-D-HR-WZ96
 DATE : 04/13/2018
 WEIGHT :

BY
(FJR)
MEP

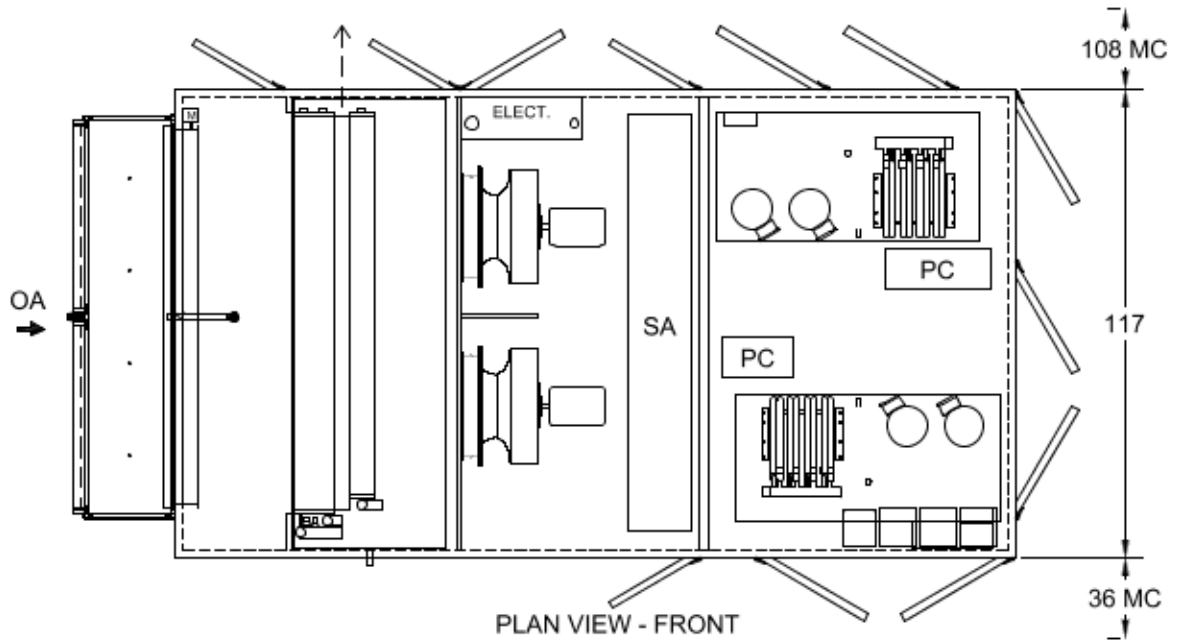

PLAN VIEW - FRONT

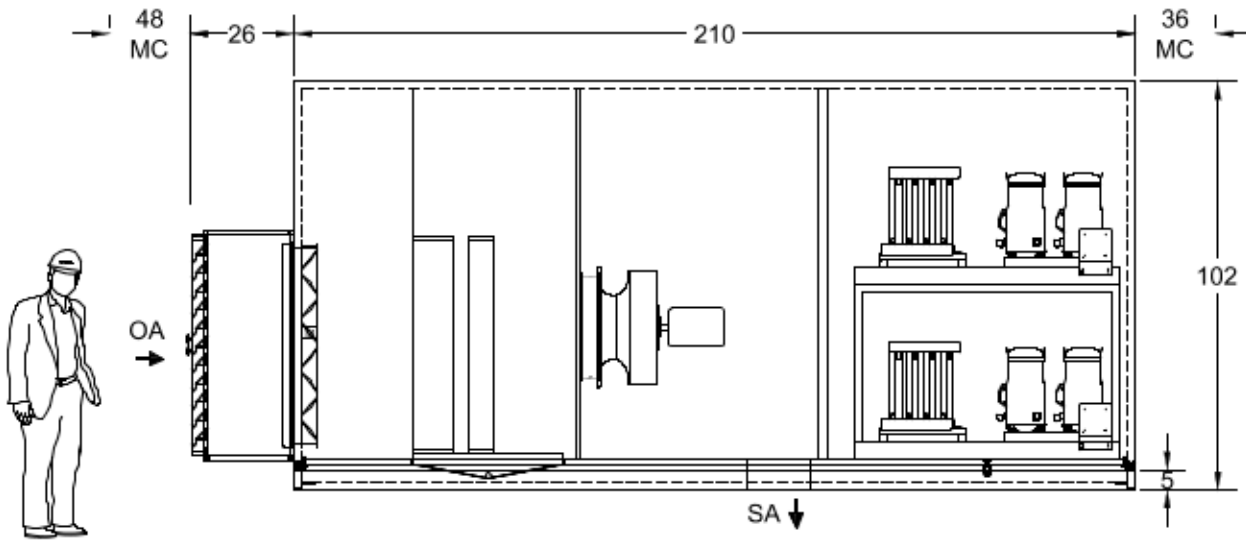

ELEVATION VIEW - FRONT

OA : OUTDOOR AIR SA : SUPPLY AIR RA : RETURN AIR EA : EXHAUST AIR Φ : GFI ⚡ : LIGHT \$: LIGHT SWITCH MC : MIN. CLEARANCE

THIS DRAWING IS FOR PRELIMINARY PURPOSE ONLY, ANNEXAIR RESERVED THE RIGHT TO CHANGE DESIGN AND COMPONENTS WITHOUT NOTICE. ONLY AT THE SUBMITTAL STAGE DIMENSIONS & WEIGHT WILL BE CONFIRMED FOR FACTORY: DMC: 52"H x 98"L / 35.38sa - HGRC: 52"H x 94"L / 33.94sa



ROOF CURB
FOR REFERENCE ONLY - BY OTHERS

TAG: MAU-1	REV 1
DWG. : S-19571	BY (FJR)
MODEL : MAU-E-16-D-HR-WZ96	MEP
DATE : 04/13/2018	
WEIGHT :	

CE: CONTROLS ENTRANCE
PE: POWER ENTRACNE
PC: PIPE CHASE

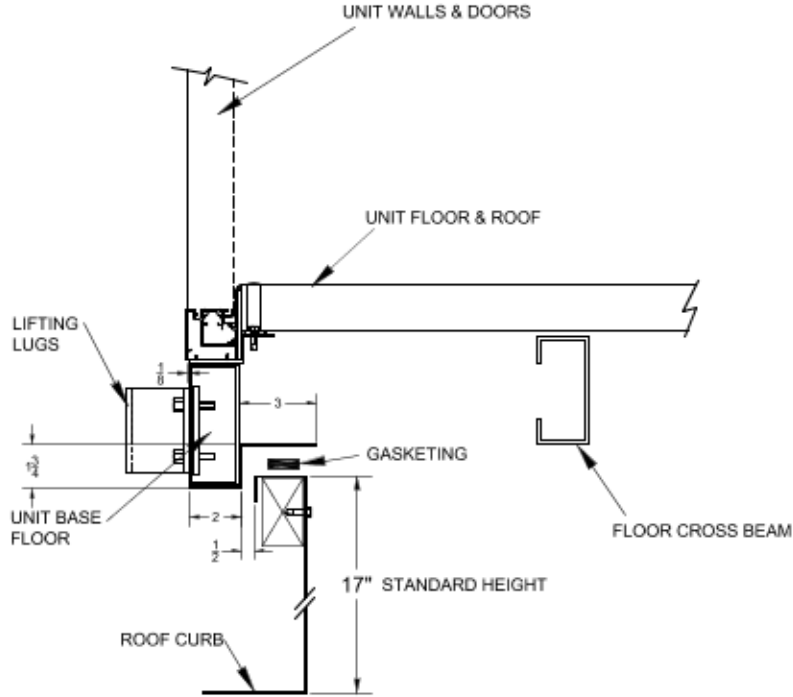
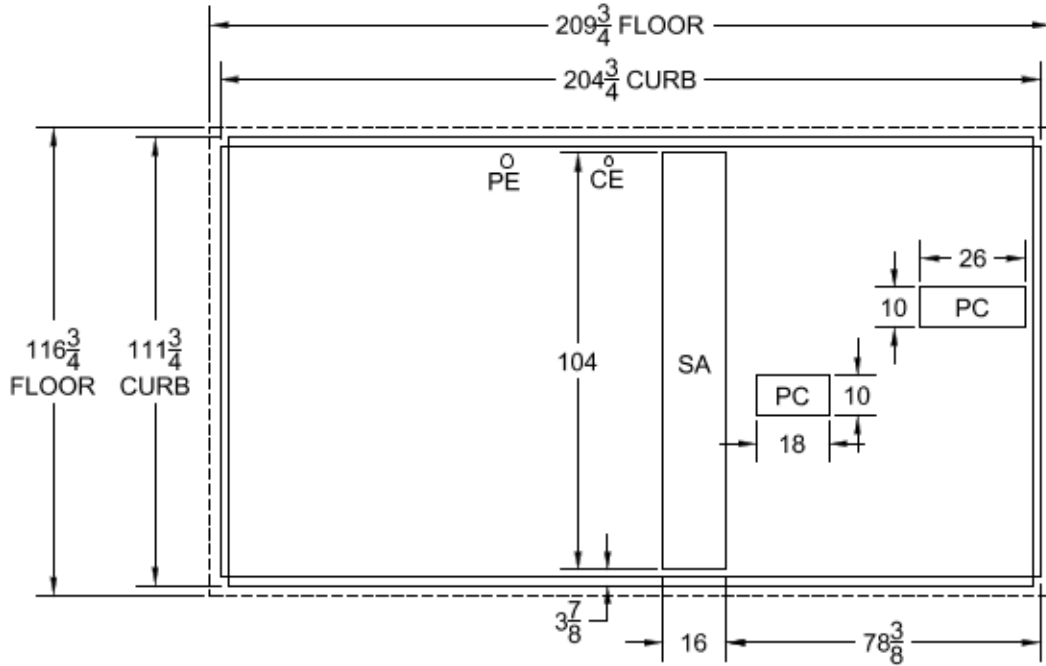

OA : OUTDOOR AIR
SA : SUPPLY AIR
RA : RETURN AIR
EA : EXHAUST AIR
Φ : GFI
⚡ : LIGHT SWITCH
\$: LIGHT
MC : MIN. CLEARANCE



THERMO-COMPOSITE UNIT

- 1 - 2" D/W CASING
- 2 - OA HOOD w/ 4" LOUVER
w/ 2" MERV10 FILTERS
- 3 - OA DAMPER
- 4 - DUAL MODE COIL
- 5 - HOT GAS REHEAT COIL
- 6 - SA DDF (Qty2) GR45C w/ 5HP each
- 7 - WSHP WZ52

TAG: MAU-2	REV 0
DWG. : S-19571	BY
MODEL : MAU-E-07-D-HR-WZ52	(FJR)
DATE : 04/30/2018	MEP
WEIGHT :	

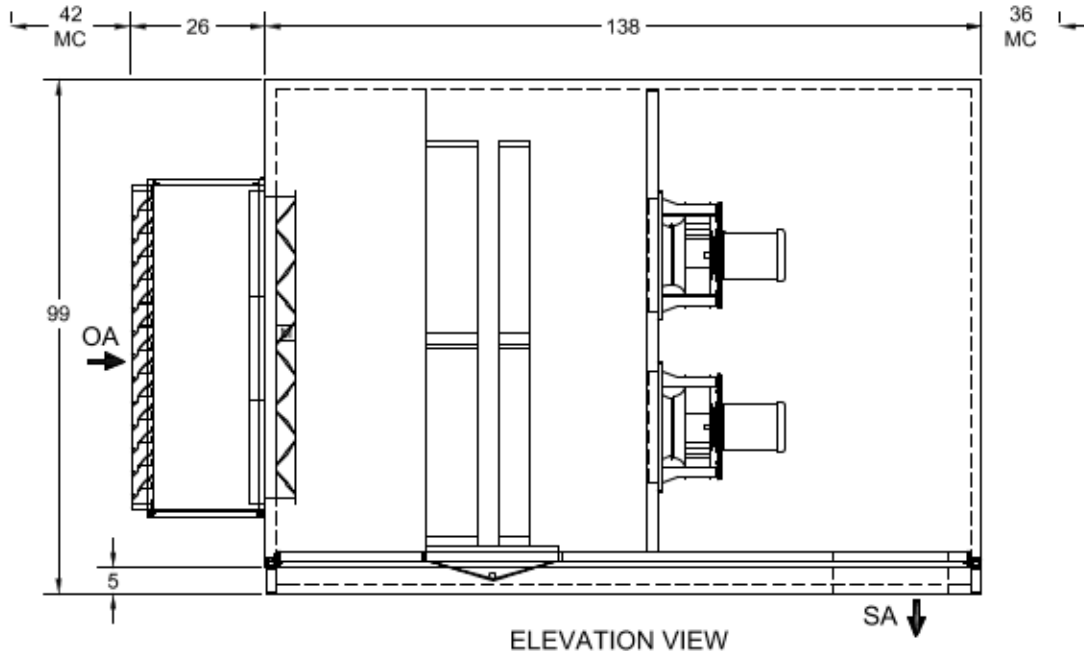
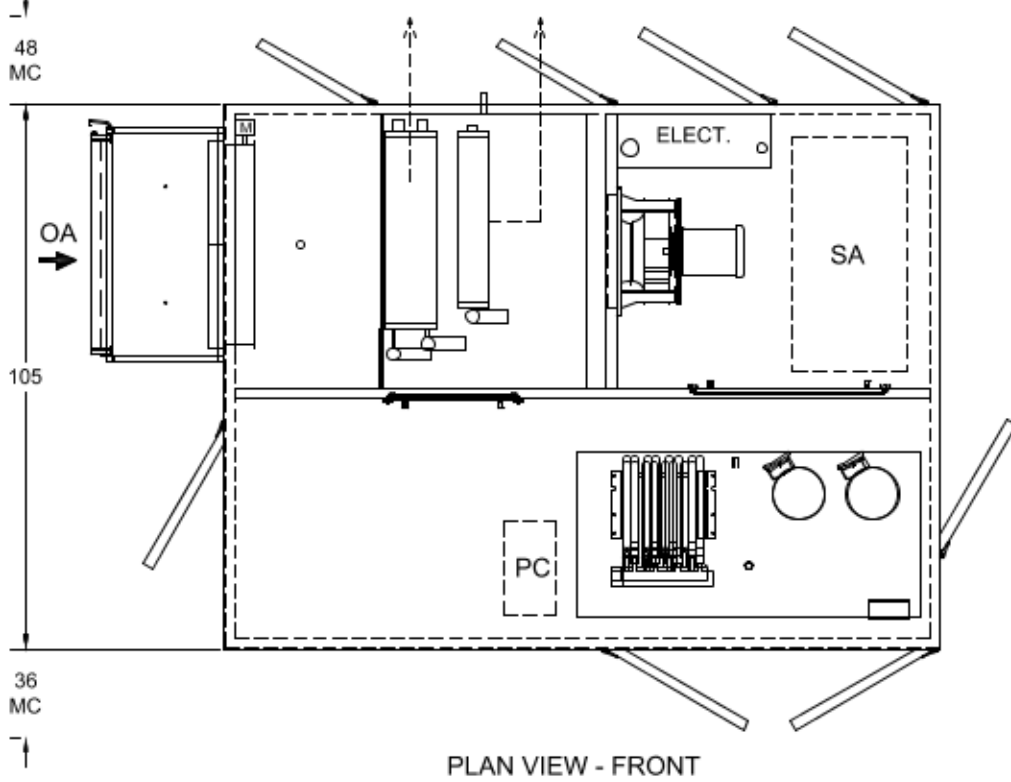

THIS DRAWING IS FOR PRELIMINARY PURPOSE ONLY, ANNEXAIR RESERVED THE RIGHT TO CHANGE DESIGN AND COMPONENTS WITHOUT NOTICE. ONLY AT THE SUBMITTAL STAGE DIMENSIONS & WEIGHT WILL BE CONFIRMED FOR FACTORY: DMC: (2) 36"H x 36"L / 18sa - HGRC: (2) 36"H x 32"L / 16sa



OA : OUTDOOR AIR SA : SUPPLY AIR RA : RETURN AIR EA : EXHAUST AIR Φ : GFI ⚡ : LIGHT ⚡ : LIGHT SWITCH \$: LIGHT SWITCH MC : MIN. CLEARANCE

ROOF CURB
FOR REFERENCE ONLY - BY OTHERS

TAG: MAU-2	REV 0
DWG. : S-19571	BY (FJR)
MODEL : MAU-E-07-D-HR-WZ52	MEP
DATE : 04/30/2018	
WEIGHT :	

CE: CONTROLS ENTRANCE
PE: POWER ENTRANCE
PC: PIPE CHASE

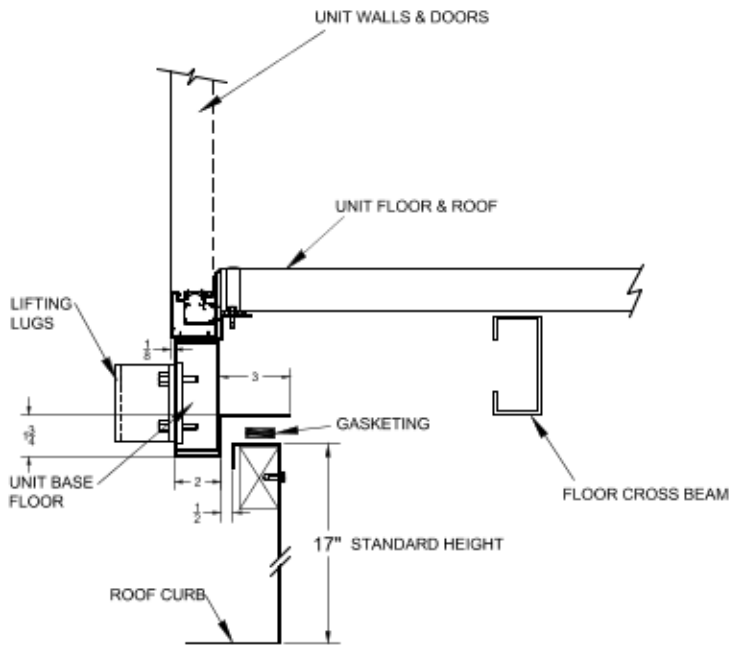
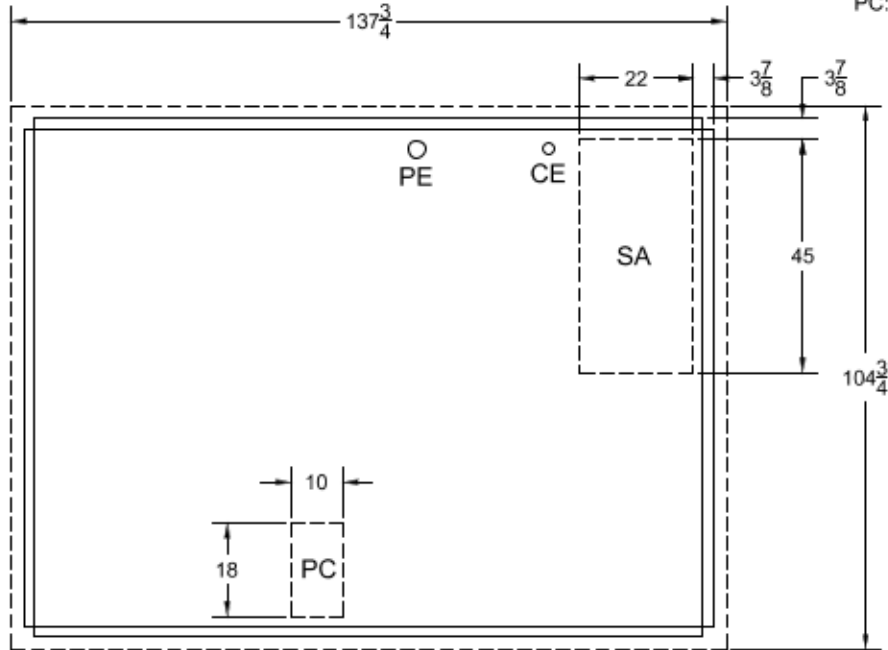

MC : MIN. CLEARANCE
LIGHT SWITCH
\$
LIGHT
GFI
EA : EXHAUST AIR
RA : RETURN AIR
SA : SUPPLY AIR
OA : OUTDOOR AIR

SECTION 15XXX
AIR HANDLING UNIT / DEDICATED OUTDOOR AIR SYSTEM / ENERGY RECOVERY
UNIT

1. PART I – GENERAL

1.1 WORK INCLUDED

- A. This specification is based on an Energy Recovery model as manufactured by Annexair Inc. Manufacturers of alternate equipment must be approved to bid via addendum, in writing by the specifying engineer, at least two weeks prior to bid time in order for their bid to be accepted by the contractor. If the equipment is not pre-approved then under no circumstances shall the contractor invest any time or money in receiving submittals or considering the equipment. Costs associated with dimensional, performance or other deviations from the specified equipment, including engineering costs to evaluate such deviations, shall be paid by the contractor
- B. The units shall be installed in strict accordance with the specifications. Unit(s) shall be complete with all components and accessories as specified. All units shall be factory assembled, internally wired, and 100% run tested to check operation, fan/blower rotation and control sequence before leaving the factory. Wiring internal to the unit shall be numbered for simplified identification. Units shall be ETL listed and labeled, classified in accordance with ANSI-UL 1995 / CAN/CSA C22.2 No.236.
- C. Equipment start-up and project inspection by qualified factory trained representative.

1.2 QUALITY ASSURANCE

- A. All units shall be factory run tested before shipping. A proof copy of the test shall be placed in the unit electrical power & control panel.
- B. Unit(s) shall bear the ETL label, tested in accordance to UL 1995. Electrical components shall be UL listed.
- C. Fans shall be tested in an AMCA certified laboratory; insulation shall comply with NFPA 90A.
- D. Coils shall be tested in accordance to AHRI 410.
- E. Energy recovery exchangers shall be in accordance to AHRI 1060, “Rating Air-to-Air Energy Recovery Equipment” and Eurovent standards.
- F. Filters shall be tested in accordance to ASHRAE 52.

- G. The unit manufacturers construction shall have an independent testing agency test the air leakage, panel deflection and sound pressure levels for supply airflows of minimum 20,000 CFM. The air leakage of the unit(s) shall not exceed 1% at 8” inches H₂O positive static pressure and a copy of the report must be submitted upon request. Unit shall be constructed to limit frame and panel deflection to 1/250th of the panel length at 8” inches H₂O positive static pressure and a copy of the report must be submitted upon request. The unit shall also be tested in accordance with ANSI S12.34-1998 and instrumentation used must be in compliance with the requirements of AMCA 300 for sound readings. The sound tests conducted shall report overall sound power and pressure readings for supply air outlet, return air inlet and casing radiated.
- H. Products shall be supported with a warranty that ensures the product will be free from defects in materials and workmanship for a period of one year after shipment.

1.3 SUBMITTALS

- A. Submit product data under provisions of Section 15XXX. Include product description, model, dimensions, component sizes, rough-in requirements, service sizes, and finishes. Include rated capacities, operating weights, furnished specialties, and accessories.
- B. Submit manufacturer’s installation instructions.
- C. Submit operation and maintenance data.
- D. Submit coordination drawings. Include unit details, plans, elevations, sections, details of components. Show support locations, type of support, weight and required clearances.
- E. Submit wiring diagrams including power, signal, and control wiring.

1.4 WARRANTY

- A. Annexair warrants each product to be free from defects in material and workmanship under normal and proper use, and will within twelve (12) months from date of start up and not exceed eighteen (18) months from shipment, repair or replace any part which, when returned to our factory transportation charges prepaid, and upon inspection by Annexair, proves to be defective. This warranty does not include any labor or service charges that occur under this warranty. Minimum (5) five year compressor warranty shall be provided, parts only – labor not included
- B. The installing contractor must be responsible for warranty service and maintenance after the equipment is placed into operation.
- C. NOTIFICATION: Any modification to the Annexair equipment, including the controls and sequence of operation, without specific approval in writing by Annexair, will result

in a violation of the equipment warranty

1.5 REFERENCES

All components selected for this project shall conform to the following Standards:

- A. AFBMA 9: Load Ratings and Fatigue Life for Ball Bearings
- B. AMCA Standard 99: Standards Handbook
- C. AMCA /ANSI Standard 204: Balance Quality and Vibration Levels for Fans
- D. AMCA Standard 210: Laboratory Methods of Testing Fans for Ratings
- E. AMCA Standard 300: Reverberant Room Method for Sound Testing of Fans
- F. AMCA 320; Laboratory Method for Sound Testing of Fans Using Sound Intensity
- G. AMCA Standard 500: Test Methods for Louvers, Dampers and Shutters
- H. AHRI Standard 1060: Air-to-Air Energy Recovery Ventilation Equipment
- I. AHRI Standard 410: Forced-Circulation Air-Cooling and Air-Heating Coil
- J. ASHRAE Standard 52: Gravimetric and Dust Spot Procedures for Testing Air Cleaning Devices Used in General Ventilation for Removing Particulate Matter
- K. ASHRAE 52.2: Procedures for Testing Air Cleaning Devices Used for Removing Particulate Matter
- L. ASHRAE 84-91: Method of Testing Air-to-Air Heat Exchangers
- M. ASHRAE/ANSI Standard 111: Practices for Measurement, Testing, Adjusting and Balancing of Building Heating, Ventilation, Air-Conditioning and Refrigeration Systems
- N. ASTM A-525: Specification for General Requirements for Steel Sheet, Zinc-Coated (Galvanized) by the Hot-Dip Process
- O. NEMA MG-1: National Electrical Manufacturers Association Motor Standards
- P. NFPA 90A: Standard for the Installation of Air Conditioning and Ventilating Systems
- Q. SMACNA: Sheet Metal and Air Conditioning Contractors National Association
- R. UL Standard 1995: Heating and Cooling Equipment
- S. UL Standard 900: Test Performance of Air Filter Units

1.6 COORDINATION

- A. Coordinate location and installation of air-handling units. Revise locations and elevations to suit field conditions and to ensure proper operation.
- B. Coordinate location and installation of air handling units with the electrical, mechanical, and plumbing contractors.

2. PART II – PRODUCTS

2.1 HOUSING

A. THERMO-COMPOSITE PANELS (*with thermal break frame*)

- 1. The unit housing shall be no-through metal with 2” Thermo-Composite and foam panel construction - interior and exterior Thermal break construction using a gasket to insulate two panels is not an acceptable equivalent to a no-through metal constructed casing. No-through metal construction will be

- inherent to all the component construction in the assembly.
2. All panels and access doors shall be double wall construction with R14 foam insulation for every 2" of construction. All foam insulation must be Greenguard certified®. Any insulation incorporating CFCs or HCFCs in its construction is strictly prohibited from this application.
 3. Unit casing will have no exterior condensation at interior AHU temperatures down to 43F while unit exterior conditions are maintained at 95 F dry bulb / 85 F wet bulb. The air handling unit manufacturer general construction shall be tested to demonstrate the thermal performance of the unit casing. The test shall include placing the entire test unit in a climate controlled environment and exposing the unit to the conditions mentioned previously. If the manufacturer does not have access to such equipment, an independent testing agent must be hired to transport the test unit to a qualified test facility, and perform the test at the expense of the manufacturer. Inability to provide this option to the engineer will make the manufacturer ineligible to bid on this project. The unit housing shall be constructed from a frame, base and panel assembly. Unit shall be completely factory assembled and shipped in one piece as shown on drawings.
 4. The panels shall be tested in accordance with SMACNA and ASHRAE 111 to have a deflection of no more than L/1150 at 10" and withstand air pressures up to 8" w.c with less than 1% leakage. Fire resistance of the panel will be in compliance with UL 94 rated at 5VA; and a flame spread / smoke development in compliance with UL 723 ASTM E84 Class 1 rating.
 5. Thermo-Composite or aluminum panels shall be provided for the entire unit construction, including but not limited to, walls, doors, floors, roof, interior partitions, and electrical compartment. Panels shall be non-load bearing type.
 6. The frame shall consist of anodized extruded aluminum profiles which incorporates a thermally broken construction; welded together for reinforcement and insulated for superior thermal performance.
 7. Base structure shall be fully welded G-90, painted exterior, and have integral lifting lugs which can be removed once the unit is installed.
 8. All roof and side wall seams shall be positively sealed to prevent water and air leakage. The OA and EA compartment shall have 1" PVC drains extended to exterior of unit.
 9. Access doors shall be provided to all major components to facilitate quick and easy access. Access doors will be made from the same material as the unit casing and shall incorporate thermal break construction. Fan access door(s) shall have Allegis type handles, with one handle interlinking multiple latches and threaded insert fastening handles for all remaining doors. If access doors do not open against unit operating pressure, provide safety latches that allow access doors to partially open after first handle movement and fully open after second handle movement. Removable panels provided for equipment pull out for coil(s), and air to air heat exchanger section(s) shall have key tooled threaded insert fasteners. Hinges shall be Nylon hinge type designed to open 180 degrees.

10. Unit shall have the entire exterior finished with a PVDF coating designed for UV resistance. Panels shall be painted Annexair standard color white gray RAL 9002. Panels shall pass ASTM B117 3000-hour salt fog resistance test and ASTM D4585 3000-hour moisture condensation resistance test. In addition, paint must meet AAMA 620-02 standard for color, chalking, gloss retention, and abrasion resistance.
11. The air handler unit casing shall be provided with a lifetime warranty against corrosion resistance under normal use.

B. WEATHER HOODS

The outdoor intake weather hood shall be completely constructed in aluminum for superior corrosion resistance. The hood shall ship loose for field installation by the installing contractor. Painted galvanized hoods shall not be acceptable due to its susceptibility to corrosion. The outdoor air hood shall be designed with a 4" extruded aluminum louver, bird screen and a plenum enclosure with drain holes. The louver blades shall be drainable type with a maximum 45 degree angle and curved with integral rain baffle. The louver design shall not allow more than 0.03 oz/ft² water penetration when tested in accordance to AMCA 500. The pressure drop of the complete hood assembly shall not exceed 0.05"wc at a maximum 500 fpm face velocity. A Pre-filter rack system shall be installed within the weather hood enclosure to prevent outdoor air dust and debris from entering the damper and unit casing plenum. Pre-filters installed inside the unit casing plenum and downstream of the outdoor damper will not be acceptable as this will increase overall maintenance on the damper, reduce indoor air quality and promote mold and bacteria growth. Filter access in the hood shall be accomplished via the louver that is installed with a stainless steel piano hinge and spring loaded latch. No tools or ladders shall be required to access the pre-filters in the weather hood assembly. The hood shall be insulated and header insulation constructed from 304 stainless steel shielding for increased energy efficiency and reduced airstream heat gain. Stainless steel shields to be isolated from distributor using plenum rated synthetic foam strips. Insulation to provide air-gap to minimize conduction and The unit housing

2.2 HEAT RECOVERY WHEEL

A. ENTHALPY WHEEL (SILICA GEL)

1. The enthalpy wheel shall recover both sensible and latent heat and be AHRI 1060 certified.
2. The matrix shall be a minimum of 8" thick to achieve optimal performance and be constructed from a corrugated aluminum alloy. The corrugation shall be uniform to obtain minimum pressure drops through the wheel. Wheels with varying flute sizes are not acceptable. Wheels with non-metallic matrices will not be considered for this application.

3. Wheels with varying flute sizes are not acceptable. Wheels with non-metallic matrices will not be considered for this application.
4. The media shall be specifically treated and coated with Silica Gel desiccant to assist and enhance latent heat transfer. Any other types of desiccants, including 3A or 4A Molecular Sieves will not be considered for HVAC applications.
5. A heavy duty wheel hub will contain the bearings in a closed compartment for wheel sizes up to 96" diameter. These shall be maintenance free while larger sizes require periodic lubrication. In addition, segmented wheel shall be provided on diameter sizes above 96".
6. The seal shall be made from a dual band ultra-high molecular weight polyethylene and be self-lubricating, wear resistant, and air tight against prolonged use. Seals shall be full contact compression type, on both sides of the wheel to ensure minimal leakage. Specially designed stainless steel clips are used to position the seal across the face of the wheel. Any seal that is non-contact is not to be considered a seal and will not be acceptable. Labyrinth type seals do not operate properly under different air stream pressures therefore shall not be acceptable in any circumstances.
7. Drive system shall be operated by a fractional horsepower motor (maximum 1 HP), reducing gear-box, pulley and V-belt. Belts shall be made of multi-link high-tech urethane/polyester composite. An access panel shall be provided for maintenance on the drive system. A double purge sector (2 x 5°) shall be factory installed to reduce cross contamination to under 0.04%. Frost control prevention shall be provided by the unit manufacturer and accounted for if outdoor air temperatures are below 10°F at equal airflows and return relative humidity below 30%. Frost control shall be accomplished by a variable speed drive and controlling the leaving air condition of the exhaust air. Other methods of frost control will not be considered for this application. Wheel speed shall not rotate faster than 20 RPM. Any rotational speed above 20 RPM will be unacceptable since this will reduce the efficiency of the purge section.
8. Media cleaning shall be accomplished with any of the following methods: compressed air, low pressure steam, hot water or light detergent without degrading the latent recovery

2.3 FANS

A. PLENUM FANS

1. Fans shall be direct drive radial centrifugal fans with free running impeller. No fan belts will be acceptable for this application. Fans shall be compact, optimized and construction made of galvanized sheet steel with backward curved 7-blade high efficiency impeller, protected by an epoxy powder coating.
2. To reduce vibration, the impeller shall be balanced with hub to an admissible vibration severity of less than 2.8 mm/s in conformity with DIN ISO 14694 and proof shall be supplied for each individual impeller. Tests shall be made

according to DIN ISO 1940 Part 1, quality of balancing G2.5/6.3.

3. The single inlet shall be mounted onto constant speed direct drive motor, equipped with an air flow optimized inlet cone from galvanized sheet steel.
4. Fans shall be completely certified as per ISO 5801 and in accordance to AMCA standards.

B. PLUG FANS

1. Wall mounted, direct driven plenum fans (horizontal or vertical) shall be installed with perimeter gasketed isolation.
2. Fans shall be direct drive radial centrifugal fans with free running impeller. Fans shall be compact, optimized and construction made of galvanized sheet steel with backward curved 7-blade high efficiency impeller, protected by an epoxy powder coating.
3. To reduce vibration, the impeller shall be balanced with hub to an admissible vibration severity of less than 2.8 mm/s in conformity with DIN ISO 14694 and proof shall be supplied for each individual impeller. Tests shall be made according to DIN ISO 1940 Part 1, quality of balancing G2.5/6.3.
4. The single inlet shall be mounted onto constant speed direct drive motor, equipped with an air flow optimized inlet cone from galvanized sheet steel.
5. Fans shall be completely certified as per ISO 5801 and in accordance to AMCA standards.

C. FAN ISOLATIONS

1. The fan housing and motor assembly shall be isolated from the unit cabinetry with a minimum 95% efficient spring isolators or high efficiency rubber isolators or seismic isolators.
2. In addition, fans shall have flexible canvas to reduce vibration transmission.

2.4 FAN MOTORS

- A. The fan motors shall meet NEMA standard dimensions and comply with the Energy policy Act of 1997.
- B. Motors shall have premium efficiencies with low noise and vibration output. Motors shall be certified and built in accordance to ISO 9001 quality control system
- C. Motors shall have ODP enclosure with Premium efficiency performance.
- D. Units shall be designed for **constant** application. Please refer to the unit schedule for the application type.
- E. **Option: A shaft grounding brush kit will be provided to prevent electrical damage to motor bearings by safely channeling harmful shaft currents to ground.**

2.5 VARIABLE FREQUENCY DRIVE (VFD)

- A. VFDs will be used to set or regulate the fan speed and airflow for these units.
- B. All VFD's shall be ABB model ACH550 units to match owner's existing VFD's installed at other locations.
- C. The VFD shall have PID function for constant flow applications
- D. The VFDs will be installed with integral brake transistor, overload protection, and adjustable pulse-width modulation (PWM).
- E. The VFD shall use Insulated Gate Bipolar Transistor (IGBT) technology to convert three phase input power to coded PWM output and have 4-20mA analog output terminals that are fully programmable for variable flow applications.
- F. The VFD shall be equipped with a keypad with status indicators, easy access functions, and monitoring functions during motor operation.
- G. In the event of a momentary power failure or fault the VFD shall read the inverter speed and direction of a coasting motor and shall automatically restart the motor smoothly.
- H. Technical support will be provided by the VFD manufacturer.
- I. VFDs shall be installed as shown on drawings with contactors, relays, and all specified accessories.
- J. VFDs will be installed **WITHOUT by-pass**.

2.6 FILTERS

A. PRE-FILTERS

- 1. Filters shall be factory installed upstream of the heat exchanger and coils, in both airstreams.
- 2. The filters shall be MERV 8.
- 3. Each filter shall consist of 100% synthetic media, expanded metal on the downstream and enclosing with high wet-strength beverage board with diagonal support bonded on air entering and air exiting side of each pleat.
- 4. Filters shall be placed in a completely sealed, galvanized holding frame with quick release latches for easy replacement.

2.7 DAMPERS

A. NON-INSULATED

- 1. Dampers shall be installed where shown on the drawings.
- 2. Dampers shall be low leak type with rubber edges, opposed blades, and constructed from extruded aluminum.
- 3. Galvanized dampers will not be acceptable.
- 4. The exhaust air outlet shall have a standard aluminum gravity type damper, unless otherwise noted below.
- 5. Dampers shall be installed in the compartments (as shown on the drawings)

- with linkage rod for actuators
6. Actuators shall be 24V factory installed: two-position or modulating (please refer to the unit schedule).
 7. All actuators shall have spring return mechanism and auxiliary switches. Dampers will be installed in the failed close positions unless otherwise noted

2.8 CONDENSING UNIT

A. WATER SOURCE HEAT PUMP UNIT WITH VARIABLE SPEED COMPRESSORS

1. Provide integral water source heat pump (WSHP) section(s) where indicated on the schedule. The section shall be contained in the same housing as the rest of the unit (see housing details). The WSHP shall be manufacturer by the same manufacturer as the air handling unit. Factory mounting a third parties WSHP is not acceptable. The WSHP shall be mounted within a framing system that supports all components, independent of the air handling unit casing. An access panel shall be provided to the compressors and adequate clearance shall be provided for the removal and replacement of any refrigeration component without having to remove the entire WSHP model. It is not acceptable to have to remove the unit casing or the entire WSHP module to replace any refrigeration component. The WSHP Section shall include a floor drain as a protective element to remove any water build up in the section. Exterior units shall have a pipe chase located in the same compartment as the WSHP. Pipe chases exterior to the air handling casing are not acceptable. Exterior units shall also include an auxiliary heater to provide freeze protection to the water circuit. Exterior units without auxiliary heaters are not considered adequately protected for winter conditions and will be rejected. The auxiliary heater shall be on the same electrical circuit as the unit.
2. Compressors shall be variable speed scroll type that can modulate from 30% to 100% capacity per compressor. Variable capacity compressors which do not modulate the speed of the scrolls are not considered equal to a variable speed scroll since they consume more energy at the same capacity output. Mechanically stepped scrolls which are unloaded via a digital signal to a solenoid valve, in a timed sequence, will not be acceptable for this application. The variable speed scrolls shall be operated via a factory supplied variable speed controller per compressor, and all tandem compressors will modulate in unison. Using a single variable speed controller on the lead circuit alone is not efficient during part load conditions, therefore will not be acceptable for this application. Each compressor and controller assembly shall be equipped with the following features: electronic expansion valve, reversing valve (WSHP only), a crankcase heater function, anti-short cycling, built-in phase loss detector, EMC filter, oil return management system, and reverse rotation protection. Compressors shall be mounted on rubber isolators to limit

vibration transmission and shall include a vibration eliminator conduit on both the suction and discharge refrigeration lines. Vibration eliminator conduit shall be pressure tested up to 620 psig.

3. A coaxial coil shall be provided for all water to refrigerant heat transfers. Plate type exchangers are not permitted as they require routine maintenance which is not acceptable for this application. The coaxial coil shall be copper/steel in construction and completely insulated. The refrigeration suction line shall also be completely insulated. All water connections (in and out) will be connected by the mechanical contractor. The refrigeration system shall be equipped with a factory programmed and installed controller that will modulate the system based on a 0 -10v signal. Head pressure and suction pressure control logic shall be provided on all WSHP models. Head pressure and suction pressure control is required in both cooling and heating operations to account for changes in entering water temperature. Systems that do not have head pressure control logic built into the water source heat pump or water cooled condenser shall not be considered for this application as head pressure control is considered a required safety feature. A 2-way modulating control valve shall be provided and installed by Annexair.
4. Hose kits shall be provided as ship loose items. Hose kits to include Belimo valve and actuator, automatic flow control balancing valve, strainer, isolation valve, and all necessary piping and components to provide a one inlet and outlet water connection per coaxial coil.
5. High pressure relief plug with extension to unit exterior will be provided on units where required by code.
6. The entire section shall be factory piped, wired and charged with R-410A. Each refrigeration system shall be factory tested.
7. The following components shall be included in each refrigeration circuit: Liquid line filter dryer, hi and lo pressure switch, hi and lo pressure transducers, suction and liquid lines shutoff valves and suction line accumulators. In addition, refrigeration piping must use Shrader type connections for all components, including but not limited to valves and transducers. Under no circumstances shall the units leave the factory without a complete run test and a copy of the QC report shall be provided upon request.
8. Minimum (5) five year compressor warranties shall be provided

2.9 COILS

A. DX COILS

1. Coils shall be factory installed in the unit.
2. Coils shall be designed with respective circuits to match the design requirements. All coils shall have a distributor per circuit connection. Coils shall be circuited for counter-flow heat transfer to provide maximum mean effective temperature difference for maximum heat transfer rates.

3. Primary surface shall be round seamless (3/8" O.D.) copper tube staggered in the direction of airflow. Secondary surface shall consist of rippled aluminum plate fins for higher capacity and structural strength. Fins shall have full drawn collars to provide a continuous surface cover over the entire tube for maximum heat transfer. Tubes shall be mechanically expanded into the fins to provide a continuous primary to secondary compression bond over the entire finned length for maximum heat transfer rates. Headers shall have intruded tube holes to provide a large brazing surface for maximum strength and inherent flexibility.
4. Casing shall be constructed of continuous composite/aluminum construction
5. The complete coil shall be tested with 315 pounds air pressure under warm water and be suitable for operation at 250 psig working pressures. Maximum finned coil height shall be 60" and shall not exceed 500 FPM face velocity.
6. Drain pan shall be provided on cooling coils. Cooling coils shall sit on stainless steel tubular support rails, which shall stand a minimum of (2) two inches above the highest point of the floor drain pan. Stacked coils shall be provided for larger airflows and intermediate drain pans shall be provided for each coil bank. Drain pans shall be stainless steel with 1.25" stainless steel drain connections on one side only. Pan shall be sloped in two planes.
7. All coils shall be rated in accordance with AHRI standard 410.

B. DX HOT GAS REHEAT

1. Coils shall be factory installed in the unit.
2. The hot gas reheat coil shall be installed at minimum 8" from the moisture producing DX cooling coil. A plexi glass between the two items shall be required to visually inspect the DX cooling coil surface area, and also have the ability to clean the coils when necessary.
3. A modulating valve shall be provided to control air leaving temperature for dehumidification.
4. Coils shall be designed with respective circuits to match the design requirements. Coils shall be circuited for counter-flow heat transfer to provide maximum mean effective temperature difference for maximum heat transfer rates.
5. Primary surface shall be round seamless (3/8" O.D.) copper tube staggered in the direction of airflow. Secondary surface shall consist of rippled aluminum plate fins for higher capacity and structural strength. Fins shall have full drawn collars to provide a continuous surface cover over the entire tube for maximum heat transfer. Tubes shall be mechanically expanded into the fins to provide a continuous primary to secondary compression bond over the entire finned length for maximum heat transfer rates. Headers shall have intruded tube holes to provide a large brazing surface for maximum strength and inherent flexibility.
6. Casing shall be constructed of continuous galvanized steel.
7. The complete coil shall be tested with 315 pounds air pressure under warm water and be suitable for operation at 250 psig working pressures.

8. All coils shall be rated in accordance with AHRI standard 410.

2.10 POWER AND SAFETY CONTROL

- A. The power and control center shall be integral to the unit housing and rated equivalent to NEMA 3R.
- B. Under no circumstances shall any wiring or parts be field installed. If units show up at the job site without wiring by the manufacturer, the contractor will have to send back units to the manufacturer at the contractors' expense to get them factory wired and re-tested.
- C. Panels that are externally mounted to the unit shall not be accepted, regardless of the NEMA rating they may have. A separate access door shall be provided with an approved locking device.
- D. All electrical components contained in the panel shall be UL/CSA certified and labeled. The unit shall be complete with VFDs, fuses, relays, phase protection for compressorized units, terminals for main ON/OFF and step-down transformer. All components shall be factory wired for single point power connection by the manufacturer of the unit. A non-fused safety disconnect switch shall be factory installed for ON/OFF servicing.
- E. An electrical pipe chase for power and control feeding shall be provided next to the control panel.
- F. Any power or control wiring that is field installed shall not be accepted under any circumstances. The Short Circuit Current Rating (SCCR) is 5 kA rms symmetrical, 600V Maximum or as noted on schedule.
- G. GFI, lights, and switches shall be factory installed and wired to a common junction box. A separate power connection 120V/1 will be required (powered by others).

2.11 AIR TEMPERATURE CONTROL PACKAGE

- A. The unit shall be delivered with factory installed control system. Under no circumstances shall control be provided by other than the manufacturer of the equipment. Field installed control package by the ATC will not be acceptable.
- B. The control system shall consist of a microprocessor with LCD display, 7 day time clock, 20 day holiday schedule, occupied/unoccupied mode switch, warm up mode, cool down mode, hi-lo limit discharge control, fan status, temperature and humidity sensors when applicable, scroll buttons to change settings as required and alarm history.
- C. Supply air temperature and humidity sensors shall be provided by Annexair and field mounted in the supply duct and wired by others. Optional - Space temperature and humidity wall mounted sensors shall be field wired and installed by others.
- D. Refer to the Sequence of Operation and control schematic for detailed description and options.
- E. Communication Interface Card: The microprocessor shall be capable of communicating with the following protocol language: Select one of the following:

Bacnet MS/TP RS-485.

2.12 ADDITIONAL ACCESSORIES AND UNIT FEATURES (Optional)

- A. Dirty filter switch
- B. Rotation detector (where applicable)
- C. Door interlocking switch (for fan section)
- D. Magnehelic gauges (Dwyer 2000 model)
- E. Condensate overflow switch (for drain pans)
- F. Fan Airflow Monitoring Station Package

3. PART III - EXECUTION

3.1 EXAMINATION

- A. Examine ducts, and conditions for compliance with requirements for installation tolerances and other conditions affecting performance.
- B. Examine roughing-in for piping systems to verify actual locations of piping connections before installation.
- C. Proceed with installation only after unsatisfactory conditions have been corrected.

3.2 INSTALLATION

- A. Install Air Handling Unit per manufacturers' instructions.
- B. Install with required clearance for service and maintenance.

3.3 TESTING & INSPECTION

- A. System verification testing is part of the commissioning process. Verification testing shall be performed by the Contractor and witnessed and documented by the Commissioning Authority. Refer to section 01810, Commissioning, for system verification tests and commissioning requirements.
- B. Prior to shipment, Manufacturer will provide travel costs for 2 people made up of representatives from the owner, engineer of record, and installing contractor to visit the factory and inspect the equipment after completion of manufacturing and before

shipment. Other groups can be represented, but they will be responsible for their own travel costs.

- C. Manufacturer's Field Service: Engage a factory-authorized service representative to inspect field-assembled components and equipment installation, including piping and electrical connections. Report results in writing.
 - 1. Leak Test: After installation, charge system and test for leaks. Repair leaks and retest until no leaks exist.
 - 2. Operational Test: After electrical circuitry has been energized, start units to confirm proper unit operation. Remove malfunctioning units, replace with new units, and retest.
 - 3. Test and adjust controls and safeties. Replace damaged and malfunctioning controls and equipment.

3.4 TRAINING

- A. Training of the Owner's operation and maintenance personnel is required in cooperation with the Commissioning Authority. Provide competent, factory-authorized personnel to provide instruction to operation and maintenance personnel concerning the location, operation, and troubleshooting of the installed systems. The instruction shall be scheduled in coordination with the Commissioning Authority after submission and approval of formal training plans. Refer to System Demonstrations, section 01670, for contractor training requirements. Refer to section 01810, Commissioning, for further contractor training requirements.
- B. Contact Annexair to request pricing to include factory-authorized service representative to train Owner's maintenance personnel to adjust, operate, and maintain humidifiers.
 - 1. Train Owner's maintenance personnel on procedures and schedules for starting and stopping, troubleshooting, servicing, and maintaining equipment and schedules.
 - 2. Review data in maintenance manuals. Refer to Division 1 Section "Contract Closeout."
 - 3. Review data in maintenance manuals. Refer to Division 1 Section "Operation and Maintenance Data."
 - 4. Schedule training with Owner, through Architect, with at least seven days advance notice.

END OF SECTION

BID PACKAGE – CNE Tahlequah Casino: SCOPE PACKAGE 26.02: – ELECTRICAL

Submitted by (Company Name per W-9 Form): _____

Provide the following *Lump Sum Proposal* as requested in accordance with all scope items listed in Scope of Work.

1. **BASE BID – ELECTRICAL:** \$ _____

Other Comments:

Empty box for other comments.

Contact Name: _____

Address: _____

Phone/Fax: _____

Email: _____

Signature: _____

By acknowledging items below, bidder certifies acceptance of these documents and that all associated costs have been included in the proposal amount. Any and all exceptions/comments to these documents must be attached to this proposal. Comments or requested revisions to these documents will not be accepted after this proposal date.

TERO bidders must supply a copy of TERO Certificate, front of back

Non-Collusion Affidavit

Business Relationship Affidavit

Acknowledge all scope of work items listed under scope of work (See Exhibit A)

Acknowledge Exhibits B, C, D, E, F, G, H

Addenda Included

MCC Clarifications Included

Acknowledge and agree to Foreman Manhattan Standard Subcontract Agreement/Special Terms and Conditions as per Exhibit E

Acknowledge and agree to Manhattan General Provisions as Included in the Bid Documents

SCHEDULE/EXPEDITING/SUBMITTALS
Foreman Manhattan Construction Target Schedule is attached. Please verify supplier is able to meet Foreman Manhattan required installation dates.

Sales Tax

All bids must be submitted exclusive of Federal Excise Tax and Oklahoma State Sales Tax. The Cherokee Nation is exempt from Oklahoma State Sales Tax and Federal Excise Tax under authority of § Okla. Stat. Supp. 1994 Section 1356. Bidder is to include and pay all other applicable sales tax and use taxes as required. Applications for payment shall be broken down as required by the Owner or Construction Manager.

Specific Project Requirements for the process, approval, and payment of Owner-Direct Payment Items (ODPI) are identified in section 00 60 09:

EXHIBIT “G” Tax Exempt / Owner Direct Paid Invoice (ODPI) Payment Process

Tribal Employment Rights Office.

SUBCONTRACTOR IS TO COMPLY WITH ALL CHEROKEE NATION, TRIBAL EMPLOYMENT RIGHTS OFFICE (TERO), NATIONAL INDIAN GAMING ASSOCIATION (NIGA), AND ALL BUREAU OF INDIAN AFFAIRS (BIA) RULES, REGULATIONS, AND LICENSING REQUIREMENTS INCLUDING ALL FEES AND ASSESSMENTS, ASSESSMENT, APPLICABLE TO THIS PROJECT.

11.1.1 - TERO document “An Act” Legislative Act 01-14 dated February 10, 2014.
This Document is ACT AMENDING LA 30-12, "CHEROKEE NATION EMPLOYMENT RIGHTS ACT"

11.1.2 - Subcontractors are to EXCLUDE the cost for Section; Title 40, § 1011; T.
To assess an Employee Rights Fee of one-half (1/2) of one percent (1%) on all covered contracts. This cost will be paid by the Construction Manager.

11.1.3 - The Work Permits paragraph of the Tribal Employment Rights Office (TERO) Project Labor Agreement - Master Agreement LA 01-14 states: No person who is not a member of a federally recognized tribe shall be employed by a covered employer until he or she has obtained a work permit from the TERO at a cost of twenty-five dollars (\$25) per day, per permit. Subcontractors are to INCLUDE in their proposed price for the work, all costs associated with the twenty-five (\$25) per day work permit for every non-Indian individual employed on this project.

Performance and Payment Bond Requirements: (Subcontractor contracts Only)

Costs for performance and payment bonds **shall be included in your base bid and any applicable alternates or unit prices.** All exterior envelope Bid Packages (Trades) will be required to bond. In addition, all base bids, combination base Bid and including all alternates of \$100,000 or above will require Performance and Payment Bond equal to one hundred percent (100%) of the contract amount. Reference Section 00 60 04 – Exhibit B of the C.M. Bid Manual.

No obligation shall be incurred by the Owner or Foreman Manhattan Construction Team to any Bidder by reason of the issuance of these written instructions, by any notification relating to this bid, or by any act other than the execution of a written Subcontract Agreement between Foreman Manhattan Construction Team and the Bidder.

APPLICABLE SPECIFICATIONS:

DIVISION 00 – Foreman Manhattan’s Construction Manager’s Bid Manual

Complete

BID PACKAGE 01 (March 6, 2018)

DIVISION 00 – Procurement Requirements and Contracting Requirements

00 0102 – Project Information

As Applicable

00 0105 – Geotechnical Data

As Applicable

DIVISION 01 – General Requirements

As Applicable

DIVISION 03 – Concrete

03 3000 – Cast in Place Concrete

As Applicable

DIVISION 31 – EARTHWORK

31 2000 – Earthwork

As Applicable

31 2319 – Dewatering

As Applicable

31 2500 – Erosion and Sedimentation Control

As Applicable

31 5000 – Excavation Support and Protection

As Applicable

31 6329 – Drilled Concrete Piers and Shafts

As Applicable

DIVISION 32 – SITE IMPROVEMENTS

32 9200 – Turf and Grasses

As Applicable

DIVISION 33 – UTILITIES

Section 33 5100 – Private Storm Sewer

As Applicable

Legends, Notes and Schedules per Plans and Specifications

As Applicable

Geotechnical Engineering Report by Building & Earth Sciences, Inc. dated January 17, 2018

As Applicable

BID PACKAGE 02 (March 27, 2018)

DIVISION 07 – THERMAL AND MOISTURE PROTECTION

07 1300 – Sheet Waterproofing

As Applicable

07 2100 – Thermal Insulation

As Applicable

DIVISION 22 – PLUMBING

22 1113 – Water Distribution

As Applicable

22 1313 – Private Sanitary Sewerage

As Applicable

22 1316 – Sanitary Waste and Vent Piping

As Applicable

DIVISION 23 – HEATING, VENTING, AND AIR CONDITIONING

23 6500 – Closed Circuit Cooling Tower

As Applicable

23 7313 – Central Station Air Handling Units

As Applicable

23 7313.1 – Central Station Air Handling Units

As Applicable

DIVISION 26 – ELECTRICAL

26 0519 – Low Voltage Electrical Power Conductors and Cables

Complete

26 0526 – Grounding and Bonding for Electrical Systems

Complete

26 0529 – Hangers and Supports for Electrical Systems

Complete

26 0533 – Raceways and Boxes for Electrical Systems

Complete

26 0543 – Underground Ducts and Raceways for Electrical Systems

Complete

26 0544 – Sleeves and Sleeve Seals for Electrical Raceways and Cabling

Complete

26 4113 – Lighting Protection for Structures

Complete

DIVISION 31 – EARTHWORK

31 3116 – Termite Control

As Applicable

BID PACKAGE 03 (April 16, 2018)

DIVISION 03 - CONCRETE

03 4500 PRECAST ARCHITECTURAL CONCRETE

As Applicable

DIVISION 04 - MASONRY

04 4301 STONE MASONRY VENEER DIVISION

As Applicable

05 - METALS

05 1200 STRUCTURAL STEEL FRAMING

As Applicable

05 5150 FIXED METAL LADDERS

As Applicable

DIVISION 06 - WOOD, PLASTICS, AND COMPOSITES

06 1000 ROUGH CARPENTRY

As Applicable

06 1110 WOOD BLOCKING AND CURBING

As Applicable

DIVISION 07 - THERMAL AND MOISTURE PROTECTION

07 1300 SHEET WATERPROOFING

As Applicable

07 1310 WATER REPELLENTS

As Applicable

07 2100 THERMAL INSULATION

As Applicable

07 2119 FOAMED-IN-PLACE INSULATION

As Applicable

07 2120 POLYISOCYANURATE INSULATION

As Applicable

07 2400 EXTERIOR INSULATION AND FINISH SYSTEMS

As Applicable

07 2510 FLUID APPLIED VAPOR PERMEABLE AIR BARRIER MEMBRANE

As Applicable

07 4113 METAL ROOF PANELS

As Applicable

07 4213 METAL WALL PANELS

As Applicable

07 4600 FIBER CEMENT SIDING

As Applicable

07 5200 MODIFIED BITUMINOUS MEMBRANE ROOFING

As Applicable

07 6200 SHEET METAL FLASHING AND TRIM

As Applicable

07 8100 APPLIED FIREPROOFING

As Applicable

07 8400 FIRESTOPPING

As Applicable

07 9000 JOINT SEALERS

As Applicable

DIVISION 08 - OPENINGS

08 1113 HOLLOW METAL DOORS AND FRAMES

As Applicable

08 3323 OVERHEAD COILING DOORS

As Applicable

08 4229 AUTOMATIC ENTRANCES

As Applicable

08 4233 REVOLVING DOOR ENTRANCES

As Applicable

08 4300 ALUMINUM STOREFRONT ENTRANCES

As Applicable

08 4310 ALUMINUM STOREFRONT WINDOW SYSTEMS

As Applicable

08 4400 GLAZED ALUMINUM CURTAIN WALL SYSTEMS3

As Applicable

08 7100 DOOR HARDWARE

As Applicable

08 8150 GLASS

As Applicable

DIVISION 09 – FINISHES

09 2116 GYPSUM BOARD ASSEMBLIES As Applicable
09 5100 ACOUSTICAL CEILINGS As Applicable
09 9000 PAINTINGS AND COATINGS As Applicable

DIVISION 10 – SPECIALTIES

10 2226 OPERABLE PARTITIONS As Applicable
10 7500 FLAGPOLES As Applicable
10 8200 ROOF TOP EQUIPMENT SCREENS As Applicable

DIVISION 11 - EQUIPMENT

11 1313 LOADING DOCK BUMPERS As Applicable
11 1316 LOADING DOCK SEALS AND SHELTERS As Applicable
11 1319.13 LOADING DOCK LEVELERS As Applicable

BID PACKAGE 04 (April 20, 2018)

DIVISION 32 – EXTERIOR IMPROVEMENTS

32 1216 ASPHALT PAVING As Applicable
32 1313 CONCRETE PAVING As Applicable
32 1373 CONCRETE PAVING JOINT SEALANTS As Applicable
32 1723 PAVEMENT MARKINGS As Applicable
32 3113 CHAIN LINK FENCES AND GATES As Applicable

BID PACKAGE 05 (May 3, 2018)

DIVISION 6 –WOODS, PLASTICS AND COMPOSITES

06 2000 FINISH CARPENTRY As Applicable
06 4100 ARCHITECTURAL WOOD CASEWORK As Applicable
06 8300 HIGH PRESSURE DECORATIVE LAMINATES As Applicable

DIVISION 8 –OPENINGS

08 1416 FLUSH WOOD DOORS As Applicable
08 3100 ACCESS DOORS & PANELS As Applicable
08 3313 COILING COUNTER DOORS As Applicable
08 3323 OVERHEAD COILING DOORS As Applicable

DIVISION 9 –FINISHES

09 3050 TILE As Applicable
09 6500 RESILIENT FLOORING & BASE As Applicable
09 6813 TILE CARPETING As Applicable
09 6900 ACCESS FLOORING As Applicable
09 9100 PAINTS AND COATINGS As Applicable
09 9600 RESINOUS FLOOR COATINGS As Applicable

DIVISION 10 –SPECIALTIES

10 2113.19 PLASTIC TOILET COMPARTMENTS As Applicable
10 2601 WALL AND CORNER GUARDS As Applicable
10 2615 HIGH IMPACT WALL COVERING As Applicable
10 2800 TOILET ACCESSORIES As Applicable
10 4400 FIRE PROTECTION SPECIALTIES As Applicable
10 5100 LOCKERS As Applicable

DIVISION 11 –EQUIPMENT

11 4000 FOODSERVICE EQUIPMENT As Applicable

DIVISION 22 – PLUMBING

22 05 13 COMMON MOTOR REQUIREMENTS FOR PLUMBING EQUIPMENT As Applicable
22 05 16 EXPANSION FITTINGS AND LOOPS FOR PLUMBING PIPING As Applicable
22 05 17 SLEEVES AND SLEEVE SEALS FOR PLUMBING PIPING As Applicable
22 05 18 ESCUTCHEONS FOR PLUMBING PIPING As Applicable
22 05 19 METERS AND GAGES FOR PLUMBING PIPING As Applicable
22 05 23 GENERAL-DUTY VALVES FOR PLUMBING PIPING As Applicable
22 05 29 HANGERS AND SUPPORTS FOR PLUMBING PIPING AND EQUIPMENT As Applicable
22 05 48 VIBRATION AND SEISMIC CONTROLS FOR PLUMBING PIPING AND EQUIPMENT As Applicable
22 05 53 IDENTIFICATION FOR PLUMBING PIPING AND EQUIPMENT As Applicable
22 07 16 PLUMBING EQUIPMENT INSULATION As Applicable
22 07 19 PLUMBING PIPING INSULATION As Applicable
22 08 00 COMMISSIONING OF PLUMBING SYSTEMS As Applicable
22 11 16 DOMESTIC WATER PIPING As Applicable

22 11 19 DOMESTIC WATER PIPING SPECIALITIES	As Applicable
22 11 23 DOMESTIC WATER PUMPS	As Applicable
22 13 16 SANITARY WASTE AND VENT PIPING	As Applicable
22 13 19 SANITARY WASTE PIPING SPECIALITIES	As Applicable
22 42 13.13 COMMERCIAL WATER CLOSETS	As Applicable
22 42 13.16 COMMERCIAL URINALS	As Applicable
22 42 16.13 COMMERCIAL LAVATORIES	As Applicable
22 42 16.16 COMMERCIAL SINKS	As Applicable
22 47 16 PRESSURE WATER COOLERS	As Applicable
DIVISION 23 – HEATING VENTILATING AND AIR-CONDITIONING (HVAC)	
23 00 01 HVAC GENERAL REQUIREMENTS	As Applicable
23 00 02 BASIC HVAC MATERIALS AND METHODS	As Applicable
23 05 16 PIPE EXPANSION FITTINGS AND LOOPS	As Applicable
23 05 18 ESCUTCHEONS FOR HVAC PIPING	As Applicable
23 05 19 HVAC METERS AND GAGES	As Applicable
23 05 23 VALVES	As Applicable
23 05 29 HANGERS AND SUPPORTS	As Applicable
23 05 48 HVAC VIBRATION CONTROLS	As Applicable
23 05 53 MECHANICAL IDENTIFICATION	As Applicable
23 05 93 TESTING, ADJUSTING, AND BALANCING	As Applicable
23 07 13 DUCT INSULATION	As Applicable
23 07 17 EQUIPMENT INSULATION	As Applicable
23 07 19 HVAC PIPE INSULATION	As Applicable
23 08 00 COMMISSIONING OF HVAC SYSTEMS	As Applicable
23 09 00 AUTOMATIC TEMPERATURE CONTROL SYSTEMS	As Applicable
23 09 93 SEQUENCE OF OPERATIONS	As Applicable
23 21 13 HYDRONIC PIPING	As Applicable
23 21 23 HYDRONIC PUMPS	As Applicable
23 23 00 REFRIGERANT PIPING	As Applicable
23 25 00 HVAC WATER TREATMENT	As Applicable
23 31 13 HVAC DUCTS	As Applicable
23 33 0 DUCT ACCESSORIES	As Applicable
23 34 23 HVAC POWER VENTILATORS	As Applicable
23 36 00 AIR TERMINAL UNITS	As Applicable
23 37 13 DIFFUSERS, REGISTERS, AND GRILLES	As Applicable
23 51 00 BREECHINGS, CHIMNEYS, AND STACKS	As Applicable
23 52 16 CONDENSING BOILERS	As Applicable
23 64 18.1 MODULAR CENTRAL PLANT	As Applicable
23 65 00 CLOSED CIRCUIT COOLERS	As Applicable
23 73 13 AIR-HANDLING UNIT	As Applicable
23 73 13.1 AIR HANDLING UNIT / DEDICATED OUTDOOR AIR SYSTEM / ENERGY RECOVERY UNIT	As Applicable
23 82 19 FAN -COIL UNITS	As Applicable
23 82 39 UNIT HEATERS	As Applicable
DIVISION 26 – ELECTRICAL	
26 05 19 LOW-VOLTAGE ELECTRICAL POWER CONDUCTORS AND CABLES	Complete
26 05 26 GROUNDING AND BONDING FOR ELECTRICAL SYSTEMS	Complete
26 05 29 HANGERS AND SUPPORTS FOR ELECTRICAL SYSTEMS	Complete
26 05 33 RACEWAYS AND BOXES FOR ELECTRICAL SYSTEMS	Complete
26 05 43 UNDERGROUND DUCTS AND RACEWAYS FOR ELECTRICAL SYSTEMS	Complete
26 05 44 SLEEVES AND SLEEVE SEALS FOR ELECTRICAL RACEWAYS AND CABLING	Complete
26 05 53 IDENTIFICATION FOR ELECTRICAL SYSTEMS	Complete
26 05 72 OVERCURRENT PROTECTIVE DEVICE SHORT-CIRCUIT STUDY	Complete
26 05 73 OVERCURRENT PROTECTIVE DEVICE COORDINATION STUDY	Complete
26 05 74 OVERCURRENT PROTECTIVE DEVICE ARC-FLASH STUDY	Complete
26 22 00 LOW-VOLTAGE TRANSFORMERS	Complete
26 24 13 SWITCHBOARDS	Complete
26 24 16 PANELBOARDS	Complete
26 27 26 WIRING DEVICES	Complete
26 28 13 FUSES	Complete
26 28 16 ENCLOSED SWITCHES AND CIRCUIT BREAKERS	Complete
26 29 13.03 MANUAL AND MAGNETIC MOTOR CONTROLLERS	Complete
26 32 13.13 DIESEL EMERGENCY ENGINE GENERATORS	Complete

FOREMAN | MANHATTAN

Construction Team

**CNE TAHLEQUAH CASINO
MCC Project # 3882**

26 33 53	STATIC UNINTERRUPTIBLE POWER SUPPLY	Complete
26 36 00	TRANSFER SWITCHES	Complete
26 41 13	LIGHTNING PROTECTION FOR STRUCTURES	Complete
26 51 19	LED INTERIOR LIGHTING	Complete
26 52 19	EMERGENCY AND EXIT LIGHTING	Complete
26 56 13	LIGHT POLES AND STANDARDS	Complete
26 56 19	LED EXTERIOR LIGHTING	Complete
DIVISION 28 – ELECTRONIC SAFETY AND SECURITY		
28 31 11	DIGITAL, ADDRESSABLE FIRE ALARM AND EMERGENCY COMMUNICATIONS SYSTEM	As Applicable

Terminology:

Contractor and/or Subcontractor shall mean Scope Package Bidder.

Construction Manager (CM) shall mean Foreman Manhattan Construction Team.

SCOPE OF WORK:

Includes, but is not limited to, providing all the necessary labor, materials, tools, supplies, supervision, insurance, equipment, scaffolding, hoisting, fees, etc. necessary to provide the **Electrical work** for the **CNE Tahlequah Casino**, Tahlequah, Oklahoma in accordance with the Contract Documents. It is further understood and agreed that this Subcontract also includes the furnishing and installation of the below listed items regardless of whether or not they are in the listed specification section(s) or any other specification section(s), or shown on the plans. This scope listing is to be used as a guideline and should not be considered as an all-inclusive list of items required to provide a complete scope of work under this proposal. Drawing and detail references are provided for reference only and are not to be considered as all inclusive of Contract Documents for the particular items referenced. (Please note: The word "provide" when used herein shall mean furnish and install completely, including all costs for labor, materials, equipment, hoisting, layout, scaffolding, ladders, staging, tools, rigging and any other appurtenances necessary to complete the Work".) Subcontractor has familiarized himself with the documents and has included those items of work shown and noted on the documents and all other equipment, devices and components that are not shown or noted, but required to provide a complete, functional and working system that is in compliance with all local codes.

1. Provide complete electrical and fire alarm systems including but not limited to electrical power distribution, equipment, fixtures, devices, generators and any other required electrical materials or equipment for all areas designated for construction.
2. Provide all required electrical materials and equipment including but not limited to switchboards, distribution boards, transformers, panel boards, busways, power factor control center, panel boards, circuit breakers, light fixtures, occupancy sensors, switches and receptacles.
3. Provide power for all mechanical and electrical equipment identified and/or not indicated in the contract documents. Assume installation of variable frequency drives supplied by others for all motors.
4. Subcontractor shall provide all electrical power requirements for equipment furnished under another Specification Sections, including but not limited to, the following items. This work includes all conduit, wiring, junction boxes, disconnects, etc. as required for complete power supply to the equipment.
 - A. Electric operated door hardware.
 - B. Signage
 - C. Audio Video
 - D. Voice and data
 - E. Gaming power including casino floor junction boxes
 - F. Food service equipment.
 - G. Plumbing equipment
 - H. Fire Protection equipment
 - I. Heating, Ventilating and Cooling equipment.
5. Provide complete Digital, Addressable Fire alarm and Emergency Communications System as indicated in section 283111 and the contract documents.
6. Provide underground electrical systems as indicated including all required excavation, bedding and back-fill of systems.
7. Provide all pumping of water in Subcontractor's excavations/trenches as required for the work of this Subcontract.
8. Provide all electrical work for the site power and site lighting identified on sheet ES1.0 of the contract documents.
9. Provide electrical power connections and lighting for all site signage. Provide empty raceway for data connections if necessary for site signs.
10. Provide all electrical work for the exterior CCTV Infrastructure identified on sheet ES1.0A of the contract documents.
11. Provide all light fixtures indicated within the contract documents including lamps.
12. **Provide complete lighting systems including all site lighting, interior lighting, exterior building lighting, light fixtures, and lamps as per the contract documents.**
13. **Provide unloading, receiving, inventory control, installation and lamping for all decorative light fixtures where identified in the Interior Design Documents to be provided by Specialty Vendors and/or The Owner. Provide lamping materials and installation for the specialty light fixtures.**
14. Conduit routing described in the basis of design documents is to be reviewed as general in nature and should not be used for exact quantity. Subcontractor shall participate in a formal coordination process with other subcontractors (primarily the Mechanical, Plumbing and Fire Protection Trades) in order to determine the final routing for all systems. Foreman Manhattan, nor the design team, will be providing models for use by Subcontractors.
15. Provide power connections for electric unit heaters, electric cabinet heaters and electric duct heaters.
16. Provide loose disconnects, motor starters (other than VFD's) and combination motor starter/disconnect switches for electrical, plumbing, mechanical and fire protection equipment. Coordinate sizing with the corresponding subcontractor.
17. Provide installation of Variable frequency drives / variable speed drives (supplied by others) for all equipment.
18. Provide electrical power rough-in and final power connections for all equipment requiring power for other trades whether explicitly shown in the electrical drawings or not. Provide review and updating electrical requirements of other trades and documenting any changes or revisions to the contract documents.
19. Provide emergency generators and automatic transfer switches as indicated. Provide silencer for generator to be installed by the mechanical contractor unless integral to the equipment. Provide generator load testing, start-up and burn-in including fuel and re-fueling for a full tank after testing.
20. Provide fire alarm and interlock wiring connections for fire dampers, combined fire/dampers, duct detectors, coiling doors, fire shutters and any other devices requiring a Fire Alarm Monitoring point.
21. Provide all duct mounted smoke detectors to the mechanical contractor for installation. Provide all raceway and final connections to the fire alarm system.

22. Provide fire alarm system connections to all sprinkler control valves and tamper switches throughout the building.
23. **Provide raceway/conduit systems as required by code, in-wall, above in-accessible ceilings or as required for all fire alarm, telecommunications, gaming data, slot signage, digital signage, security, surveillance, and audio/visual systems.**
24. Provide a complete lighting protection system including all ground bars and distribution throughout the building.
25. Provide a complete temporary electrical service during construction to supply the building and any other construction equipment with power including but not limited all existing interface and connection, temporary feeders, underground conduits, disconnect switches and panel boards required. This subcontract should include temporary meters as required for electrical consumption monitoring. Once permanent power is energized, this subcontract shall provide demolition and removal of all temporary services, wire removal from the underground conduits and removal of all temporary panel boards and disconnects.
26. Provide temporary power and lighting distribution throughout the construction areas for use during construction including but not limited to temporary panels on each floor of the building with a minimum of 4x20amp quad outlets with GFCI protection or as required by OSHA and temporary lighting for all floors as required by OSHA standards. Include removal of all temporary systems as permanent systems are energized.
27. Provide all required fire stops, firesafing, fire caulking, sealing and grouting of all floor, wall and ceiling penetrations as required by this scope of work.
28. Provide assistance with start-up, and all testing and balancing of equipment and mechanical systems.
29. Provide all performance and acceptance testing. Subcontractor to provide all labor, materials, supervision and equipment to facilitate the testing of all work of this subcontract.
30. Provide commissioning of new systems as indicated.
31. Provide all necessary local and state trade permits, test and inspection fees as required for the performance of this subcontractor's work.
32. Provide all required roof curbs, supports, flashings, flashing collars, water seals, escutcheons and counter flashings as required for all equipment mounted on the roofs and mechanical roof penetrations.
33. Provide all miscellaneous metal and steel items for support of mechanical items of work including but not limited to hangers, protective appurtenances, platforms, plates, sleeves, embedded items, unistrut, bolts, rods and straps. All embedded items such as sleeves, thimbles, inserts, anchor bolts, and steel plates are required to be installed on the concrete framing at least 3 days prior to the schedule concrete pour.
34. Provide all required vibration isolation for all installation equipment and piping.
35. Provide all required expansion and building movement isolation / expansion equipment or materials required based on the structural area separations for different areas of construction.
36. Provide caulking and sealing of all work provided by this subcontract. Include escutcheons and/or finish caulking of all materials in exposed areas to adjacent surfaces.
37. Provide training for all systems, components and equipment for the owner's building operations team.
38. Provide labels, stencils, tags, warning tape and similar pipe identification relative to the work of this subcontract.
39. Provide touch-up painting of any damaged pre-finished equipment.
40. Provide all required access panels or architectural cover plates as required for the execution of this work (All access panels will be installed by the ceiling or wall contractor).
41. Provide all required sleeves or block-outs in slabs required for this scope of work. All slab penetrations shall be coordinated with the design team and Foreman Manhattan in a timely manner to allow fabrication and installation of all required reinforcing steel needed for these openings.
42. Provide all cutting, patching and repair of concrete, drywall and masonry if Subcontractor's work is not installed ahead of other trades. All costs to cut/patch/repair this work will be borne by this Subcontractor.
43. Concrete pads and bases will be provided by others. Subcontractor shall provide the coordination and layout for all concrete pads, bases and curbs. Subcontractor will furnish any required sleeves, block outs, anchors, or other embedment.
44. Provide extended manufacturer's warranties for equipment required to be used during construction to extend the warranty start date to the date of substantial completion for the project.

GENERAL ITEMS

1. Include separate mobilizations / demobilizations as required by the Project Schedule and Phasing Plans.
2. Provide all shop drawings, product data, sample and other pertinent submittals for the work of this Subcontract. Provide engineering and printing costs for all shop drawings, coordination drawings, and product submittals for architect approval as required to properly coordinate the work included in this Subcontract with other trades. Include costs for revising and resubmitting shop/ coordination drawings as needed.
3. Subcontractor will assist Foreman Manhattan with providing material quantities and cost breakdowns as required for the Owner's and Foreman Manhattan's budget requirements. All breakouts specified in this subcontract will be used for accounting purposes and tracking only.
4. Contractor shall provide a complete installation that complies with all applicable codes, ordinances and satisfying all Authorities Having Jurisdiction.
5. Provide all field engineering and layout from benchmarks and base building control (benchmarks and baseline control is furnished by others). This Subcontractor is responsible for replacement of any damaged benchmarks, base line control or layout work of other trades/packages damaged or destroyed by the work of this work package.
6. Provide all required pedestrian protection, traffic control and protection including flagman, barricades, signage, etc. as required for the work, and as may be required for protection for equipment access, deliveries and loading.
7. Subcontractor is required to comply with requirements to control Dust and Airborne Contaminants. No waste materials or debris shall be allowed to accumulate.

8. Provide coordination, assistance, and necessary access for the Owner's furnished Testing Laboratory, including notification, obtaining samples and data gathering as required for scope of work. Costs for retesting due to failed tests and/or for Subcontractor's unpreparedness, will be paid by this Subcontractor.
9. It is mutually understood and agreed that this subcontractor will coordinate all of the scheduled deliveries of these items being furnished by others with the Foreman Manhattan designated representative. This includes the on or off site storage, staging, inventory control, and shipping to the site. All damages or shortages are to be reported within 24 hours of delivery.
10. Subcontractor agrees to be bound by the Welcome Package issued by the Foreman Manhattan Field staff.
11. **Revise paragraph 1.2.3 of section 00 60 02A Manhattan General Provisions as contained in the Construction Manager's Bid manual as follows:**
Until Subcontractor's obligations under this Subcontract are completely fulfilled, Subcontractor agrees not to perform any changes to the work directly for Owner or any of its tenants, or deal directly with Owner's representatives with respect to the work and/or changes to the work, in connection with the Project, unless approved in writing by Foreman Manhattan. Foreman Manhattan understands that the Owner and specifically TERO shall communicate directly with the subcontractor to maintain a spirit of cooperation and also to utilize the TERO Job Bank to the fullest extent giving first hire priority rights to Cherokee Citizens.
12. **The Owner requirements for funding for work in progress is to provide payment less retainage of ten percent (10%), which shall be withheld and paid, without interest, upon final completion of the entire project.**
13. The terms and conditions contained in the following documents including General Provisions, Article 2.5, "Indemnification" as included within the contract documents; are incorporated herein by reference as if fully written out;
 - Foreman Manhattan General Provisions 2012
 - Exhibit A – (Scope of Work)
 - Exhibit B – (Bond Forms)
 - Exhibit C – (Insurance Requirements / Sample)
 - Exhibit D – (Contract Documents)
 - Exhibit E – (Special Conditions)
 - Exhibit F – (Project Schedule)
 - Exhibit G – Tax Exempt – O.D.P.I.
 - Exhibit H – (Foreman Manhattan Additional Safety Requirements)

SCOPE OF WORK EXCLUSIONS:

The following items are excluded from this Subcontract:

1. Concrete housekeeping pads and bases.
2. Maintenance Building
3. Painting
4. Cost of Dumpsters.
5. Temperature Control wiring.
6. Concrete housekeeping pads.
7. Concrete work for Site Lighting Pole Bases.
8. **Work that is provided by separate under slab subcontract; the underground and under-floor ducts and raceways, complete. (all conductors for these raceways shall be provided by this BP 26.02 Subcontract)**
9. **Work that is provided by separate under slab subcontract; under slab empty electrical conduits with 6" stub ups at each end as shown on electrical drawings; including but not limited to: (all conductors for the following raceways shall be provided by this BP 26.02 Subcontract)**
 - a) E1.1: 1-1/4" under slab conduit from Service Station 18 to panel 'TCSP5' (Room 36 Electrical)
 - b) E 1.1: 1" under slab conduit at Lounge 16.
 - c) EFS112: Sheet Notes 1 and 2, under slab conduits as noted in the Kitchen
 - d) EFS113: Sheet Notes 1 and 2, under slab conduits as noted in the Kitchen
 - e) EFS115: Sheet Notes 1, under slab conduits as noted in the Kitchen
 - f) ES1.0A: 4 inch under slab conduit from 5' outside the building IMF Room, stub up 8" AFF
10. **Work that is provided by separate under slab subcontract; all required underground / under slab sleeves, Raceways, and conduits required at the Fire Riser Room 34, Emergency Electrical 35, Electrical Room 36 and outdoor equipment yard. (all conductors for these raceways shall be provided by this BP 26.02 Subcontract)**
11. **Work that is provided by separate under slab subcontract; the Two (2ea) conduits, plus Two (2ea) Spare Conduits, for a total of Four (4ea) 2 inch conduits from Main Service Switchboard 'TCMSA' location, straight West under the building slab, to stub up 5' outside the building on the west face, near the circle drive. These conduits will serve the entry signs (not in this bid package), and other exterior building components. Ref Sheet ES1.0. (all conductors for these raceways shall be provided by this BP 26.02 Subcontract)**
12. **Work that is provided by separate under slab subcontract; the Secondary Electrical Extension from the main service switchboard location to the Maintenance Building, complete by this subcontractor. Ref C2.02b, Utility Plan Keynotes, Item 2.10e. Provide all raceways, conductors for a complete system. Note: Primary Electric Extension to be completed by Electrical Service Provider (not in this Contractor's Scope). (all conductors for these raceways shall be provided by this BP 26.02 Subcontract)**

13. **Work that is provided by separate under slab subcontract;** the exterior site TELECOMM raceway/conduits shown on sheet 2.02b and identified by Utility Plan Keynotes, Items 2.80a through 2.80e. **(all permanent cable and/or fiber and terminations for these raceways shall be provided by a separate Low Voltage Data Provider)**
14. **Work that is provided by separate under slab subcontract;** under slab conduits shown on ITS101 and ITS 102 Low Voltage Conduit Plans. **(all conductors for electrical power for these raceways shall be provided by this BP 26.02 Subcontract)**

FOREMAN | MANHATTAN
Construction Team

**SUBCONTRACT
AGREEMENT
FORMS**

SUBCONTRACT
PROJECT NUMBER: **3882**

Date: _____
Project Name: _____

Address: _____

Cost Code: _____

Subcontractor: _____
Attn: _____
Address: _____

Telephone No: _____ Fax No: _____
Email: _____

1. Subcontractor shall perform all work and furnish and pay for all supervision, labor, materials, plans, scaffolding, tools, equipment, supplies, and anything else necessary for the construction and completion of all work described in Exhibit A, and all work incidental thereto or reasonably inferable therefrom, in strict accordance and in full compliance with the terms of the Contract Documents, as defined and described in Exhibit A (all of which is hereinafter referred to as the "Work").
2. Foreman Manhattan Construction Team shall pay Contractor, for the performance of the Work, subject to additions and deductions by change order or other Subcontract provisions, the total sum of _____ Dollars (\$ _____), Including sales tax.
3. Applications for payment shall be submitted monthly on a date to be determined by Foreman Manhattan. Payments shall be made to Contractor within five (5) working days of receipt of payment from Owner subject to the terms and conditions contained in the Manhattan General Provisions.
4. Payment and performance bonds are required in a form attached as Exhibit B. If paid by Foreman Manhattan, bond amount shall not exceed \$0.00.
5. Retainage shall be withheld from each pay application in the amount of _____%.
6. Subcontractor must furnish a certificate of insurance in accordance with Foreman Manhattan's Subcontractor's Minimum Insurance Requirements attached as Exhibit C and obtain all required insurance prior to commencing its work.
7. The terms and conditions contained in the following documents, including General Provisions - Article 2.5, Indemnification, which are attached hereto, are incorporated herein by reference as if fully written out:

Manhattan General Provisions	Pages 1 through <u>18</u> with 5-page Insurance Rider (Signed XX.XX.XXXX) 1-page Oklahoma Rider (Signed XX.XX.XXXX)
Exhibit A (Scope of Work)	Pages 1 through <u>4</u>
Exhibit B (Payment and Performance Bond Form)	Page 1
Exhibit C (Insurance Requirements/Sample)	Pages 1 and 2
Exhibit D (Contract Documents)	Pages 1 through <u>2</u>
Exhibit E (Special Conditions of Subcontract)	Pages 1 through <u>2</u>
Exhibit F (Project Schedule)	Pages 1 through <u>3</u>
Exhibit G (FMC Additional Safety Requirements)	Page 1

"Subcontractor"
SUBCONTRACTOR COMPANY NAME

"Foreman Manhattan"
FOREMAN MANHATTAN CONSTRUCTION TEAM

Signature

Printed Name

Title

Date: _____

Signature

Printed Name

Title

Date: _____

Subcontractor ABC
1234 N. ABC Drive, Generic Location, OK
Phone: xxx.xxx.xxxx Fax: xxx.xxx.xxxx
MANHATTAN GENERAL PROVISIONS
Dated 01/13/2015

ARTICLE 1
CONTRACT DOCUMENTS

1.1 DEFINITION

1.1.1 The Contract Documents consist of the Subcontract, the Agreement between Manhattan and Owner (“Agreement”), Conditions of the Contract (General, Supplementary and other Conditions), Drawings, Specifications, Addenda issued prior to the execution of the Agreement, the Manhattan General Provisions, other documents listed in the Subcontract and the Manhattan General Provisions (including Exhibits and Riders) and all modifications issued after execution of the Agreement.

1.1.2 Subcontractor acknowledges and agrees that its Subcontract and the Contract Documents are adequate and sufficient to provide for the performance and completion of the Work, and include all work, whether or not shown or specified, which reasonably may be inferred to be required for the completion of the Work in accordance with all applicable laws, codes and professional standards.

1.1.3 The Contract Documents (except for proprietary and financial terms) shall be made available for inspection by Subcontractor at a reasonable time and upon reasonable notice in order to ascertain all the obligations which Manhattan has assumed toward Owner and which Subcontractor assumes to Manhattan, as provided below.

1.2 THE SUBCONTRACT

1.2.1 The Subcontract represents the entire and integrated agreement between the parties and supersedes all prior negotiations, representations or agreements, whether written or oral.

1.2.2 The Subcontract may not be construed to create any contractual relationship of any kind between Subcontractor and Owner, between Subcontractor and Architect or between any persons or entities other than Manhattan and Subcontractor. Notwithstanding the above, Manhattan's surety (or sureties) is an intended beneficiary of the Subcontract.

1.2.3 Until Subcontractor's obligations under this Subcontract are completely fulfilled, Subcontractor agrees not to perform any work directly for Owner or any of its tenants, or deal directly with Owner's representatives, in connection with the Project, unless approved in writing by Manhattan.

1.2.4 With respect to the work covered by this Subcontract, Subcontractor shall assume all obligations, risks and responsibilities to Manhattan which Manhattan has assumed toward Owner and Manhattan shall have all rights and remedies with respect to Subcontractor as Owner has with respect to Manhattan, in the Contract Documents, except to the extent the Subcontract requires more of the Subcontractor or gives Manhattan greater rights.

1.3 THE WORK

The Work of Subcontractor shall include the performing and furnishing by Subcontractor of all supervision, labor, materials, services, scaffolding, hoisting, tools, equipment, supplies, systems, machinery, transportation, apparatus, drawings, shop drawings, samples, mock-ups, submittals, plans, job hazard analysis and all other things necessary for the construction and completion of the Work, as described in its Subcontract, and all Work incidental thereto or reasonably inferable therefrom, in strict accordance and in full compliance with the terms of the Contract Documents.

1.4 PARTICULARIZED TERMS

Unless the context of these provisions indicate otherwise, or as otherwise provided,

(a) The term “days” shall mean calendar days.

(b) The term “contractor” appearing in any of the Specification Sections or Divisions applicable to the Subcontract shall mean Subcontractor unless specifically stated otherwise herein.

(c) The term “subcontractor” shall mean any subcontractor, vendor or materialman, of any tier to Subcontractor, which is supplying material or performing work in connection with the Work required in the Subcontract.

(d) The term "subcontract" when referencing contractual arrangements between subcontractors and Subcontractor shall mean purchase orders and contracts for construction, materials and/or services relating to the Work.

(e) References to "Owner" shall include the Owner, its Architects and other representatives acting on their behalf.

1.5 INTERPRETATION OF CONTRACT DOCUMENTS

1.5.1 It is the intention of the parties that all the terms of the Subcontract are to be considered as complimentary. However, in the event that such an interpretation is not possible, the order of precedence of the documents forming this Subcontract shall be (a) modifications of any documents forming part of the Subcontract; (b) the Subcontract, including attached Exhibits and Riders (unless the Manhattan General Provisions or the Contract Documents impose a higher standard or greater requirement on the Subcontractor, in which case the Manhattan General Provisions or the Contract Documents shall govern); (c) the Manhattan General Provisions (unless the provisions of (b) apply), and (d) the Contract Documents (unless the provisions of (b) apply.)

1.5.2 In the event of a conflict between or among modifications, the later in date shall prevail; in the event of a conflict between or among the terms of the Subcontract, the higher standard or greater requirement for Subcontractor shall prevail.

ARTICLE 2 **SUBCONTRACTOR**

2.1 SUBCONTRACTOR'S INVESTIGATIONS AND REPRESENTATIONS

2.1.1 Subcontractor represents that it has studied and compared the Contract Documents with each other, and will continue to study and compare any revisions to the Contract Documents, for the purpose of discovering errors, inconsistencies or omissions in the Contract Documents as it concerns the scope of Subcontractor's Work. This review by Subcontractor is in Subcontractor's capacity as a contractor, and not as a designer, unless the scope of Subcontractor's Work includes design responsibilities. Subcontractor shall be liable for any damage resulting from such errors, inconsistencies or omissions if Subcontractor discovered, or should have discovered, such errors, inconsistencies or omissions. With respect to errors, inconsistencies or omissions that Subcontractor did not discover and which it could not, with reasonable diligence, have discovered, Subcontractor shall notify Manhattan as provided in Paragraph 3.2 herein following the discovery of such errors, inconsistencies or omissions or any claims based upon errors, inconsistencies or omissions shall be deemed waived. Nothing herein shall bar Subcontractor's right, if any, to seek additional compensation if allowed under the Subcontract assuming timely notice is received.

2.1.2 Subcontractor represents that it is fully qualified to perform this Subcontract, and acknowledges that prior to the execution of this Subcontract it has (a) by its own independent investigation ascertained and evaluated (i) the Work required by this Subcontract, (ii) the conditions and difficulties involved in performing the Work, (iii) the obligations of this Subcontract and the Contract Documents, (iv) the nature, locality and site of the Work, (v) climatic conditions, and (vi) the availability and costs of labor and materials, tools and equipment and (b) verified all information furnished by Manhattan or others, satisfying itself as to the correctness and accuracy of that information. Any failure by Subcontractor to investigate independently and become fully informed will not relieve Subcontractor from its responsibilities hereunder. Subcontractor assumes the risk of any increases in its labor, materials, fuel or any other thing necessary for the construction and completion of the Project, whether foreseen or unforeseen. Subcontractor shall be entitled to additional compensation for price escalations to the extent Manhattan is entitled to recover and actually recovers such additional compensation from Owner.

2.2 TIME OF PERFORMANCE

2.2.1 Subcontractor will proceed with the Work in a prompt and diligent manner, in accordance with Manhattan's schedules, as reasonably amended from time to time. Subcontractor shall be liable to Manhattan for failure to adhere to Manhattan's schedule, including amendments, even if such schedules differ from schedules set forth in the Contract Documents or the time of completion called for by the Contract Documents. TIME IS OF THE ESSENCE. In agreeing to perform the Work in accordance herewith, Subcontractor has taken into account and made allowance for delays which should be reasonably anticipated or foreseeable.

2.2.2 Subcontractor shall notify Manhattan in writing of any objection to any schedule or amendment thereof, within forty-eight (48) hours after receipt of such schedule or amendment. The failure by Subcontractor to object to any schedule or amendment shall constitute acceptance and waiver of any claim of Subcontractor based on any schedule or amendment to the schedule.

2.2.3 If requested by Manhattan, Subcontractor shall submit detailed schedules for performance of the Subcontract, in a form acceptable to Manhattan, which shall comply with all scheduling requirements of the Contract Documents and of Paragraph 2.2.1 above. Manhattan may from time to time, at its sole discretion, direct Subcontractor to make reasonable modifications and revisions in such schedules.

2.2.4 Subcontractor agrees to accelerate its work and work overtime, if necessary, to bring its work back on schedule. Subcontractor shall not be entitled to additional compensation for this acceleration if Subcontractor is late in the performance of the work or is not otherwise entitled to an extension of time. Subcontractor agrees to coordinate its Work with the work of Manhattan, Manhattan's other subcontractors, and Owner's other contractors, if any, so no delays or interference will occur in completion of any part and/or all of the Project. All float in Manhattan's schedule shall belong to Manhattan.

2.2.5 Provided that Manhattan has not actively interfered with Subcontractor's performance, causing a delay on the critical path of the project schedule, Subcontractor expressly agrees not to make, and hereby waives any claim for damages (including but not limited to those resulting from increased labor or material costs, acceleration, disruption, inefficiency, loss of productivity, impacts, or extended general conditions costs) (hereinafter "Disruption Damage") on account of any delay, obstruction or hindrance from any cause whatsoever, whether or not foreseeable and whether or not anticipated, and agrees that the sole right and remedy for any such delays and impacts of any kind shall be an extension of time as provided below. Notwithstanding the above, Subcontractor shall be entitled to additional compensation for Disruption Damage to the extent, but only to the extent, that Manhattan actually recovers damages from Owner which includes damages incurred by Subcontractor. Subcontractor agrees that Manhattan shall not be deemed to have actively interfered with Subcontractor's work based on the exercise of legal remedies available in the subcontract to Manhattan or by the number or amount of any changes to this Subcontract.

2.2.6 Subcontractor shall be entitled to an extension of time only to the extent Manhattan obtains an extension of time from Owner, as it pertains to Subcontractor's work and only if Subcontractor has properly notified Manhattan of its claim for an extension of time as required by the Contract Documents and this Subcontract.

2.3 WARRANTY

2.3.1 Subcontractor warrants to Manhattan, Owner and Architect that all materials and equipment furnished under the Subcontract will be new unless otherwise specified, and that all Work will be of the quality required by the drawings and specifications, free from faults and defects and in conformance with the Contract Documents. Subcontractor warrants that it and its subcontractors will perform their work and will manufacture and furnish material and equipment in a good and workmanlike manner.

2.3.2 Subcontractor further warrants its Work, materials and equipment hereunder to Manhattan on the same terms, and for the same period, as Manhattan warrants the Work to Owner under the Contract Documents.

2.3.3 Subcontractor additionally agrees to repair or replace all Work that may prove defective in workmanship or materials commencing on the date of substantial completion and ending one year from the date of completion and acceptance of the Work by Owner in addition to any requirements in the Contract Documents to repair or replace defective Work. Such guarantees and warranties shall include the removal and replacement of other work affected thereby and payment for resulting damage to other property.

2.3.4 The warranties and guarantees provided in this Section 2.3 are in addition to, and not in limitation of, any other right or remedy Manhattan may have or any other warranty given by Subcontractor, and will not limit any recovery Manhattan may seek or any remedy of Manhattan under the Subcontract, or as provided by law, including the recovery of direct or consequential damages. Specifically, and not by limitation, the express warranty provided by Subcontractor and its subcontractors will not limit, in any respect, any implied warranties at law which may apply to Subcontractors Work, including a warranty for the quality of labor and materials and a warranty of good and workmanlike performance.

2.4 SUBCONTRACTOR'S LIABILITY

2.4.1 Subcontractor shall have responsibility and liability for all Work, supervision, labor and materials provided hereunder, whether or not erected in place, and for all plant, scaffolding, tools, equipment, supplies and other things provided by Subcontractor until final acceptance of the Work by Owner, and shall at all times prosecute the Work in a good and workmanlike manner, with diligence and continuity. In the event of any loss, damage or destruction thereof from any cause, Subcontractor shall be liable therefore, and shall repair, rebuild and make good said loss, damage or destruction at Subcontractor's cost. Nothing herein shall prejudice any rights Subcontractor may have to recover its costs from any applicable Builder's Risk policy which may provide coverage for said loss.

2.4.2 Subcontractor shall be liable to Manhattan for all costs Manhattan incurs or becomes responsible for as a result of Subcontractor's failure to perform this Subcontract, or any other subcontract between Manhattan and Subcontractor, in accordance with their terms. The breach of any provision of any other subcontract between Subcontractor and Manhattan shall, at Manhattan's election, constitute a breach of this Subcontract and a breach of this Subcontract shall constitute a breach of any other subcontract between Manhattan and Subcontractor on any other project. Manhattan shall be entitled to offset, against any amounts due Subcontractor, any amounts due Manhattan from Subcontractor on any other project. Subcontractor's failure to perform shall include the failure of its subcontractors to perform. Subcontractor's liability shall include but not be limited to (a) damages and other delay costs payable by Manhattan to Owner (including liquidated damages); (b) Manhattan's or its agent's or its other subcontractor's, and

supplier's increased costs of performance, such as extended overhead and increased performance costs resulting from delays or improper Work; (c) warranty and rework costs; (d) liability to third parties; (e) excess procurement costs; (f) consultants' fees; and (g) attorneys' fees and related costs.

2.4.3. Without limiting the foregoing, if Subcontractor is only furnishing labor for the finishing, installation or erection of materials furnished by Manhattan, the following costs, without restriction thereto, are to be fully recovered by Manhattan from Subcontractor: (a) the full cost of materials required to replace those spoiled by Subcontractor through faulty workmanship or negligence or damaged by any other cause not the fault of Manhattan; (b) the full cost of materials wasted by Subcontractor; (c) the full cost of removing rejected materials when not properly and promptly removed by Subcontractor, together with cost of removing, patching or replacing the work of others necessitated by such rejection; (d) the full cost of reworking, refinishing or altering any work of Subcontractor not accepted by Owner or the Owner's authorized agents; and (e) cost resulting from damage by Subcontractor to materials or work of Manhattan or others.

2.4.4 In the event that Subcontractor or any of its agents, employees, suppliers, or subcontractors utilize any machinery, equipment, tools, scaffolding, hoists, lifts or similar items belonging to or under the control of Manhattan, Subcontractor shall be liable to and shall defend and indemnify Manhattan for any loss or damage (including bodily injury, personal injury, death or property damage) which may arise or result from such use, except when such loss or damage is due solely to the negligence of Manhattan employees operating Manhattan-owned or Manhattan-leased equipment. **SUBCONTRACTOR EXPRESSLY ASSUMES LIABILITY FOR THE CONCURRENT NEGLIGENCE OF MANHATTAN; HOWEVER, THIS LIABILITY SHALL BE LIMITED AS PROVIDED IN PARAGRAPH 2.5.2 BELOW.**

2.4.5 Subcontractor agrees to assume entire responsibility and liability for any claim or action based on or arising out of injuries, including death, to persons or damages to or destruction of property (real, personal, tangible or intangible) sustained in connection with the performance of this contract by Subcontractor, its subcontractors, agents and employees. **THIS RESPONSIBILITY AND LIABILITY OF SUBCONTRACTOR APPLIES EVEN THOUGH THE CLAIM OR ACTION IS THE RESULT OF THE CONCURRENT NEGLIGENCE OF MANHATTAN, OWNER, ARCHITECT, THEIR REPRESENTATIVES OR THEIR EMPLOYEES, AGENTS, INVITEES OR LICENSEES THEREOF TO THE EXTENT LIABILITY FOR CONCURRENT NEGLIGENCE OF THE ABOVE-REFERENCED PARTIES IS ALLOWED BY APPLICABLE LAW.**

2.4.6 Subcontractor's assumption of liability is independent from, and not limited in any manner by, the insurance required of Subcontractor. All amounts owed by Subcontractor to Manhattan as a result of the liability provisions of this Subcontract shall be paid upon demand.

2.5 INDEMNIFICATION

2.5.1 To the fullest extent permitted by law, Subcontractor is liable for and will defend, indemnify, hold harmless and reimburse Manhattan, its surety, Owner, Architect (and any other design professionals retained by either Owner or Architect), all other persons or entities for which indemnity is required by the Contract Documents and their representatives and employees, officers, agents, invitees and licensees of the same (collectively "Indemnitees"), against:

(a) all claims arising out of any breach of this Subcontract by the Subcontractor, or a breach of any agreement relating to the Work or any Work done by any of its subcontractors, or any negligent act, gross negligence, error or omission by Subcontractor or any of its subcontractors, or any patent or copyright infringement arising out of the performance of this Subcontract by Subcontractor or any of its subcontractors;

(b) all liabilities, claims and demands for personal or bodily injury (including death) or property damage (real, personal, tangible or intangible) to any of the Work of Subcontractor or any other work or property of any other party, including injury or death to Subcontractor's employees, together with any resulting costs, legal fees and consulting fees, arising out of or caused by any act or omission of the Subcontractor or any of its subcontractors, their agents or employees;

(c) all liens, or claims of rights to enforce liens, against the Project, Project Site and all claims against Manhattan or its surety arising out of any work performed or to be performed or labor, services or materials furnished or to be furnished under this Subcontract by any of its subcontractors to Subcontractor;

(d) all costs, damage, expenses and liabilities Indemnitees may sustain by reason of the failure of Subcontractor to indemnify any of the Indemnitees as required herein and elsewhere in the Subcontract; and

(e) all other costs, damage, expenses and liabilities (including all resulting costs, legal fees and consultant fees) for which Manhattan is liable to Owner under its Agreement, or to any third party under agreements with those third parties who may be affected by construction of the Project on account of or in any way related to Subcontractor's Work.

2.5.2 THE ABOVE-REFERENCED DEFENSE AND INDEMNIFICATION OBLIGATION SHALL APPLY EVEN THOUGH THE MATTER IS THE RESULT OF THE CONCURRENT NEGLIGENCE OF ANY OR ALL OF THE INDEMNITEES (INCLUDING OTHER SUBCONTRACTORS OF MANHATTAN) TO THE EXTENT (A) THE CLAIM INVOLVES BODILY INJURY OR DEATH OF AN EMPLOYEE OF SUBCONTRACTOR, ITS AGENTS OR ANY OF ITS SUBCONTRACTORS OF ANY TIER OR (B) APPLICABLE LAW ALLOWS DEFENSE AND INDEMNITY FOR CONCURRENT NEGLIGENCE OF THE INDEMNITEES FOR OTHER CLAIMS FOR DAMAGES OR INJURY TO PERSONS OR PROPERTY IN ADDITION TO THOSE SET FORTH IN SUBPART (A) ABOVE.

2.5.3 Manhattan has a right to withhold from any payments due or to become due Subcontractor an amount which, in Manhattan's opinion is reasonable to protect Manhattan from any claims or lawsuits subject to this indemnification paragraph. These rights are in addition to Manhattan's other legal and equitable rights. The indemnification obligation under this provision and this Subcontract, or any other indemnification obligation under any other subparagraph of this Subcontract, are not limited by a limitation on amount or type of damages, compensation or benefits payable by or for the Subcontractor, or any of its subcontractors, under applicable Worker's or Workmen's Compensation Acts, Disability Benefit Acts, Employee Benefit Acts nor by any requirement for insurance, or the furnishing of insurance by Subcontractor or any of its subcontractors, under this Subcontract. Subcontractor shall, however, maintain insurance with respect to this indemnification obligation and shall, in addition, name Manhattan as an additional insured which coverage for Manhattan, as an additional insured, shall not be affected by the enforceability or applicability of the above-referenced indemnity obligation.

2.5.4 The indemnity obligations shall survive completion or termination of the Subcontract.

2.5.5 Indemnitees shall have the right to select counsel of their own choosing to defend them and such selection shall not lessen or otherwise limit Subcontractor's obligations hereunder.

2.5.6 Nothing contained herein shall limit any claim of Manhattan against Subcontractor based on breach of contract or breach of warranty.

2.5.7 The above-referenced defense and indemnification obligations shall not require Subcontractor to defend and indemnify Architect or other design professionals (or their representatives, employees, agents, invitees and licensees) against claims arising out of the preparation or approval of maps, drawings, opinions, reports, surveys, change orders, designs or specifications, unless required by the agreement between Owner and Manhattan.

2.6 PATENTS AND ROYALTIES

Except as otherwise provided by the Contract Documents, Subcontractor shall pay all royalties and license fees which may be due with respect to the Work. Subcontractor shall defend all suits or claims for infringement of any patent rights that may be brought against Manhattan or Owner arising out of its Work, and shall be liable to Manhattan and Owner for all loss, including all costs and expenses, on account thereof.

2.7 TAXES AND PERMITS

2.7.1 Except as otherwise provided by the Contract Documents, Subcontractor agrees to pay, comply with and hold Manhattan harmless from and against the payment of all Federal, state and local contributions, taxes, duties or premiums arising out of the performance of this Subcontract, and all Sales, Use or other duties or taxes of whatever nature levied or assessed against Owner, Manhattan or Subcontractor arising out of this Subcontract, including any interest or penalties. Subcontractor waives any and all claims for additional compensation because of any new contributions, duties, taxes or premiums, or any increases therein, unless payment therefor is specifically provided for in the Contract Documents.

2.7.2 Subcontractor shall obtain and pay for all permits, licenses, fees and certificates of inspection necessary for the prosecution and completion of the Work. Subcontractor shall arrange for all necessary inspections and approvals by public officials.

2.8 SUPERVISION

Subcontractor and its subcontractors (a) shall not employ anyone to perform Work whose employment is objected to by Manhattan or Owner and (b) shall employ skilled and competent supervisory and subordinate personnel at the jobsite at all times who are familiar with their obligations under this Subcontract, the Contract Documents and Manhattan's schedule, are capable of communicating effectively with Manhattan's Project staff and who shall perform the Work with the highest degree of skill.

2.9 CLEANUP

Subcontractor shall, on a daily basis, clean its Work and remove, sort as required, and deposit all debris resulting from or associated with its Work in a manner that will not impede either the progress of the Project or of other trades. Should Subcontractor fail to clean

its Work within twenty-four (24) hours after receipt of written notice from Manhattan, Manhattan shall have the right to perform cleanup itself and charge Subcontractor the reasonable cost thereof, including an allocation of the cost of cleanup not identifiable to any source. Manhattan may request composite crew clean up activities in which this Subcontractor will participate, if performing Work during the period of such request.

2.10 LABOR HARMONY

Neither Subcontractor nor any of its subcontractors will directly or indirectly cause, or induce others to cause, any interference with the work of any other contractor or subcontractor. Subcontractor shall only employ workmen who will work in harmony with those employed by Manhattan and other subcontractors. Should any workers performing work covered by this Subcontract engage in a strike, work stoppage, work slowdown or cease to work due to picketing, protests, strikes or a labor dispute of any kind, said circumstance shall be deemed a failure to perform the work and shall constitute a default by Subcontractor, subjecting it to the terms and conditions set forth in Article 9 herein. Furthermore, Subcontractor acknowledges that the project will be constructed, and work performed, utilizing many other employers, subcontractors, suppliers, and vendors providing supplies and materials, who may or may not be a party to, or signatory to, collective bargaining agreements or project labor agreements. If pickets, protests, strikes or other forms of labor disputes occur at the jobsite, Subcontractor agrees that its employees and those of its subcontractors will either cross picket lines or enter the jobsite through a separate entrance established for such use. Failure of Subcontractor to man the job with a sufficient number of skilled workers during a labor dispute shall have no effect on Manhattan's remedies under Article 9 of this Subcontract. Subcontractor agrees that Manhattan is entitled to all remedies provided in Article 2.2, 2.4, and 9.1 of this Subcontract should Subcontractor delay the project as a result of a labor dispute of any nature. Prior to the commencement of its Work, Subcontractor shall inform Manhattan if any of the employees that it, or its subcontractors, intends to employ on the Project are subject to a collective bargaining agreement and whether or not any such agreement contains a valid no strike clause.

2.11 ASSIGNMENT AND SUBCONTRACTING

2.11.1 Subcontractor shall not assign or transfer this Subcontract, or funds due hereunder, without the prior written consent of Subcontractor's surety and Manhattan. To the extent any applicable law does not require Subcontractor to obtain written consent of Manhattan to the assignment of funds, Subcontractor nevertheless agrees to notify Manhattan, in writing, prior to any such assignment. Failure of Subcontractor to notify Manhattan shall constitute a material breach of this Subcontract. Subcontractor's subcontractors are subject to the provisions of this Subcontract, and Subcontractor shall insert in Subcontractor's subcontracts all provisions required by the Contract Documents or necessary to enable Subcontractor to comply with the terms hereof. Subcontracting by Subcontractor shall not abrogate any obligation of Subcontractor under this Subcontract.

2.11.2 Subcontractor shall, within thirty (30) days after award of this Subcontract and monthly thereafter, provide a detailed, itemized list of materials and equipment to be provided under this Subcontract along with the ultimate supplier of each material item and equipment, the supplier's representative and phone number, and the current proposed delivery date of the material and equipment. Manhattan reserves the right to review and/or approve Subcontractor's subcontractor. Such approval will not be unreasonably withheld.

2.11.3 Subcontractor, by execution of this Subcontract, contingently assigns to Manhattan all of Subcontractor's subcontracts. The assignment of each of Subcontractor's subcontracts shall take effect only upon both Subcontractor's termination under either Article 9 or 10 and Manhattan's affirmative acceptance of the assignment of the specific subcontract by written notice to Subcontractor and Subcontractor's subcontractor. Manhattan shall have no liability to any of Subcontractor's subcontractors unless and until Manhattan affirmatively accepts the assignment as provided above.

2.11.4 Subcontractor further agrees, if requested by Manhattan, to conditionally assign this Subcontract to Owner or Owner's lender.

2.12 APPROVALS, REVIEWS AND SUBSTITUTIONS

2.12.1 Subcontractor warrants and agrees that all requisite approvals from Owner as to its eligibility to serve as a subcontractor, and that reviews or approvals of all materials and performance of the Work as required by the Contract documents, are obtainable.

2.12.2 Subcontractor shall deliver to Manhattan copies (or electronic files in the format needed) of shop drawings, cuts, samples, material lists, and other submissions, including mock-ups and temporary structures, required by Manhattan or the Contract Documents within sufficient time so as not to delay performance of the Project and within sufficient time for Manhattan to submit the same within the time stated in the Contract Documents, whichever is earlier. Review or approval of a submittal does not constitute specific written approval. No general approval granted by Manhattan or Owner shall relieve Subcontractor from complying with the Contract Documents. Submissions shall be in strict accordance with the Contract Documents provided, however, that if Subcontractor wishes to propose a deviation from the Contract Documents, such deviation shall be clearly identified on the submission and accompanied by a letter describing in detail such deviation and the effect, if any, on Subcontractor's Work and on the Work of Manhattan or any of its other subcontractors on the Project, and the impact on the time of performance. Requested deviations will be allowed only in

accordance with the Contract Documents and when specific separate written approval referencing the deviation is given to Subcontractor by both Manhattan and Owner or its representatives. In making or seeking to make any substitution, Subcontractor hereby agrees to pay or reimburse Manhattan for any increase whatsoever in the cost of the work undertaken by Manhattan or by any of its other subcontractors as a result of any substitution made upon initiation of Subcontractor. Subcontractor agrees and represents, at the time of entering this Subcontract, that no substitution was contemplated in arriving at the amount of the Subcontract.

2.12.3 Manhattan's review or approval of any shop drawings, cuts, samples, material lists and other submissions, including mock-ups or temporary structures, shall not to any extent, under any circumstances, (a) alter the requirements of the Contract Documents for quality, quantity, finish, dimension, design or configuration; (b) constitute acceptance by Manhattan of any method, material or equipment not ultimately acceptable to Owner; or (c) relieve Subcontractor from its responsibilities and requirements in the Subcontract or for errors of any sort therein or from the necessity of furnishing any Work required by the Contract Documents which may have been omitted therefrom.

2.13 INSPECTION AND ACCEPTANCE

2.13.1 Subcontractor shall provide appropriate facilities at all reasonable times for inspection, by Manhattan or Owner, of the Work and materials provided under this Subcontract, whether at the Project site or any place where such Work or materials may be in preparation, manufacture, storage or installation. Subcontractor shall promptly replace or correct any Work or materials which Manhattan or the Owner shall reject as failing to conform to the requirements of this Subcontract. If Subcontractor does not do so within the time required by the Contract Documents, or, in the absence thereof, within a reasonable time, Manhattan shall have the right to do so and Subcontractor shall be liable to Manhattan for the cost thereof. If, in the opinion of Manhattan, it is not expedient to correct or replace all or any part of rejected Work or materials, then Manhattan, at its option, may deduct from the payments due, or to become due, to Subcontractor such amount as in Manhattan's reasonable judgment will represent (a) the difference between the fair value of the rejected Work and materials and the value thereof if it complied with this Subcontract, or (b) the cost of correction, whichever Manhattan determines is more appropriate.

2.13.2 Notwithstanding the above, if rejection of work is by Owner, or by Manhattan at the request of Owner, Subcontractor's remedy for wrongful rejection of work pursuant to Paragraph 2.13.1 shall be limited to Manhattan's remedy under the Contract Documents. Manhattan shall be liable for any increased direct cost caused by its wrongful rejection of Work only if Owner was not involved in any such rejection.

2.13.3 The Work shall be accepted according to the terms of the Contract Documents. Unless otherwise agreed in writing, however, entrance, occupancy and/or use by Owner or Manhattan of any part of the Project, or any equipment installed on the Project, shall not constitute acceptance of the Work, shall not establish the commencement date of any warranty, or be construed as an achievement of substantial completion of the Work.

2.13.4 Any quality control, quality assurance or inspection (or the failure to perform quality control, quality assurance or inspection) by Manhattan which involves Subcontractor's Work shall not relieve Subcontractor from its obligations in this Subcontract nor limit any liability which Subcontractor may have to Manhattan.

2.14 HOISTING AND SPECIAL RIGGING

2.14.1 Subcontractor shall perform all hoisting, rigging, and final placement of material and/or equipment as required for the Work.

2.14.2 Subcontractor is responsible for any and all special rigging, flagmen, spotters or other assistance necessary in connection with hoisting, as well as personnel required for off loading materials.

ARTICLE 3 **CLAIMS AND DISPUTES**

3.1 DEFINITION

A claim is a demand or assertion by one of the parties seeking, as a matter of right, adjustment or interpretation of Subcontract terms or payment of money, extension of time, or other relief with respect to the terms of the Subcontract.

3.2 LIMITATION ON CLAIMS

3.2.1 Claims by Subcontractor for additional compensation or for a time extension shall be made no later than the earlier of (a) forty-eight (48) hours after Subcontractor first recognizes the condition giving rise to the claim or (b) within a reasonable time so as to allow Manhattan to comply with the Contract Documents for the assertion of any claim. Claims must be made by written notice to Manhattan containing a complete description of the claim and circumstances thereof.

3.2.2 To the extent and only to the extent that Manhattan is liable for any damages to Subcontractor, the following limitations will apply:

- (a) No indirect or consequential damages will be allowed;
- (b) No recovery shall be based on a comparison of planned expenditures to total actual expenditures or on estimated losses of labor efficiency, or on a comparison of planned man loading to actual man loading, or any other analysis that is used to show damages indirectly;
- (c) Damages are limited to extra costs specifically shown to have been directly caused by a proven wrong;
- (d) No damages will be allowed for job or home office overhead computed on any Eichleay formula calculation or otherwise; and,
- (e) No profit will be allowed on any damage or backcharge claim.

3.2.3 Notwithstanding the foregoing limitations in Paragraph 3.2.2, Subcontractor shall be entitled to recover damages for delay or disruption to the extent, and only to the extent, that Manhattan is entitled to recover such damages from Owner and actually recovers funds from Owner for Subcontractor's claims.

3.2.4 Subcontractor waives all claims against Manhattan for consequential, special and indirect damages arising out of or relating to this Subcontract. In addition, the following damages, whether consequential, incidental, special, direct or otherwise are also waived: claims by Subcontractor for loss of financing, business and reputation, loss of bonding capacity, loss of business opportunity and increased interest or losses from or for damages allegedly caused to Subcontractor on any other contract between Subcontractor and any other third party, including contracts with Manhattan on other projects.

3.3 CONTINUING CONTRACT PERFORMANCE

In the event of any dispute involving the Work, Subcontractor must proceed diligently with performance of its Work and must follow any decision by Manhattan with respect to the dispute until final resolution. If Subcontractor makes a claim as provided herein, Subcontractor must continue with its Work without interruption, deficiency or delay.

3.4 ACCEPTANCE OF FINAL PAYMENT

Acceptance of final payment for the Work by the Subcontractor constitutes a waiver of any claims except those claims identified as being unresolved by the Subcontractor in writing at the time of final payment.

3.5 SETTLEMENT OF DISPUTES

3.5.1 In case of any dispute between Manhattan and Subcontractor in any way relating to or arising from any act or omission of Owner, the Architect, or involving the Contract Documents, Subcontractor agrees to be bound to Manhattan to the same extent that Manhattan is bound to Owner by the terms of the Contract Documents, and by any and all preliminary and final decisions or determinations made thereunder by any party, board or court so authorized in the Contract Documents or by law, whether or not Subcontractor is a party to such proceedings. In case of such dispute, Subcontractor will comply with all provisions of the Contract Documents and allow a reasonable time for Manhattan to analyze and forward to Owner any required communications or documentation sufficiently in advance of any time limits set forth in the Contract Documents. Manhattan may, at its option, (a) present to Owner, in Manhattan's name, (b) authorize Subcontractor to present to Owner, in Manhattan's name, all of Subcontractor's claims and answer Owner's claims involving Subcontractor's Work or (c) file a third party or separate action against Owner with respect to any liability Manhattan may have to Subcontractor. Manhattan may further invoke on behalf of Subcontractor, or allow Subcontractor to invoke, those provisions in the Contract Documents for determining disputes. Nothing herein shall require Manhattan to exercise any of the above options or to forward any claim to Owner or certify a claim under a contract. If certification is required by Owner, and if Manhattan elects to certify Subcontractor's claim, Subcontractor shall also certify its claim to both Manhattan and Owner and shall defend and indemnify Manhattan for any liability Manhattan may have as a result of said certifications. If such dispute is prosecuted by Manhattan, Subcontractor at its own expense agrees to furnish all documents, statements, witnesses, and other information required by Manhattan and to pay or reimburse Manhattan for all costs incurred by Manhattan in connection with the dispute, including attorneys' fees. In the event Manhattan elects and Subcontractor accepts the option of presenting its claims to Owner, in Manhattan's name, Subcontractor shall not perform any act, or fail to perform any act, which results in any liability to Manhattan. Manhattan shall have the right to have its legal counsel associate with Subcontractor's counsel in the prosecution of any such claim at Manhattan's expense.

3.5.2 All disputes between the parties shall be resolved by litigation, in a court of competent jurisdiction, except that Manhattan may, at its sole option, require that any dispute be submitted to arbitration pursuant to the Construction Industry Rules of the American Arbitration Association except that for disputes equal or less than \$500,000, a single arbitrator shall be appointed who will be an attorney with at least (10) years of experience in construction law, and for disputes involving \$500,000 or more, there shall be three (3) arbitrators with each being an attorney and having at least ten (10) years of experience in construction law. Manhattan shall not be deemed to have waived any right it may have to arbitrate its dispute with Subcontractor by the filing of litigation against

Subcontractor and its surety. At Manhattan's request, Subcontractor agrees to join in any motion Manhattan may file seeking stay of any suit pending resolution of any arbitration between Subcontractor and Manhattan. In any arbitration between Subcontractor and Manhattan, pretrial discovery shall be allowed to the full extent as permitted by the local rules of civil procedure in the state in which the project is located.

3.5.3 If Manhattan elects to arbitrate any such dispute with Subcontractor, Subcontractor consents to the joint arbitration of any dispute it might have with Manhattan with the arbitration of any dispute Manhattan might have with any other subcontractor of Manhattan or with Owner or Architect, if Manhattan should so elect. If Manhattan should so elect to arbitrate any such dispute, and if the arbitration rules of any other arbitration Manhattan might have with any other subcontractor or with Owner or Architect are different than the arbitration rules above, the rules of arbitration, as set forth in this Subcontract, shall be modified to conform with the rules of such other arbitration proceeding.

3.5.4 In the event of litigation or arbitration of any dispute between Subcontractor and Manhattan, the prevailing party shall be awarded attorneys' fees, costs of court and such other damages as may be permitted by the Subcontract and applicable law. A party shall not be deemed to be a prevailing party for the recovery of attorneys' fees unless it has either (a) been awarded or obtained a judgment for a substantial amount of its claim or (b) successfully defended against the majority of a claim being asserted by the other party. Notwithstanding the foregoing, if a party, against whom a claim is being made, makes a written offer of compromise to the claiming party, and if the written offer is not accepted by the claiming party within ten (10) days after receipt, the offering party shall be deemed to be the prevailing party if the claiming party does not obtain a more favorable judgment or arbitration award than the written offer of compromise. The above-referenced provision with respect to the tendering of a settlement offer shall not be applicable to any offer of compromise made within fifteen (15) days of the initial arbitration hearing date or trial date, as may be applicable.

3.5.5 Subcontractor agrees that the limitations period for the filing of any litigation or arbitration by Subcontractor against Manhattan shall be two years and one day following the date of substantial completion of Subcontractor's work. In the event the above-referenced provision shall be held to be unenforceable, the limitations period for the filing of any litigation or arbitration against Manhattan shall be two years and one day following the accrual of any cause of action; provided further, however, that if the applicable law does not permit the shortening of the limitations period as provided above, this clause shall be modified so as to require Subcontractor to file any such litigation or arbitration within the minimum period of time as may be allowed by law.

3.5.6 IN THE EVENT OF ANY LITIGATION SOLELY BETWEEN MANHATTAN AND SUBCONTRACTOR, SUBCONTRACTOR AND MANHATTAN AGREE TO WAIVE TRIAL BY JURY TO THE EXTENT SUCH WAIVER IS ENFORCEABLE PURSUANT TO THE LAWS OF THE PLACE OF THE PROJECT.

ARTICLE 4 **CHANGES IN THE WORK**

4.1 Manhattan may, at any time, unilaterally or by agreement with Subcontractor, without notice to any surety, make changes in the Work covered by this Subcontract. Any unilateral order or agreement under this Article 4 shall be in writing. Subcontractor shall perform the Work as changed without delay.

4.2 Subcontractor shall submit to Manhattan any requests or claims for adjustment in the price, schedule or other provisions of the Subcontract for changes directed by Owner. Subcontractor shall only obtain an adjustment to its Subcontract amount to the extent that Manhattan is entitled to relief from Owner. Further, each Subcontract adjustment shall be equal only to Subcontractor's allocable share of any adjustment in Manhattan's contract with Owner. Subcontractor's allocable share shall be determined by Manhattan, after allowance of Manhattan's normal overhead and profit on any recovery and Manhattan's expense of recovery, by making a reasonable apportionment, if applicable, between Subcontractor, Manhattan and other subcontractors or persons with interests in the adjustment. This paragraph shall also cover other equitable adjustments or other relief allowed by the Contract Documents.

4.3 Payment on account of pending changes made by Owner shall be made only if and when Manhattan receives such payment from Owner for Subcontractor's changed Work. Each payment to Subcontractor on account of pending change orders shall be equal to Subcontractor's allocable share of Manhattan's payment from Owner for the pending change as determined by Manhattan. Amounts paid on account of pending changes are provisional and not an admission of liability and shall be repaid to Manhattan on demand whenever Manhattan determines there has been an overpayment.

4.4 For changes ordered by Manhattan independent of Owner or the Contract Documents, Subcontractor shall be entitled to an equitable adjustment in the Subcontract price except to the extent in conflict with other terms of this Subcontract. If Subcontractor considers any action or inaction by Manhattan other than a formal change order to be a change, it shall so notify Manhattan in writing, within forty-eight (48) hours of said action or inaction and seek a confirmation from Manhattan. Failure to comply with said confirmation procedure shall constitute a waiver of the right to compensation for the action or inaction. Change orders or charges of any kind, occurring between Manhattan and Subcontractor independent of Owner or the Contract Documents shall be performed and

paid for on the basis of direct cost only, without any jobsite or home office overhead, indirect expense or profit. The limitations in Paragraph 3.2 above shall apply to any such claim.

4.5 Subcontractor shall submit a reasonable price quotation for any additive or deductive change requested by Manhattan or Owner. Subcontractor's quotation shall be furnished to Manhattan by the earlier of (a) seven (7) days following Manhattan's request or (b) in sufficient time to allow Manhattan to comply with the applicable provisions of the Contract Documents with respect to changes in the work. If Subcontractor does not do so and Manhattan elects or is required to submit a price quotation to Owner which includes a proposed additive or deductive change to Subcontractor's Work, Subcontractor waives any right of recovery with respect to any such additive change and any right to challenge any deductive change except for any amount for which payment is made by Owner for Subcontractor's portion of a proposed additive change.

4.6 The payment of any incremental increase in the cost of bonds arising as a result of changes in the Work shall be the responsibility of Subcontractor and will be included as a part of Subcontractor's price for proposed changes.

ARTICLE 5 **PAYMENTS**

5.1 SCHEDULE OF VALUES

5.1.1 Before the first application for payment, Subcontractor shall (1) provide a list of all of its known subcontractors, vendors and suppliers who will be furnishing materials, equipment or performing labor on the Project and (2) submit an itemized schedule of values ("Schedule of Values"), for Manhattan's approval, allocated to the various portions of the Work prepared in such form and supported by such data to substantiate its accuracy as Manhattan may reasonably require and/or as required by the Contract Documents. Subcontractor shall update the list of all of its subcontractors, vendors and suppliers with each subsequent application submitted.

5.1.2 This schedule, unless objected to by Manhattan, Owner or the Architect, will be used only as a basis of Subcontractor's applications for payment. The form of the application for payment will be as directed by Manhattan and/or as required by the Contract Documents together with applicable bills and payroll sheets.

5.2 APPLICATIONS FOR PAYMENT

5.2.1 Subcontractor must submit to Manhattan an itemized application for payment, notarized, if required by applicable law or requested by Owner, supported by such data substantiating the Subcontractor's right to payment as Manhattan, Owner or the Architect may require, including requisitions from subcontractors.

5.2.2 Subcontractor shall, as part of each request for partial payment, furnish conditional releases and lien waivers with respect to all Work performed and materials supplied in the current request for partial payment and, to the extent Subcontractor has received payment for previous pay applications, Subcontractor shall furnish a final lien waiver with respect to all Work performed and materials supplied to the extent Subcontractor has received payment. Subcontractor shall also furnish such documents as may be required by the Contract Documents and as allowed by law. Unless prohibited by law, and prior to final payment, Subcontractor shall provide to Manhattan a release of its liens and claims and satisfactory evidence that there are no other liens or claims whatsoever outstanding against the Work relating to this Subcontract and such other documents as may be required by the Contract Documents. To the extent applicable state law does not allow Manhattan to require an unconditional lien and claim release prior to final payment, Subcontractor shall provide a conditional release of its liens and claims and furnish a final unconditional lien and claim release once payment is received. Subcontractor shall insure that its subcontractors furnish all lien and claim releases which are required of Subcontractor.

5.2.3 If the Contract Documents allow partial payment for materials stored either off-site or on-site, such payments shall be made to Subcontractor in the amounts and under the standards set forth in the Contract Documents for off-site or on-site stored materials once such payments have been approved by Manhattan and Owner, but only after Manhattan's receipt of payment therefore from Owner.

5.2.4 No partial payment shall be due Subcontractor unless and until Manhattan receives payment from Owner and provided that the Work has been approved by Manhattan and Owner and provided that Subcontractor is in compliance with the terms of its Subcontract. Final payment shall not be due until Subcontractor's Work has been completed and approved by Owner, the entire Project is complete, all final payment prerequisites under the Contract Documents have been satisfied, satisfactory proof of payment of all amounts owed by Subcontractor in connection with this Subcontract has been provided and Manhattan has been paid in full for the entire Project. Notwithstanding the above, Manhattan may withhold from any partial or final payment to Subcontractor such amounts as may be allowed by the Subcontract in Paragraph 5.3. No certification of a progress payment and no partial or final payment made to Subcontractor pursuant to this Subcontract shall constitute or imply acceptance of Work or materials or any waiver

of any claim Manhattan may presently have or may in the future have against Subcontractor based on its duties and obligations under this Subcontract including, but not limited to, claims based on the failure of Subcontractor to have performed its Work in a good and workmanlike manner and in accordance with the Contract Documents.

5.2.5 If at any time any monies earned by or due to Manhattan from Owner are not paid in full, Manhattan shall in its sole discretion apportion the nonpayment equitably and reduce payments otherwise due Subcontractor accordingly. Such reductions shall continue until Manhattan is paid all monies due to it provided, however, if the withholdings do not relate to Subcontractor's Work, and if the reasons for non-payment are due to Manhattan's failure to meet its contractual obligations to Owner, Subcontractor shall be paid in full when Manhattan's right to recover from Owner is finally determined or expires. Subcontractor acknowledges that this paragraph establishes a reasonable time for payment.

5.2.6 Subcontractor shall pay all of its subcontractors all sums properly due its subcontractors for their work on the Project. Manhattan, after giving notice to Subcontractor, may pay all subcontractors which have not been paid the monies due them in connection with the Subcontract, whether or not a lien has been filed, unless Subcontractor, within three days of receipt of said notice, or such shorter period of time as Manhattan finds necessary to meet its obligations to Owner (a) demonstrates that such sums are not due and (b) provides Manhattan adequate security. Manhattan, without prejudice to any other right it may have, may issue a check to any subcontractor of Subcontractor, or may issue a joint check to Subcontractor and its subcontractor, and delivery of said check to either subcontractor or Subcontractor shall constitute payment to Subcontractor. Nothing contained herein shall create any duty on the part of Manhattan to make any payment to any such subcontractor of Subcontractor nor shall any contractual relationship be created by such payment.

5.2.7 Subcontractor agrees that Manhattan may, at any time, contact any of its subcontractors to verify amounts paid, amounts invoiced, scheduled time for performance and/or delivery of materials or for any other purpose reasonably related to the performance of the work of any such subcontractor on or for the Project and/or Subcontractor.

5.2.8 All material and Work incorporated into the Project or for which partial payment has been made shall become the property of Manhattan, or if the Contract Documents so provide, the property of Owner; however, this provision shall not relieve Subcontractor from the sole responsibility and liability for all Work and materials for which payments have been made until final acceptance thereof by Owner.

5.3 PAYMENTS WITHHELD

5.3.1 Notwithstanding any provision of the Subcontract to the contrary, Manhattan is not obligated to make any payment to Subcontractor under the Subcontract if any one or more of the following conditions exists:

- (a) Subcontractor has failed to perform its obligations under the Subcontract or otherwise is in default under the Subcontract or the Contract Documents;
- (b) If any part of such payment is attributable to Work which is not performed in accordance with the Contract Documents; provided, however, payment will be made for the portions of the Work which have been performed in accordance with the Contract Documents;
- (c) Subcontractor or any subcontractor has failed to make payments promptly to any of their subcontractors, as applicable, or to pay for material or labor used in the Work for which Subcontractor has received payment;
- (d) Subcontractor has failed to provide the revised Schedule of Values with the Application for Payment;
- (e) Reasonable evidence that the Work of Subcontractor cannot be completed for the unpaid balance of the Subcontract amount;
- (f) Reasonable evidence that the Work of the Subcontractor will not be completed within its scheduled time for completion and that the unpaid balance would not be adequate to cover any actual or liquidated damages for the anticipated delay;
- (g) Subcontractor has suspended the Work other than as authorized by Owner or the Contract; or
- (h) Subcontractor has filed a voluntary petition for protection or relief under applicable Bankruptcy laws of the United States or a petition has been filed placing Subcontractor under the protection of the Bankruptcy laws of the United States and Subcontractor has not (1) notified Manhattan that Subcontractor has the necessary capacity and resources to finish the Work and honor the Subcontract and will dismiss such petition and removed itself from bankruptcy protection within 90 days of the filing or (2) affirmed and had the bankruptcy

court approve its obligations under this Subcontract to Manhattan and evidence Subcontractor's ability to perform this Subcontract to Manhattan's reasonable satisfaction; or

- (i) Subcontractor has failed to provide or maintain required insurance or bonds.

5.3.2 In the event any of the conditions as outlined in Paragraph 5.3.1 exists, Manhattan may withhold such funds as may be reasonably necessary to protect it from liability or compensate it for its damages; provided, however, that the exercising of the right of withholding by Manhattan shall not be conclusive with respect to any liability of Subcontractor to Manhattan.

5.3.3 Manhattan may withhold funds from Subcontractor in an amount which represents Manhattan's good faith estimate of the attorneys' fees Manhattan may incur in any pending or threatened claim or dispute with Subcontractor.

5.4 **CONDITION PRECEDENT**

SUBCONTRACTOR EXPRESSLY ASSUMES THE RISK OF NON-PAYMENT BY OWNER. SUBCONTRACTOR AGREES THAT RECEIPT OF PAYMENT BY MANHATTAN FROM OWNER SHALL BE AN EXPRESS CONDITION PRECEDENT TO ANY PAYMENT OBLIGATION OF MANHATTAN OR ITS SURETY TO SUBCONTRACTOR.

NOTWITHSTANDING THE ABOVE, MANHATTAN SHALL NOT URGE THIS DEFENSE TO ANY PAYMENT OBLIGATION TO SUBCONTRACTOR IN THE EVENT THE FAILURE OF MANHATTAN TO RECEIVE PAYMENT FROM OWNER IS DUE TO MANHATTAN'S FAILURE TO MEET ITS CONTRACTUAL OBLIGATIONS TO OWNER AND WHICH FAILURE IS NOT THE RESULT OF SUBCONTRACTOR'S FAILURE TO MEET ITS CONTRACTUAL REQUIREMENTS.

THE ABOVE-REFERENCED CONDITION PRECEDENT SHALL APPLY TO ALL REQUESTS FOR PAYMENT BY SUBCONTRACTOR FOR PARTIAL PAYMENT, FINAL PAYMENT, EXTRA WORK, CLAIMS OR OTHERWISE. THE ABOVE-REFERENCED CONDITION PRECEDENT SHALL NOT BE USED AS A BASIS FOR INVALIDATION OF THE ENFORCEABILITY OR PERFECTION OF A MECHANIC'S LIEN BUT SHALL BE APPLICABLE TO ANY CLAIM AGAINST MANHATTAN OR MANHATTAN'S SURETY.

IN THE EVENT ANY OF THE PROVISIONS IN THIS SUBCONTRACT, WHICH CONDITION PAYMENT TO SUBCONTRACTOR BASED ON RECEIPT OF PAYMENT BY MANHATTAN FROM OWNER, ARE DETERMINED TO BE VOID OR UNENFORCEABLE, SUBCONTRACTOR AGREES THAT MANHATTAN SHALL NOT BE LIABLE FOR PRICE ESCALATIONS (PARAGRAPH 2.1.2) OR DISRUPTION DAMAGE (AS DEFINED IN PARAGRAPH 2.2.5) EXCEPT FOR ACTIVE INTERFERENCE AND MANHATTAN'S LIABILITY SHALL BE SUBJECT TO THE LIMITATIONS IN PARAGRAPH 3.2.2.

ARTICLE 6 **PROTECTION OF PERSONS AND PROPERTY**

6.1 Subcontractor must take all reasonable precautions for the safety of, and must provide all reasonable protection to prevent damage, injury or loss to:

- (a) all employees at the Project Site or engaged in the Work and all other persons who may be affected by the Work or are in proximity to the Work;
- (b) the Work and all materials and equipment to be incorporated into the Work, whether in storage on or off the Project Site, under the care, custody or control of the Subcontractor or any of its subcontractors;
- (c) other property at the Project Site or adjacent thereto, including all existing improvements not part of the Work, trees, shrubs, lawns, walks, pavements, roadways, structures and utilities not designated for removal, relocation or replacement in the course of construction;
- (d) the work of Manhattan, Owner or other separate contractors; and
- (e) all tenants and visitors to the Project.

6.2 Subcontractor must give all notices and comply with all applicable laws, ordinances, rules, regulations and lawful orders of any public authority bearing on the safety of persons or property or their protection from damage, injury or loss.

6.3 In addition to safety requirements imposed by law, Subcontractor shall comply with all safety requirements and policies imposed by Manhattan or Owner and will conduct operations in a safe manner. Subcontractor shall designate an employee to be responsible for compliance with all federal, state, and local safety and health regulations and all safety policies and requirements imposed by Manhattan or Owner. Unless the Subcontractor designates otherwise, the responsible employee shall be the

Subcontractor's job site supervisor. Subcontractor shall be liable to Manhattan for any additional costs including fines, which Manhattan incurs as a result of Subcontractor's failure to operate safely. Manhattan may conduct safety inspections from time to time. Such inspections shall not relieve Subcontractor from its obligations to adhere to safety requirements nor shall such inspections create any liability to Manhattan.

6.4 Any incident arising out of Subcontractor's work shall be discussed at the next Contractor's Safety Committee meeting to determine if the accident was preventable and to determine the responsible party. If the incident involved lost time, significant loss or involved a significant risk of loss, an officer or owner of Subcontractor shall attend the meeting and explain, in person, the cause of the accident and the action Subcontractor shall take to prevent similar accidents in the future. In the event Subcontractor has repeated safety issues on the Project, Manhattan may, at its sole discretion, require Subcontractor to furnish a full-time safety engineer for the Project at no additional cost. This safety engineer shall be responsible for full and complete understanding of the safety laws, rules and regulations, applicable to Subcontractor's work on the Project.

6.5 Subcontractor shall comply with all hazardous material requirements imposed by Manhattan or Owner. Subcontractor agrees to provide to Manhattan a copy of its Hazardous Communication Program for the project. Subcontractor agrees that in performing its work, it will not create, use or dispose of any hazardous chemicals or substances in an unlawful or hazardous manner and shall be solely responsible for the lawful, proper and safe handling, storage and removal of all hazardous wastes, chemicals, and substances which are introduced to the project site, or removed from the project site, by Subcontractor's operations. The term "hazardous wastes, chemicals or substances" shall mean those materials and substances prohibited, proscribed, or the use of which is controlled by any agent of the federal government or the applicable state or local agency having jurisdiction of such matters. Subcontractor shall comply with all federal, state and local regulations dealing with the use, storage or disposal of all hazardous wastes, chemicals and substances. **SUBCONTRACTOR SHALL BE RESPONSIBLE FOR ANY AND ALL CLAIMS AND DAMAGES RESULTING FROM ITS USE, HANDLING, STORAGE, REMOVAL AND DISPOSAL OF SUCH HAZARDOUS WASTES, CHEMICALS OR SUBSTANCES FROM THE PROJECT, AND SHALL DEFEND AND HOLD MANHATTAN HARMLESS FROM ANY AND ALL LIABILITY ASSOCIATED WITH SUCH USE, HANDLING, STORAGE, REMOVAL AND DISPOSAL INCLUDING ALL ASSOCIATED ATTORNEY'S FEES AND COSTS AND COSTS OF ALL CLEANUP OPERATIONS WHEREVER AND WHENEVER REQUIRED BY ANY GOVERNMENTAL AUTHORITY OR BY MANHATTAN.**

6.6 Subcontractor and its subcontractors, and all employees, servants and agents of any of them, shall comply strictly with the applicable requirements of the Occupational Safety and Health Act (OSHA) of 1970, as amended, and all other applicable health and safety laws and regulations.

ARTICLE 7 **INSURANCE**

Insurance requirements are set forth in the insurance rider attached hereto titled Insurance Requirements of Subcontractor. Subcontractor also acknowledges that additional insurance requirements are set forth in other provisions of the Manhattan General Provisions.

ARTICLE 8 **PERFORMANCE BOND AND LABOR AND MATERIAL PAYMENT BOND**

8.1 If required by the Subcontract, Subcontractor must furnish to Manhattan and keep in force the required bonds, being both a performance bond (for the Work) and labor and material payment bond (covering the cost of the Work) guaranteeing that Subcontractor will perform its obligations under the Subcontract and will pay for all labor and materials furnished for the Work and will be responsible for damages resulting from any defective or non-conforming work (including the replacement thereof) performed by Subcontractor. Subcontractor's surety shall be liable to the same extent as Subcontractor is liable under the terms of this Subcontract which liability includes, but is not limited to, defects in Subcontractor's work which are discovered following the date of the completion of the work required by this Subcontract. Each bond must be issued in a form (refer to Exhibit "B") and by a surety acceptable to Manhattan, must be submitted to Manhattan for approval as to form, must name Manhattan as obligee and each must be in an amount equal to at least 100% of the Subcontract amount (as the same may be adjusted from time to time pursuant to the Contract), unless a greater amount is required by applicable law, in which case such greater amount will control. The Subcontractor must deliver the approved and executed bonds to Manhattan upon execution of this Subcontract. In the event the surety which provided bonding becomes insolvent or fails, Subcontractor shall immediately replace, at its expense, the bonds with valid bonds from a new surety meeting the above requirements. Failure of Subcontractor to replace bonds shall constitute a failure to comply with this Subcontract which, at Manhattan's election, shall allow withholding of funds, termination and other relief as set forth in Paragraph 5.3.1 and Article 9 herein.

8.2 The payment bond must be issued in a form consistent with and as may be required by all applicable laws for the state in which the Project is located, such that, to the fullest extent possible at law, no liens can attach to the Project and all mechanics or materialmen's liens filed in connection with the Work or the Project will attach only to the bonds.

8.3 Notwithstanding the above, and in the event that liens are filed by anyone in relation to the labor performed and/or material furnished pursuant to this Subcontract, Subcontractor agrees to have the same discharge by posting a bond with the appropriate authorities, or otherwise, within three days of notice. In the event such lien is not so discharged, Manhattan may discharge the lien itself and hold Subcontractor responsible for all costs and obligations incurred.

8.4 If Subcontractor is not required to furnish bonds, or if Manhattan desires Subcontractor to provide additional bond coverage, Manhattan may, at any time, and upon written request, instruct Subcontractor to provide, and Subcontractor shall so provide within ten (10) days, performance and payment bonds as provided in this Article 8. In this event, Manhattan will reimburse Subcontractor for reasonable bond premiums.

ARTICLE 9

SUBCONTRACTOR'S FAILURE TO PERFORM; TERMINATION FOR DEFAULT

9.1 If, in the opinion of Manhattan, Subcontractor shall at any time (a) refuse or fail to provide sufficient properly skilled workers, adequate supervision or materials of the proper quality, (b) fail in any material respect to prosecute the Work according to Manhattan's current schedule, (c) cause, by any action or omission, the stoppage or delay of or interference with the Work of Manhattan or of any other contractor or subcontractor, (d) fail to comply with any provision of this Subcontract or the Contract Documents, (e) make a general assignment for the benefit of its creditors, (f) have a receiver appointed, or (g) become insolvent, then, after serving forty-eight (48) hour written notice (unless a shorter period is required in the Subcontract or by the Contract Documents), unless the condition specified in such notice shall have been eliminated within such forty-eight (48) hours, Manhattan, at its option, without voiding the other provisions of this Subcontract and without notice to the sureties, and without prejudice to any other rights of Manhattan under the law, may (i) take such steps as are necessary to overcome or correct the condition (including supplementing the work of Subcontractor), in which case the Subcontractor shall be liable to Manhattan for the cost thereof (ii) terminate for default Subcontractor's performance of all or a part of the Subcontract Work, or (iii) obtain specific performance or interlocutory mandatory injunctive relief requiring performance of Subcontractor's obligations hereunder (it being agreed by Subcontractor that such relief may be necessary to avoid irreparable harm to Manhattan and/or the Owner).

9.2 In the event that Manhattan exercises its options under Paragraph 9.1 (i) or (ii), Manhattan may, at its option, (a) enter on the premises and take possession, for the purpose of completing the Work, of some or all of the materials and equipment of Subcontractor, (b) take assignment of any or all of Subcontractor's subcontracts, and/or (c) either itself or through others complete the Work by whatever method Manhattan may deem expedient. Subcontractor shall not be entitled to receive any further payment until the Work is fully completed and accepted by the Owner and payment is received from the Owner. At such time, if the unpaid balance of the price to be paid shall exceed the expense incurred by Manhattan, including overhead and profit, such excess shall be paid by Manhattan to Subcontractor. If such amount shall exceed such unpaid balance, the Subcontractor shall pay Manhattan the difference on demand.

9.3 If Manhattan wrongfully exercises its option under Paragraph 9.1(i) that action shall be treated as a deductive change. If Manhattan wrongfully exercises its option under Paragraph 9.1(ii), that termination for default shall be considered a termination for Manhattan's convenience and Subcontractor shall be entitled to the applicable compensation provided in Article 10. Subcontractor's remedies under this Paragraph 9.3 shall be exclusive. Nothing herein shall bar withholdings by Manhattan permitted by other provisions of this Subcontract.

ARTICLE 10

TERMINATION FOR CONVENIENCE

Manhattan shall have the right to terminate for convenience Subcontractor's performance of all or any part of the Work by providing Subcontractor with a written notice of termination for convenience, to be effective upon receipt by Subcontractor and regardless of whether Owner has terminated Manhattan's work. If there has been a termination of Manhattan's Contract with Owner, Subcontractor shall be paid the amount due from Owner for its Work, as provided in the Contract Documents, after payment therefor by Owner to Manhattan. If Manhattan's Contract has not been terminated, Subcontractor shall be paid the reasonable value of the Work performed by Subcontractor prior to termination plus reasonable direct close-out costs, including job site overhead and profit on Work performed, but in no event shall Subcontractor be entitled to unabsorbed overhead, anticipatory profit or damages of any kind or nature, direct or indirect, incidental or consequential. If no work has been performed by Subcontractor at the time of termination, Subcontractor shall be paid the sum of \$10.00 for its undertaking an obligation to perform.

ARTICLE 11
LAWS, REGULATIONS AND ORDINANCES

11.1 Subcontractor shall be bound by, and at its own cost shall comply with, all Federal, state and local laws, codes, ordinances and regulations applicable to this Subcontract and the performance of the Work whether by reason of general law or by reason of provisions in the Contract Documents. Subcontractor and all of its subcontractors shall be duly licensed to operate under the laws of all applicable jurisdictions.

11.2 Subcontractor shall be liable to Manhattan and Owner for all loss, damage, cost and expense attributable to any acts of commission or omission by Subcontractor, or any of its subcontractors, and all employees, servants or agents of any of them, resulting from failure to comply with any Federal, state or local laws, codes, ordinances or regulations including, but not limited to, any fines, penalties or corrective measures.

ARTICLE 12
EQUAL OPPORTUNITY

12.1 In connection with the performance of the work, Subcontractor agrees to support Equal Employment Opportunity for all persons, regardless of race, color, religion, sex, national origin, marital status, physical disability, medical condition, age, genetic information, status as a Disabled Veteran, Recently Separated Veteran, Other Protected Veteran and Armed Forces Service Medal Veteran with respect to recruitment, hiring, training, promotion, and other terms and conditions of employment, provided the individual is qualified to perform the work available. Further, Subcontractor shall comply with the concepts and practices of affirmative action. Accordingly, all employment decisions shall be consistent with the principle of Equal Employment Opportunity (EEO). All promotion decisions shall be consistent with the principle of EEO and only valid qualifications will be required for promotion. All other personnel actions or programs such as compensation, benefits, transfers, layoffs, recalls, company sponsored training, social and recreational programs will be administered in a non-discriminatory manner with respect to minorities and women, provided the individual is qualified to perform the work available.

12.2 Subcontractor agrees to post in conspicuous places, available for employees and applicants for employment, notices prepared by Subcontractor and approved by the Government, when required, setting forth the provisions of this Paragraph. Subcontractor shall permit access to its books, records and accounts by representatives of Manhattan or Owner for purposes of investigation to ascertain compliance with the provisions of this Paragraph.

12.3 Subcontractor shall include the provisions of this Paragraph in Subcontractor's subcontracts. The requirements of this Article 12 shall be in addition to any Equal Opportunity provisions of the Contract Documents and other laws, regulations and ordinances as set forth in Article 11 above.

ARTICLE 13
ADDITIONAL TERMS AND CONDITIONS

13.1 LAYOUT AND ENGINEERING

Manhattan shall furnish bench marks and base control lines for use by all of its subcontractors. All other layout, field engineering and field measurements required for the execution of this Subcontract shall be provided by Subcontractor.

13.2 USE OF TEMPORARY FACILITIES

Subcontractor, except for on-site offices and fabrication plants, may share with Manhattan and its other subcontractors, at no charge, electrical power, OSHA standard lighting, water, and sanitation services which Manhattan has available. Any additional services, including lighting, additional outlets, and/or water requirements, which Subcontractor may require for the performance of its Work or the protection of its Work, materials, and equipment from the elements and against theft and vandalism shall be Subcontractor's responsibility.

13.3 INTERFACE AND COORDINATION

13.3.1 Subcontractor, as well as its subcontractors and employees, shall cooperate and fully coordinate their Work with one another and all of Manhattan's other subcontractors for the purpose of securing a complete project as required by the Project schedule.

13.3.2 Subcontractor shall review the critical dimensions and elevations of its Work, and verify the previous Work as to its relationship to the Subcontractor's Work. The Subcontractor shall promptly submit a written statement to Manhattan noting any discrepancies or unacceptable conditions prior to commencing with the Work of this Subcontract. Subcontractor shall not attach to or cover over any material which is not properly installed. Failure by Subcontractor to notify Manhattan of unacceptable discrepancies or unacceptable conditions of previous work shall constitute a waiver of any claims by Subcontractor and it shall be deemed that Subcontractor has accepted the conditions of all previous work.

13.4 PROTECTION OF MATERIALS/TOOLS/EQUIPMENT

Subcontractor shall secure and adequately protect, all materials, tools, and equipment delivered for or incorporated in the Work until the time of final acceptance by the Owner. This shall include protection from the weather and all other elements of nature, as well as any damage which may be done to same due to vandalism, theft, or any cause.

13.5 TESTS AND INSPECTIONS

All costs associated with the failure of, or unpreparedness for, any required testing and/or inspection relating to the Work shall be the responsibility of Subcontractor.

13.6 CONSTRUCTION REPORTS

Subcontractor is required to submit a Daily Construction Report to Manhattan. The Report must include a description of the Subcontractor's activities for the day, a work force count by trade for both the Subcontractor and its subcontractors, as well as a listing of any major deliveries, worker injuries or job delays and impacts. The Reports must be submitted by noon the following day. Subcontractor shall provide safety data including the entries from the OSHA 300 Report and man hours worked on a quarterly basis or more often as required. Names or sensitive information can be omitted since the intent of the above-referenced requirements is to achieve better overall job safety.

13.7 RECORD DOCUMENTS

Subcontractor shall daily maintain an up-to-date and accurate record of all deviations from the approved drawings, specifications, and shop drawings which may occur in the Work as actually constructed, and shall submit to Manhattan for submission to the Owner, at completion of the Work prior to final payment and at other times as reasonably requested by Manhattan, including as part of the Application for Payment process, completely corrected record drawings and specifications (including documents electronically created or maintained) representing the actual condition of the Work.

13.8 ELECTRONIC SOFTWARE

Subcontractor shall furnish and maintain all required electronic software to perform its Work including any software which may be necessary so as to guarantee that Subcontractor's work will be compatible with the work of other subcontractors to Manhattan, Manhattan, the Architect and its consultants and any Owner requirements.

13.9 DRUG-FREE AND TOBACCO-FREE WORKPLACE PROGRAM

Subcontractor shall adopt Manhattan's Drug-Free and Tobacco-Free Workplace Program, or a substantially similar policy, for its own employees, agent and representatives who come onto the jobsite and shall require its subcontractors who come onto the jobsite to do likewise. If Subcontractor, or anyone who comes onto the jobsite under an employment or other contractual arrangement with Subcontractor, whether direct or indirect, fails to enforce Manhattan's Drug-Free and Tobacco-Free Workplace Program, or such substantially similar policy, Manhattan reserves the right to bar such party from the jobsite. Any resulting damage (including damage for delay) will be the responsibility of Subcontractor. Copies of Manhattan's Drug-Free and Tobacco-Free Workplace Program will be made available to Subcontractor upon request.

13.10 ADVERTISING - SIGNS

Neither Subcontractor, or its subcontractors, or any of their employees shall take photographs of the Work or site, publish or display advertising matter of any description relating to the Project, or display signs at or near the Project without first obtaining the written consent of Manhattan and Owner.

ARTICLE 14
MISCELLANEOUS

14.1 NOTICES

All notices shall be addressed to the parties at the addresses set out herein, and shall be considered as delivered on the earlier of (a) when signed for or (b) three working days after postmarked, if the notice is dispatched by registered or certified mail, when confirmed if sent by electronic mail, telegram or telecopy, when signed for when delivered by hand, and when received in all other cases. If notice is made by one or more of the methods above, the delivery date of the notice shall be deemed to be the earliest of the delivery dates referenced above. Unless otherwise provided in the Subcontract, all notices from Subcontractor to Manhattan shall be to the attention of Manhattan's Project Manager.

14.2 SEVERABILITY AND WAIVER

The partial or complete invalidity of any one or more provisions of this Subcontract shall not affect the validity or continuing force and effect of any other provision. If any provision is invalid, in whole or in part, the provision shall be considered reformed to reflect the intent thereof to the greatest extent possible consistent with law. The failure of either party to insist, in any one or more instances, upon the performance of any of the terms, covenants, or conditions of this Subcontract, or to exercise any right herein, shall not be construed as a waiver or relinquishment of such term, covenant, condition or right as respects to further performance.

14.3 INDEPENDENT CONTRACTOR

Subcontractor acknowledges and agrees that it is being retained as an independent contractor.

14.4 EXECUTION OF ADDITIONAL DOCUMENTS

Subcontractor agrees to execute such additional documents as may be reasonably required by any lender to Owner, such as a subordination agreement with respect to any lien rights of Subcontractor, a waiver of rights to removables (to the extent such right is allowed by law), and a consent to continue work for a lender and/or its designee in the event of a default by the Owner.

14.5 ACKNOWLEDGMENT OF RECEIPT

Subcontractor acknowledges that it has received and reviewed the foregoing Manhattan General Provisions. Subcontractor agrees that the terms of these General Provisions will be incorporated into, as if fully written out, any Subcontract Manhattan, or any of its affiliates, and Subcontractor, or any company affiliated with Subcontractor, execute in the future provided that these Manhattan General Provisions are referenced in any such future Subcontract. The execution of this acknowledgment and receipt shall not confer any rights to Subcontractor unless and until a Subcontract is executed between the parties incorporating these provisions.

14.6 DEFENSES OF MANHATTAN'S SURETY

Notwithstanding any statute or other law or rule to the contrary, Manhattan's surety (or sureties) may rely on all of Manhattan's defenses to Subcontractor's claims as may be allowed under the terms of this Subcontract and applicable law, including, but not limited to, the failure of satisfaction of conditions precedent to Manhattan's obligation to pay Subcontractor as set forth in Paragraph 5.4 of Manhattan's General Provisions, any exclusions or limitations on Subcontractor's recovery for delays, inefficiencies or lost productivity and Subcontractor's waiver of consequential damages.

14.7 OTHER PROVISIONS

Those other documents forming part of the Manhattan General Provisions and the Contract Documents, and incorporated herein by reference, are as follows:

- Insurance Requirements of Subcontractor Rider (Five Pages)
- Louisiana Rider (One Page)
- Oklahoma Rider (One Page)
-
-

Subcontractor ABC
SUBCONTRACTOR

Manhattan Construction Company
MANHATTAN

Signature: _____

Signature: _____

Title:

Title: Senior Vice President

Printed Name:

Printed Name:

Date:

Date:

Insurance Requirements of Subcontractor

1. Specific Insurance Requirements

The following insurance shall be maintained in effect with limits not less than those set forth below at all times during the term of each Subcontract and thereafter as required:

Insurance	Coverage/Limits	Other Requirements
Commercial General Liability (Occurrence Basis)	<ul style="list-style-type: none"> • \$1,000,000 Per Occurrence • \$2,000,000 General Aggregate • \$2,000,000 Products/Completed Operations Aggregate • \$1,000,000 Personal And Advertising Injury • Designated Construction Project(s) General Aggregate Limit 	<ul style="list-style-type: none"> • Current ISO edition of CG 00 01 • The personal injury contractual liability exclusion shall be deleted • Additional insured status shall be provided in favor of Contractor Parties on a combination of ISO forms CG 20 10 10 01 and CG 20 37 10 01 • This coverage shall be endorsed to provide primary and non-contributing liability coverage. It is the intent of the parties to this Agreement that all insurance coverage required herein shall be primary to and shall seek no contribution from all insurance available to Contractor Parties, with Contractor Parties' insurance being excess, secondary and non-contributing • This policy and all policies provided herein shall be endorsed to provide thirty (30) days prior written notice of cancellation of coverage to Manhattan • The following exclusions/limitations (or their equivalent(s), are prohibited: <ul style="list-style-type: none"> ○ Contractual Liability Limitation CG 21 39 ○ Amendment of Insured Contract Definition CG 24 26 ○ Limitation of Coverage to Designated Premises or Project, CG 21 44 ○ Exclusion-Damage to Work Performed by Subcontractors On Your Behalf, CG 22 94 or CG 22 95 ○ Any Construction Defect Completed Operations exclusion ○ Any endorsement modifying or deleting the exception to the Employer's Liability exclusion ○ Any endorsement deleting or modifying coverage for explosion, collapse or underground work ○ Any "Insured vs. Insured" exclusion ○ Any Punitive, Exemplary or Multiplied Damages exclusion ○ Any Residential or Habitational exclusion if such work is to be performed ○ Any Subsidence exclusion
Business Auto Liability	\$1,000,000 Per Accident	<ul style="list-style-type: none"> • Current ISO edition of CA 00 01 • Arising out of any auto (Symbol 1), including owned, hired and nonowned
Workers' Compensation and Employer's Liability	<ul style="list-style-type: none"> • Statutory Limits • \$1,000,000 Each Accident and Disease • USL&H must be provided where such exposure exists. 	<ul style="list-style-type: none"> • The State where work is to be performed must be listed under Item 3.A. on the Information Page • Such insurance shall cover liability arising out of the Subcontractor's employment of workers and anyone for whom the Subcontractor may be liable for workers' compensation claims. Workers' compensation insurance is required, and no "alternative" forms of insurance shall be permitted • Where a Professional Employer Organization (PEO) or "leased employees" are utilized, Subcontractor shall require its leasing company to provide Workers' Compensation insurance for said workers and such policy shall be endorsed to provide an Alternate Employer endorsement in favor of Subcontractor. Where Subcontractor uses leased employees with Workers' Compensation insurance provided by a PEO or employee leasing company, Subcontractor is strictly prohibited from subletting any of its work without the express written agreement of Manhattan
Excess Liability (Occurrence Basis)	\$3,000,000 Each Occurrence	<ul style="list-style-type: none"> • Such insurance shall be excess over and be no less broad than all coverages described above • Drop-down coverage shall be provided for reduction and/or exhaustion of underlying aggregate limits and shall include a duty to defend any insured

Professional Liability (If Applicable)	<ul style="list-style-type: none"> • \$2,000,000 Each Occurrence • Such insurance shall cover all services rendered by the Subcontractor and its consultants under the Contract Documents, including but not limited to design or design/build services. • Policies written on a Claims-Made basis shall have an extended reporting period of at least two years beyond termination of each Subcontract. 	This insurance is not permitted to include any type of exclusion or limitation of coverage applicable to claims arising from: <ul style="list-style-type: none"> • bodily injury or property damage where coverage is provided on behalf of design professionals or design/build contractors • habitational or residential operations • mold and/or microbial matter and/or fungus and/or biological substance • punitive, exemplary or multiplied damages
Pollution Liability (If Applicable)	<ul style="list-style-type: none"> • \$2,000,000 Each Occurrence • Such insurance must provide third party liability coverage for bodily injury, property damage, clean up expenses, and defense arising from the operations. • All coverage provided in the policy shall apply to operations and completed operations of Subcontractor without separate restrictions for either of these time frames. • Mold and/or microbial matter and/or fungus and/or biological substance shall be specifically included within the definition of Pollutants in the policy. 	This insurance is not permitted to include any type of exclusion or limitation of coverage applicable to claims arising from: <ul style="list-style-type: none"> • asbestos or lead • contractual assumption of liability • impaired property that has not been physically injured • materials supplied or handled by the named insured. However, exclusions for the sale and manufacture of products are allowed. Exclusionary language pertaining to materials supplied by the insured shall be reviewed by the certificate holder for approval. • property damage to the work performed by the contractor • punitive, exemplary or multiplied damages • work performed by subcontractors

2. General Insurance Requirements

A. Definitions

- i. “Contractor Parties” means (a) Manhattan, (b) the Owner, (c) Architects/Engineers (regardless of whether Owner or Manhattan retains the Architects/Engineers), (d) the Project, (e) any lender whose loan is secured by a lien against the Work, (f) their respective shareholders, members, partners, joint venturers, affiliates, subsidiaries, successors and assigns, (g) any directors, officers, employees, or agents of such persons or entities, and (h) others as required by the Construction Documents.
- ii. “Subcontractor” shall include subcontractors of any tier.
- iii. “ISO” means Insurance Services Office.

B. Policies

- i. Subcontractor shall maintain such General Liability, Excess Liability, and if applicable Professional and Pollution Insurance in identical coverage, form and amount, including required endorsements, for the greatest of the following periods of time: (a) four (4) years following Date of Substantial Completion of the Work to be performed under the Subcontract (b) the expiration of any applicable statute of limitation or repose or (c) as may be required by the Contract Documents.
- ii. All policies must:
 - a. Be written through insurance companies authorized to do business in the State in which the work is to be performed and rated no less than A- VII in the most current edition of A. M. Best’s Key Rating Guide.
 - b. Provide a waiver of subrogation in favor of Contractor Parties on all insurance coverage carried by Subcontractor, whether required herein or not

- c. Be provided to the Contractor Parties in compliance with the requirements herein and shall contain no endorsements that restrict, limit, or exclude coverage required herein in any manner without the prior express written approval of Manhattan.
- iii. Failure of Manhattan to demand such certificate or other evidence of full compliance with these insurance requirements or failure of Manhattan to identify a deficiency from evidence that is provided shall not be construed as a waiver of the Subcontractor's obligation to maintain such insurance.
- iv. Subcontractor shall provide to Manhattan a certified copy of all insurance policies required herein within ten (10) days of any such request. Renewal policies, if necessary, shall be delivered to Manhattan prior to the expiration of the previous policy.
- v. Commencement of Work without provision of the required insurance and/or required endorsements, or without compliance with any other provision of the Contract Documents, shall not constitute a waiver by any Contractor Party of any rights. Manhattan shall have the right, but not the obligation, of prohibiting the Subcontractor or any sub-subcontractor from performing any Work until such certificates of insurance and/or required endorsements are received and approved by Manhattan.

C. Limits, Deductibles and Retentions

- i. The limits of liability may be provided by a single policy of insurance or by a combination of primary and excess policies, but in no event shall the total limits of liability available for any one occurrence or accident be less than the amount required herein.
- ii. No deductible or self-insured retention shall exceed \$25,000 without prior written approval of Manhattan. All deductibles and/or retentions shall be paid by, assumed by, for the account of, and at the Subcontractor's sole risk. The Subcontractor shall not be reimbursed for same.

D. Forms

- i. If the forms of policies, endorsements, certificates or evidence of insurance required by this Exhibit are superseded or discontinued, Manhattan will have the right to require other equivalent forms.
- ii. Any policy or endorsement form other than a form specified in this Rider must be approved in advance by Manhattan.

E. Evidence of Insurance Insurance must be evidenced as follows:

- i. ACORD Form 25 Certificate of Liability Insurance for liability coverages.
- ii. Evidence shall be provided to Manhattan prior to commencing Work and prior to the expiration of any required coverage.
- iii. ACORD Forms specify:
 - a. Manhattan as certificate holder at Manhattan's mailing address;
 - b. Insured's name, which must match that on the Subcontract;
 - c. Insurance companies producing each coverage and the policy number and policy date of each coverage;
 - d. Producer of the certificate with correct address and phone number and have the signature of the authorized representative of the producer;
 - e. Additional Insured status in favor of Contractor Parties;
 - f. Amount of any deductible or self-insured retention in excess of \$25,000;
 - g. Designated Construction Project(s) General Aggregate Limit;
 - h. Personal Injury Contractual Liability;
 - i. Primary and non-contributory status;
 - j. Waivers of subrogation; and
 - k. All exclusions and limitations added by endorsement to the General Liability coverage. This can be achieved by provision of the Schedule of Forms and Endorsements page.**
- iv. Copies of the additional insured endorsement(s) and the 30 Day Notice of Cancellation endorsement applicable to the General Liability policy shall also be provided.

F. Subcontractor Insurance Representations to Contractor Parties

- i. It is expressly understood and agreed that the insurance coverages required herein (a) represent Contractor Parties' minimum requirements and are not to be construed to void or limit the Subcontractor's indemnity obligations as contained in the Contract Documents nor represent in any manner a determination of the insurance coverages the Subcontractor should or should not maintain for its own protection; and (b) are being, or have been, obtained by the Subcontractor in support of the Subcontractor's liability and indemnity obligations under the Contract Documents. Irrespective of the requirements as to insurance to be carried as provided for herein, the insolvency, bankruptcy or failure of any insurance company carrying insurance of the Subcontractor, or the failure of any insurance company to pay claims accruing, shall not be held to affect, negate or waive any of the provisions of the Contract Documents.

- ii. Failure to obtain and maintain the required insurance shall constitute a material breach of, and default under, the Subcontract. If the Subcontractor shall fail to remedy such breach within five (5) business days after notice by Manhattan, the Subcontractor will be liable for any and all costs, liabilities, damages and penalties resulting to the Contractor Parties from such breach, unless a written waiver of the specific insurance requirement(s) is provided to the Subcontractor by Manhattan. In the event of any failure by the Subcontractor to comply with the provisions of the Contract Documents, Manhattan may, without in any way compromising or waiving any right or remedy at law or in equity, on notice to the Subcontractor, purchase such insurance, at the Subcontractor's expense, provided that Manhattan shall have no obligation to do so and if Manhattan shall do so, the Subcontractor shall not be relieved of or excused from the obligation to obtain and maintain such insurance amounts and coverages.
- iii. This Rider is an independent contract provision and shall survive the termination or expiration of any individual Subcontract.

G. Equipment Insurance: Subcontractor's Responsibility for Loss and Damage

- i. Subcontractor shall furnish equipment insurance which shall protect Subcontractor against losses caused by physical damage or theft to any of Subcontractor's tools, equipment and materials which are used to perform the Work but which are not actually incorporated into the Work if such coverage is so desired by Subcontractor. Subcontractor and its Insurance Carrier waive all rights of subrogation in favor of the Contractor Parties.
- ii. Subcontractor is fully responsible for loss and damage to its property on the site, including tools and equipment, and shall take necessary precautions to prevent vandalism, theft, burglary, pilferage and unexplained disappearance of property. Any insurance covering Subcontractor's or its subcontractor's property shall be Subcontractor's and its subcontractor's sole and complete means or recovery for any such loss. To the extent any loss is not covered by said insurance or subject to any deductible or co-insurance, Subcontractor shall not be reimbursed for same. Should Subcontractor or its subcontractors fail to insure this risk, it is expressly agreed that Subcontractor hereby waives, and shall cause its subcontractors to waive, any claim for damage or loss to said property in favor of Contractor Parties.

H. Insurance Required of Subcontractor's subcontractors

Insurance similar to that required of Subcontractor shall be provided by all of Subcontractor's subcontractors (or provided by Subcontractor on behalf of its subcontractors) to cover operations performed under any subcontract agreement. Subcontractor shall be held responsible for any modification in these insurance requirements as they apply to its subcontractors. SUBCONTRACTOR AGREES TO INDEMNIFY, DEFEND AND HOLD CONTRACTOR PARTIES' HARMLESS FOR ANY FAILURE OF SUBCONTRACTOR OR ANY OF ITS SUBCONTRACTORS TO OBTAIN AND MAINTAIN THE REQUIRED INSURANCE COVERAGES. Subcontractor shall maintain certificates of insurance from all of its subcontractors containing provisions similar to those listed herein (modified to recognize that the certificate is from its subcontractor) enumerating, among other things, the waivers of subrogation, additional insured status, and primary liability as required herein, and make them available to Manhattan upon request.

I. Builder's Risk

Owner or Manhattan shall obtain builder's risk insurance for the Work, insuring against all risks of direct physical loss or damage to materials, equipment, machinery and other property incorporated in the job, subject to policy exclusions and deductibles. The builder's risk policy shall be made available for inspection by Subcontractor prior to the execution of each Subcontract. It shall be the duty of Subcontractor to fully investigate all coverage provisions of the builder's risk insurance, including exclusions. By executing each Subcontract, Subcontractor shall be deemed to have accepted all the terms, coverages and exclusions of the builder's risk policy. The builder's risk policy shall not provide coverage for materials, tools, equipment, machinery or other items which Subcontractor uses in connection with the Work and which are not incorporated into or intended to become a permanent part of the Work. Subcontractor waives all right of subrogation against Owner, Manhattan, and the other Subcontractors for damage and loss caused by fire or other perils, to the extent covered by property insurance obtained pursuant to this provision or other property insurance applicable to the Work. A waiver of subrogation shall be effective as to a person or entity even though that person or entity would otherwise have a duty of indemnification, contractual or otherwise, did not pay the insurance premium directly or indirectly, and whether or not the person or entity had an insurable interest in the property damaged. If Subcontractor makes a claim on the builder's risk policy, or a claim is submitted on its behalf, Subcontractor shall pay its pro rata share of the policy's deductible amount, up to and including 100% if applicable or Manhattan may at its election apportion the deductible according to Subcontractor's contribution to the cause of the claim.

J. Release and Waiver

The Subcontractor hereby releases, and shall cause its subcontractors to release, the Contractor Parties from any and all claims or causes of action whatsoever which the Subcontractor and/or its subcontractors might otherwise now or hereafter possess resulting in or from or in any way connected with any loss covered by insurance, whether required herein or not, or which should have been covered by insurance required herein, including the deductible and/or uninsured portion thereof, maintained and/or required to be maintained by the Subcontractor and/or its subcontractors pursuant to the Contract Documents.

K. Miscellaneous

Subcontractor, or the surety of any bond required under the Subcontract from Subcontractor, shall not be relieved from any liability or obligation imposed upon either or both of them by the provisions of the Subcontract as a result of (a) any requirements of insurance from Subcontractor (b) the furnishing of any insurance by Subcontractor (c) approval of any insurance by Manhattan and/or (d) any exceptions by Manhattan to any insurance requirements.

Subcontractor ABC

Manhattan Construction Company

Subcontractor

Manhattan

Signature: _____

Signature: _____

Title: _____

Title: Senior Vice President

Printed Name: _____

Printed Name:

Date : _____

Date : _____



“OKLAHOMA RIDER”

CLARIFICATIONS/ MODIFICATION TO THE
MANHATTAN GENERAL PROVISIONS
FOR THE STATE OF OKLAHOMA

The following clarifications/modifications are hereby incorporated into the Manhattan General Provisions executed by Manhattan Construction Company and _____ *Subcontractor* dated _____ for all work in the State of Oklahoma on Subcontracts executed after _____.

- 1. Add the following after section 2.5.2

THIS INDEMNIFICATION APPLIES EVEN THOUGH THE MATTER TO BE INDEMNIFIED IS THE RESULT OF THE CONCURRENT NEGLIGENCE OF MANHATTAN, OWNER AND ARCHITECT, AND THEIR EMPLOYEES, SERVANTS, AGENTS OR OTHER SUBCONTRACTORS, PROVIDED, HOWEVER, THAT WITH RESPECT TO LIABILITY FOR DAMAGE ARISING OUT OF DEATH OR BODILY INJURY TO PERSONS, OR DAMAGE TO PROPERTY, THE INDEMNIFICATION REQUIRED OF SUBCONTRACTOR SHALL NOT EXCEED ANY AMOUNTS THAT ARE GREATER THAN THAT REPRESENTED BY THE DEGREE OR PERCENTAGE OF NEGLIGENCE OR FAULT ATTRIBUTABLE TO THE SUBCONTRACTOR, ITS AGENTS, REPRESENTATIVES, SUBCONTRACTORS OR SUPPLIERS."

“Subcontractor”
SUBCONTRACTOR COMPANY NAME

“Manhattan”
MANHATTAN CONSTRUCTION COMPANY

Signature

Signature

Printed Name

Printed Name

Title

Title

Date: _____

Date: _____

EXHIBIT "A"
SCOPE OF SUBCONTRACTOR'S WORK
FOR SUBCONTRACT AGREEMENT BETWEEN
FOREMAN MANHATTAN CONSTRUCTION TEAM AND
SUBCONTRACTOR NAME
for
CNE TAHLEQUAH CASINO
TAHLEQUAH, OK

APPLICABLE SPECIFICATIONS:

Series 0 – DOCUMENTS, complete except as hereinafter specifically excluded;
Division 1 - GENERAL REQUIREMENTS, complete except as hereinafter specifically excluded;

ADDENDUMS INCLUDED:

ALTERNATE # ACCEPTED:

GENERAL SCOPE OF WORK:

See Specification Section 01100 – Summary of Work

Includes, but is not limited to, providing all the necessary labor, materials, tools, supplies, supervision, insurance, equipment, scaffolding, hoisting, fees, etc. necessary to provide the **SCOPE ITEMS at the PROJECT NAME & LOCATION**, in accordance with the Contract Documents. It is further understood and agreed that this Subcontract also includes the furnishing and installation of the below listed items regardless of whether or not they are in the listed specification section(s) or any other specification section(s), or shown on the plans. Drawing and detail references are provided for reference only and are not to be considered as all inclusive of Contract Documents for the particular items referenced. (Please note: The word "provide" when used herein shall mean furnish and install completely, including all costs for labor, materials, equipment, hoisting, layout, scaffolding, ladders, staging, tools, rigging and any other facilities necessary to complete the work".)

- 1. XX
- 2. XXX
- 3. XXX
- 4. XXX
- 5. XXX

SCOPE OF WORK EXCLUSIONS:

The following items are excluded from this Subcontract:

- 1. XXX
- 2. XXXX

SUBCONTRACT BREAKDOWN:

Subcontract Breakdown:

Base Bid	\$ 0.00
Subcontract Total Amount	\$ 0.00

CONTRACTOR'S OPTIONS:

EXHIBIT "A"
SCOPE OF SUBCONTRACTORS WORK
CNE TAHLEQUAH CASINO
SUBCONTRACTOR NAME
PAGE 2 OF 2

At the option of Foreman Manhattan Construction Team, Subcontractor will add (or delete) the following items of work:

1. XXX
2. XXX

SPECIAL TERMS AND CONDITIONS:

1. XXXX
2. XXXX

Bond No. []
Premium []

EXHIBIT "B"
SUBCONTRACT PERFORMANCE BOND

KNOW ALL MEN BY THESE PRESENTS, that we [] As Principal and [] as Surety, are held and firmly bound unto FOREMAN-MANHATTAN CONSTRUCTION TEAM AND MANHATTAN CONSTRUCTION COMPANY AND FOREMAN CONSTRUCTION MANAGEMENT & CONSULTING are collectively and individually as Obligees, in the penal sum of [] DOLLARS \$ [] lawful money of the United States, for the payment of which sum well and truly, to be made, we bind ourselves, our heirs, executors, administrators, successors and assigns, jointly and severally, firmly by these presents.

THE CONDITION OF THE OBLIGATION IS SUCH, That whereas, the Principal entered into a Subcontract with the Obligees dated [], which is incorporated herein and made a part hereof, For [] being part of the work covered by a contract dated on or about [02/21/2018] Between [Cherokee Nation Entertainment, LLC.] hereinafter called Owner, and the said Obligees for [] which contract and the plans, specifications and general conditions thereof are hereby incorporated herein and shall be deemed a part hereof as fully as if set out herein.

NOW, THEREFORE, if the said Principal shall fully indemnify and save harmless the Obligees from all loss, liability, costs, damages, penalty, attorneys' fees or expense which Obligees may incur by reason of failure to well and truly keep, perform and fulfill each, every and all of the terms and conditions of said Subcontract on the part of the said Principal to be kept, performed and fulfilled, including but not limited to completion within the time specified of all work covered by said Subcontract, performance and fulfillment of all obligations and guarantees of the Obligees relating to such work under the contract with the Owner; then this obligation shall be of no effect, but otherwise it shall remain in full force and effect.

It is a condition hereof that any change, alteration, modification or amendment of any nature whatsoever that may be made in the terms of said Subcontract, any change in the character or scope of the work to be performed, or the method of performance, under said Subcontract or modification of said Subcontract or in the time for completion thereof, any change in the manner, time or amount of payment as provided therein, any change of any nature whatsoever that may be made in the terms of the contract between the said Obligees and the Owner or any change that may be made in the performance of the work under said Subcontract by the Principal, assented to by the Obligees, whether made under express agreement or not, may be made without notice to the surety and without affecting the obligations of the Surety on this bond and without requiring the consent of the Surety, and no such change or changes shall release the Surety from any of its obligations hereunder, the Surety hereby consenting to and waiving notice of any such change, alteration, modification or amendment. In addition, the penal sum of this Bond shall automatically increase as the Subcontract amount increases provided however that the penal sum shall not increase more than 25% above any previously established amount absent written consent from Surety and such consent shall not be unreasonably withheld.

It is a further condition hereof that no one other than the named Obligees and the successors, administrators, or assigns of the Obligees shall have any right to action under this bond.

IN WITNESS WHEREOF, the said Principal and Surety have hereunto set their hands and seals, this [] day of [], 20[].

ATTEST: []
[] (Principal) [] (Seal)
By [] (Name and Title)
[] (Signature)

WITNESS: []
[] (Surety) [] (Seal)
By [] (Name and Title)
[] (Signature)

FOREMAN | MANHATTAN Construction Team

Bond No.
Premium

EXHIBIT "B" SUBCONTRACT PAYMENT BOND

KNOW ALL MEN BY THESE PRESENTS, that we As Principal and as Surety, are held and firmly bound unto FOREMAN-MANHATTAN CONSTRUCTION TEAM AND MANHATTAN CONSTRUCTION COMPANY AND FOREMAN CONSTRUCTION MANAGEMENT & CONSULTING as Obligee, in the penal sum of

DOLLARS \$ lawful money of the United States, for the payment of which sum well and truly, to be made, we bind ourselves, our heirs, executors, administrators, successors and assigns, jointly and severally, firmly by these presents.

THE CONDITION OF THE OBLIGATION IS SUCH, That whereas, the Principal entered into a Subcontract with the Obligee dated , which is incorporated herein and made a part hereof, For

being part of the work covered by a contract dated on or about 02/21/2018 Between Cherokee Nation Entertainment, LLC.

hereinafter called Owner, and the said Obligee for which contract and the plans, specifications and general conditions thereof are hereby incorporated herein and shall be deemed a part hereof as fully as if set out herein.

NOW, THEREFORE, if the said Principal shall pay promptly and in full the claims of all persons, firms or corporations, performing labor or furnishing equipment, materials, or supplies incurred in connection with the contract to be performed and fulfilled under said Subcontract, and shall indemnify and save harmless the Obligee from all loss, liability, costs, damages, penalty, attorneys' fees or expenses for all taxes, insurance premiums, any and all applicable contributions, allowances or other payments or deductions, however termed, required by statute or union labor agreement, including voluntary payment thereof by the Obligee necessary to insure orderly prosecution of work or other items or services used in, upon or for or incurred in connection with the contract to be performed under said Subcontract, then this obligation shall be of no effect, but otherwise it shall remain in full force and effect.

It is a condition hereof that any change, alteration, modification or amendment of any nature whatsoever that may be made in the terms of said Subcontract, any change in the character or scope of the work to be performed, or the method of performance, under said Subcontract or modification of said Subcontract or in the time for completion thereof, any change in the manner, time or amount of payment as provided therein, any change of any nature whatsoever that may be made in the terms of the contract between the said Obligee and the Owner or any change that may be made in the performance of the work under said Subcontract by the Principal, assented to by the Obligee, whether made under express agreement or not, may be made without notice to the Surety and without affecting the obligations of the Surety on this bond and without requiring the consent of the Surety, and no such change or changes shall release the Surety from any of its obligations hereunder, the Surety hereby consenting to and waiving notice of any such change, alteration, modification or amendment. In addition, the penal sum of this Bond shall automatically increase as the Subcontract amount increases provided however that the penal sum shall not increase more than 25% above any previously established amount absent written consent from Surety and such consent shall not be unreasonably withheld.

Subject to the priority of the named Obligee with respect to recovery up to the penal sum of this bond, persons who have supplied or furnished labor, material, machinery, equipment or supplies to the Principal for the use in the prosecution of the work provided for in said Subcontract shall have a direct right of action against said Principal and Surety under this bond.

IN WITNESS WHEREOF, the said Principal and Surety have hereunto set their hands and seals, this day of , 20.

ATTEST:

(Principal) (Seal)
By
(Name and Title)

(Signature)

WITNESS:

(Surety) (Seal)
By
(Name and Title)

(Signature)

Construction Team Exhibit C

FOREMAN - MANHATTAN CONSTRUCTION TEAM SUBCONTRACTOR'S MINIMUM INSURANCE REQUIREMENTS

*****PLEASE REVIEW SUBCONTRACTOR MGP INSURANCE RIDER FOR COMPLETE CONTRACTUAL INSURANCE REQUIREMENTS*****

IT IS THE RESPONSIBILITY OF SUBCONTRACTOR AND THEIR AGENT TO MAKE SURE THEIR INSURANCE MEETS THEIR CONTRACTUAL OBLIGATIONS

PROJECT: Cherokee Nation Entertainment Tahlequah Casino
PROJECT NUMBER: 3882
PROJECT OWNER: Cherokee Nation Entertainment, LLC.

COMMERCIAL GENERAL LIABILITY (OCCURRENCE BASIS)

General Aggregate Limit	\$ 2,000,000
Products & Completed Operations Aggregate Limit	\$ 2,000,000
(To be carried for FOUR (4) years after completion of Project including required endorsements)	
Personal Injury Limit	\$ 1,000,000
Each Occurrence Limit	\$ 1,000,000

Aggregate Loss Limit to apply per Project (2503 Form or Equivalent)

Foreman - Manhattan Construction Team, Manhattan Construction Company, Foreman Construction Management & Consulting, Cherokee Nation Entertainment, LLC. (its parent, subsidiary, & affiliated companies), Architect (James R. Childers Architect, Inc.) and others are included as Additional Insureds (CG2010 & CG2037 Forms **or Equivalent type**).

Attached Additional Insured Endorsement(s) shall be for Ongoing and Completed Operations.

Insurance shall be Primary and Non-contributory.

Waiver of Subrogation in favor of Foreman - Manhattan Construction Team, Manhattan Construction Company, Foreman Construction Management & Consulting, Cherokee Nation Entertainment, LLC. (its parent, subsidiary, & affiliated companies), Architect (James R. Childers Architect, Inc.) and others.

BUSINESS AUTO LIABILITY

Combined Single Limit for Bodily Injury & Property Damage	\$ 1,000,000
(Above to include Owned, Hired, and Non-Owned Auto)	

Foreman - Manhattan Construction Team, Manhattan Construction Company, Foreman Construction Management & Consulting, Cherokee Nation Entertainment, LLC. (its parent, subsidiary, & affiliated companies), Architect (James R. Childers Architect, Inc.), and others to be included as Additional Insureds

WORKERS COMPENSATION/EMPLOYER'S LIABILITY

Covers **ALL** employees of the Insured in the State where work is performed.

Each Accident	\$ 1,000,000
Disease Limit – Policy	\$ 1,000,000
Disease Limit – Each Employee	\$ 1,000,000

Waiver of Subrogation in favor of Foreman - Manhattan Construction Team, Manhattan Construction Company, Foreman Construction Management & Consulting, Cherokee Nation Entertainment, LLC. (its parent, subsidiary, & affiliated companies), Architect (James R. Childers Architect, Inc.) and others

UMBRELLA LIABILITY or EXCESS POLICY (Follow Form) (OCCURRENCE BASIS)

Combined Single Limit	\$ 3,000,000
(Over/above General, Auto and Employer's Liability Limits)	

Foreman - Manhattan Construction Team, Manhattan Construction Company, Foreman Construction Management & Consulting, Cherokee Nation Entertainment, LLC. (its parent, subsidiary, & affiliated companies), Architect (James R. Childers Architect, Inc.) and others to be included as Additional Insureds.

Waiver of Subrogation in favor of Foreman - Manhattan Construction Team, Manhattan Construction Company, Foreman Construction Management & Consulting, Cherokee Nation Entertainment, LLC. (its parent, subsidiary, & affiliated companies), Architect (James R. Childers Architect, Inc.) and others. Insurance is Primary and Non-Contributory to any other available insurance to the Additional Insureds.

PROFESSIONAL LIABILITY AND POLLUTION LIABILITY– (if applicable)

Limit of Liability	\$ 2,000,000
(Must be carried for four (4) years after completion of the project)	

Foreman - Manhattan Construction Team, Manhattan Construction Company, Foreman Construction Management & Consulting, Cherokee Nation Entertainment, LLC. (its parent, subsidiary, & affiliated companies), Architect (James R. Childers Architect, Inc.) and others be included as Additional Insureds on Pollution Policy.

SAMPLE

Exhibit "C"

CERTIFICATE OF LIABILITY INSURANCE

DATE (MM/DD/YYYY)

THIS CERTIFICATE IS ISSUED AS A MATTER OF INFORMATION ONLY AND CONFERS NO RIGHTS UPON THE CERTIFICATE HOLDER. THIS CERTIFICATE DOES NOT AFFIRMATIVELY OR NEGATIVELY AMEND, EXTEND OR ALTER THE COVERAGE AFFORDED BY THE POLICIES BELOW. THIS CERTIFICATE OF INSURANCE DOES NOT CONSTITUTE A CONTRACT BETWEEN THE ISSUING INSURER(S), AUTHORIZED REPRESENTATIVE OR PRODUCER, AND THE CERTIFICATE HOLDER.

IMPORTANT: If the certificate holder is an ADDITIONAL INSURED, the policy(ies) must be endorsed. If SUBROGATION IS WAIVED, subject to the terms and conditions of the policy, certain policies may require an endorsement. A statement on this certificate does not confer rights to the certificate holder in lieu of such endorsement(s).

<p>PRODUCER</p> <p style="font-weight: bold;">****AGENTS PLEASE REVIEW SUBCONTRACTOR MGP INSURANCE RIDER FOR ALL CONTRACTUAL INSURANCE REQUIREMENTS****</p>	<p>CONTACT NAME: PHONE (A/C, No, Ext):FAX (A/C, No): E-MAIL ADDRESS: PRODUCER CUSTOMER ID #:</p> <hr/> <p style="text-align: center;">INSURER(S) AFFORDING COVERAGE</p> <p>INSURER A: INSURER B: INSURER C: INSURER D: INSURER E: INSURER F:</p> <p style="text-align: right;">NAIC #</p>
<p>INSURED</p>	

COVERAGES

CERTIFICATE NUMBER:

REVISION NUMBER:

THIS IS TO CERTIFY THAT THE POLICIES OF INSURANCE LISTED BELOW HAVE BEEN ISSUED TO THE INSURED NAMED ABOVE FOR THE POLICY PERIOD INDICATED. NOTWITHSTANDING ANY REQUIREMENT, TERM OR CONDITION OF ANY CONTRACT OR OTHER DOCUMENT WITH RESPECT TO WHICH THIS CERTIFICATE MAY BE ISSUED OR MAY PERTAIN, THE INSURANCE AFFORDED BY THE POLICIES DESCRIBED HEREIN IS SUBJECT TO ALL THE TERMS, EXCLUSIONS AND CONDITIONS OF SUCH POLICIES. LIMITS SHOWN MAY HAVE BEEN REDUCED BY PAID CLAIMS.

INSR LTR	TYPE OF INSURANCE	ADDL INSR	SUBR WVD	POLICY NUMBER	POLICY EFF (MM/DD/YYYY)	POLICY EXP (MM/DD/YYYY)	LIMITS
	GENERAL LIABILITY						EACH OCCURRENCE \$ 1,000,000
	<input checked="" type="checkbox"/> COMMERCIAL GENERAL LIABILITY						DAMAGE TO RENTED PREMISES (Ea occurrence) \$ 50,000
	<input type="checkbox"/> CLAIMS-MADE <input checked="" type="checkbox"/> OCCUR						MED EXP (Any one person) \$ 5,000
			X	X			PERSONAL & ADV INJURY \$ 1,000,000
							GENERAL AGGREGATE \$ 2,000,000
	GEN'L AGGREGATE LIMIT APPLIES PER:						PRODUCTS - COMPI/OP AGG \$ 2,000,000
	<input type="checkbox"/> POLICY <input checked="" type="checkbox"/> PRO-JECT <input type="checkbox"/> LOC						\$
	AUTOMOBILE LIABILITY						COMBINED SINGLE LIMIT (Ea accident) \$ 1,000,000
	<input checked="" type="checkbox"/> ANY AUTO						BODILY INJURY (Per person) \$
	<input type="checkbox"/> ALL OWNED AUTOS		X	X			BODILY INJURY (Per accident) \$
	<input type="checkbox"/> SCHEDULED AUTOS						PROPERTY DAMAGE (PER ACCIDENT) \$
	<input checked="" type="checkbox"/> HIRED AUTOS						\$
	<input checked="" type="checkbox"/> NON-OWNED AUTOS						\$
	UMBRELLA LIAB						EACH OCCURRENCE \$ 3,000,000
	<input checked="" type="checkbox"/> OCCUR						AGGREGATE \$ 3,000,000
	EXCESS LIAB						\$
	<input type="checkbox"/> CLAIMS-MADE	X	X				\$
	DEDUCTIBLE						\$
	RETENTION \$						\$
	WORKERS COMPENSATION AND EMPLOYERS' LIABILITY						<input checked="" type="checkbox"/> WC STATU-TORY LIMITS <input type="checkbox"/> OTH-ER
	ANY PROPRIETOR/PARTNER/EXECUTIVE OFFICER/MEMBER EXCLUDED? (Mandatory in NH)		Y / N	N / A	X		E.L. EACH ACCIDENT \$ 1,000,000
	If yes, describe under DESCRIPTION OF OPERATIONS below						E.L. DISEASE - EA EMPLOYEE \$ 1,000,000
	Professional Liability	X	X				E.L. DISEASE - POLICY LIMIT \$ 1,000,000
	Pollution Liability	X	X				\$ 2,000,000
							\$ 2,000,000

DESCRIPTION OF OPERATIONS / LOCATIONS / VEHICLES

Project Name: Cherokee Nation Entertainment Tahlequah Casino
 Project Owner : Cherokee Nation Entertainment, LLC.
 MCC Project Number: 3882

* See Notepad for additional requirements *

<p>CERTIFICATE HOLDER</p> <p>Foreman - Manhattan Construction Team 5601 S. 122nd E. Ave Tulsa, OK 74146</p>	<p>CANCELLATION</p> <p style="text-align: center;">SHOULD ANY OF THE ABOVE DESCRIBED POLICIES BE CANCELLED BEFORE THE EXPIRATION DATE THEREOF, NOTICE WILL BE DELIVERED IN ACCORDANCE WITH THE POLICY PROVISIONS.</p> <p>AUTHORIZED REPRESENTATIVE</p>
--	--

Check Correct Box

Will also require additional Insured Status in Favor of Foreman - Manhattan Construction Team, Manhattan Construction Company, Foreman Construction Management & Consulting, Cherokee Nation Entertainment, LLC. (Its parent, subsidiary, & affiliated companies), Architect (James R. Childers Architect, Inc.) and others on Pollution policy as applicable

NOTEPAD:HOLDER CODE
INSURED'S NAME**OP ID:**PAGE 2
Date

Additional Insured in favor of Foreman - Manhattan Construction Team, Manhattan Construction Company, Foreman Construction Management & Consulting, Cherokee Nation Entertainment, LLC. (its parent, subsidiary, & affiliated companies), Architect (James R. Childers Architect, Inc.) and others as required by written contract on GL, Auto & Umbrella Policies.

Additional Insured Endorsements for Ongoing and Completed Operations are attached.

Excess and/or Umbrella follows form.

All policies, including excess or umbrella policies, are primary and non-contributory to any other insurance available to the Additional Insureds.

Waiver of Subrogation in favor of Foreman - Manhattan Construction Team, Manhattan Construction Company, Foreman Construction Management & Consulting, Cherokee Nation Entertainment, LLC. (its parent, subsidiary, & affiliated companies), Architect (James R. Childers Architect, Inc.) and others as required by written contract on GL and WC Policies.

Workers Compensation Coverage covers ALL employees of the insured in the state where work is being performed.

1. The Subcontract Agreement (including all attached and referenced Exhibits).
2. Manhattan General Provisions.
3. The Agreement between Manhattan and the Owner ("Agreement").
4. General Conditions of the Contract.
5. Supplementary and other Conditions.
6. Exhibits and Riders enumerated and attached to the Agreement.
7. All Addenda issued prior to and all modifications issued after execution of the Agreement.
8. Alternates as selected and incorporated herein.
9. Unit Prices.
10. Plans and Specifications as follows:

BIDDING & CONTRACTING REQUIREMENTS: Bid and Contracting Manual, as prepared by Manhattan Construction, dated April 23, 2018

GEOTECH REPORT: CNE Tahlequah Casino as prepared by Building & Earth (*Project No. OK170293*) dated January 17th, 2018

SPECIFICATIONS:

CNE Tahlequah Casino Bid Package 01: As prepared by James R. Childers dated March 6th, 2018
CNE Tahlequah Casino Bid Package 02: As prepared by James R. Childers dated March 27th, 2018
CNE Tahlequah Casino Bid Package 03: As prepared by James R. Childers dated April 16th, 2018
CNE Tahlequah Casino Bid Package 04: As prepared by James R. Childers dated April 20th, 2018
CNE Tahlequah Casino Bid Package 05: As prepared by James R. Childers dated May 3rd, 2018

DRAWINGS:

CNE Tahlequah Casino Bid Package 01: As prepared by James R. Childers dated March 6th, 2018
CNE Tahlequah Casino Bid Package 02: As prepared by James R. Childers dated March 27th, 2018
CNE Tahlequah Casino Bid Package 03: As prepared by James R. Childers dated April 16th, 2018
CNE Tahlequah Casino Bid Package 04: As prepared by James R. Childers dated April 20th, 2018
CNE Tahlequah Casino Bid Package 05: As prepared by James R. Childers dated May 3rd, 2018

SWPPP: CNE Tahlequah Casino as prepared by ADG dated March 6th, 2018

ADDENDA/AMENDMENTS:

Addendum #001: As prepared by James R. Childers dated April 9th, 2018
Addendum #002: As prepared by James R. Childers dated April 9th, 2018
Addendum #003: As prepared by James R. Childers dated April 16th, 2018
Addendum #004: As prepared by James R. Childers dated April 18th, 2018
Addendum #005: As prepared by James R. Childers dated April 27th, 2018
Addendum #006: As prepared by James R. Childers dated May 4th, 2018
Addendum #007: As prepared by James R. Childers dated May 8th, 2018
Addendum #008: As prepared by James R. Childers dated May 11th, 2018

MCC CLARIFICATIONS:

MCC Clarification #001:	3/27/18
MCC Clarification #002:	3/28/18
MCC Clarification #003:	4/6/18
MCC Clarification #004:	4/9/18
MCC Clarification #005:	4/16/18
MCC Clarification #006:	4/19/18
MCC Clarification #007:	4/25/18
MCC Clarification #008:	5/7/18

BID PACKAGE 01 (March 6, 2018)

SPECIFICATIONS

DIVISION 00 – Procurement Requirements and Contracting Requirements

00 0102 – Project Information
00 0105 – Geotechnical Data

DIVISION 01 – General Requirements

DIVISION 03 – Concrete

03 3000 – Cast in Place Concrete

DIVISION 31 – EARTHWORK

31 2000 – Earthwork
31 2319 – Dewatering
31 2500 – Erosion and Sedimentation Control
31 5000 – Excavation Support and Protection
31 6329 – Drilled Concrete Piers and Shafts

DIVISION 32 – SITE IMPROVEMENTS

Section 32 9200 – Turf and Grasses
32 9200 – Turf and Grasses

DIVISION 33 – UTILITIES

Section 33 5100 – Private Storm Sewer

Geotechnical Engineering Report by Building & Earth Sciences, Inc. dated January 17, 2018

DRAWINGS

COVER

ABBREVIATIONS, SYMBOLS, & INDEX

SURVEY

CIVIL

C0.01a INDEX AND GENERAL CONSTRUCTION NOTES
C0.02a PLAT OF TOPOGRAPHIC MAPPING (1 OF 2)
C0.03a PLAT OF TOPOGRAPHIC MAPPING (2 OF 2)
C1.00a CIVIL SITE PLAN – OVERVIEW

C1.02a CIVIL SITE PLAN
C2.02a UTILITY PLAN INDEX
C3.02a EROSION CONTROL PLAN
C5.05a STORM SEWER LINE A - PLAN AND PROFILE
C5.10a STORM SEWER LINE A - PLAN AND PROFILE (CONT)
C8.02a ROUGH GRADING PLAN
C9.00a CIVIL CONSTRUCTION DETAILS
C9.05a CIVIL CONSTRUCTION DETAIL

STRUCTURE

S1.1 FOUNDATION PLAN OVERALL
S1.2 FOUNDATION PLAN AREA A
S1.3 FOUNDATION PLAN AREA B
S1.4 FOUNDATION PLAN AREA C

MECHANICAL

MSK-001 MECHANICAL SCHEDULES
MSK-002 MECHANICAL ROOF PLAN

ELECTRICAL

ESK-002 ELECTRICAL EXHIBITS

FOOD SERVICE

FS101 FOODSERVICE EQUIPMENT ARRANGMENT PLAN
FS102 FOODSERVICE EQUIPMENT ARRANGMENT PLAN
FS103 FOODSERVICE EQUIPMENT ARRANGMENT PLAN
FS104 FOODSERVICE EQUIPMENT ARRANGMENT PLAN
FS105 FOODSERVICE EQUIPMENT ARRANGMENT PLAN
FS106 FOODSERVICE EQUIPMENT SLAB RECESS PLAN
FS107 FOODSERVICE EQUIPMENT SLAB RECESS PLAN
FS108 FOODSERVICE EQUIPMENT SLAB RECESS PLAN
FS109 FOODSERVICE EQUIPMENT SLAB RECESS PLAN
FS110 FOODSERVICE EQUIPMENT SLAB RECESS PLAN

BID PACKAGE 02 (March 27, 2018)

SPECIFICATIONS

DIVISION 07 – THERMAL AND MOISTURE PROTECTION

07 1300 – Sheet Waterproofing
07 2100 – Thermal Insulation

DIVISION 22 – PLUMBING

22 1113 – Water Distribution
22 1313 – Private Sanitary Sewerage
22 1316 – Sanitary Waste and Vent Piping

DIVISION 23 – HEATING, VENTING, AND AIR CONDITIONING

23 6500 – Closed Circuit Cooling Tower
23 7313 – Central Station Air Handling Units
23 7313.1 – Central Station Air Handling Units

DIVISION 26 – ELECTRICAL

26 0519 – Low Voltage Electrical Power Conductors and Cables
26 0526 – Grounding and Bonding for Electrical Systems
26 0529 – Hangers and Supports for Electrical Systems
26 0533 – Raceways and Boxes for Electrical Systems
26 0543 – Underground Ducts and Raceways for Electrical Systems
26 0544 – Sleeves and Sleeve Seals for Electrical Raceways and Cabling

26 4113 – Lighting Protection for Structures

DIVISION 31 – EARTHWORK

31 3116 – Termite Control

DRAWINGS

COVER

ABBREVIATIONS, SYMBOLS, & INDEX

CIVIL

C0.01b INDEX AND GENERAL CONSTRUCTION NOTES
C0.02b PLAT OF TOPOGRAPHIC MAPPING (1 OF 2)
C0.03b PLAT OF TOPOGRAPHIC MAPPING (2 OF 2)
C2.02b UTILITY PLAN INDEX
C6.02b SANITARY SEWER INDEX
C6.05b SANITARY SEWER PLAN AND PROFILE - LINE A
C6.10b SANITARY SEWER PLAN AND PROFILE - LINE A (CONT)
C6.15b SANITARY SEWER PLAN AND PROFILE - LINE A (CONT)
C6.20b SANITARY SEWER PLAN AND PROFILE - LINE A (CONT)
C6.25b SANITARY SEWER PLAN AND PROFILE - LINE B
C6.30b SANITARY SEWER PLAN AND PROFILE - LINE B (CONT)
C7.02b WATER INDEX
C7.05b WATER LINE PLAN AND PROFILE - LINE A
C7.10b WATER LINE PLAN AND PROFILE - LINE A (CONT)
C7.15b WATER LINE PLAN AND PROFILE - LINE B
C7.20b WATER LINE PLAN AND PROFILE - LINE B (CONT)
C7.25b WATER LINE PLAN AND PROFILE - LINE C
C7.30b WATER LINE PLAN AND PROFILE - LINE D
C7.35b WATER LINE PLAN AND PROFILE - LINE D (CONT)
C9.10b CIVIL CONSTRUCTION DETAILS
C9.15b CIVIL CONSTRUCTION DETAILS
C9.20b CIVIL CONSTRUCTION DETAILS

STRUCTURE

S0.1 STRUCTURAL NOTES
S1.1 FOUNDATION PLAN OVERALL
S1.2 FOUNDATION PLAN AREA A
S1.3 FOUNDATION PLAN AREA B
S1.4 FOUNDATION PLAN AREA C
S2.1 SLAB PLAN
S3.1 ROOF FRAMING PLANS
S3.2 ROOF FRAMING PLANS
S3.3 ROOF FRAMING PLANS
S3.4 SAFER ROOMS FRAMING PLANS
S3.5 SNOW DRIFT PLANS
S4.1 BUILDING SECTIONS
S4.2 FRAME ELEVATIONS
S4.3 FRAME ELEVATIONS

PLUMBING

PU0.0 PLUMBING COVERSHEET AND INDEX
PU1.1 PLUMBING ENLARGED UNDERSLAB PLAN – GAMING
PU1.2 PLUMBING ENLARGED UNDERSLAB PLAN – SOUTH
PU1.3 PLUMBING ENLARGED UNDERSLAB PLAN – BOH
PU1.4 PLUMBING ENLARGED UNDERSLAB PLAN - BANQUET BOH
PU1.5 PLUMBING ENLARGED UNDERSLAB PLAN – NORTH

ELECTRICAL

E0.0 SYMBOL LIST
E0.1 GENERAL NOTES
E0.2 SINGLE LINE AND FOOD SERVICE SYSTEM NOTES
E0.3 SCHEDULES
E0.4 ELECTRICAL DIAGRAM
E0.10 SINGLE LINE DIAGRAM - MAIN SERVICE SWITCHBOARD 'TCMSA'
E0.11 PARTIAL SINGLE LINE DIAGRAM
E0.12 SINGLE LINE DIAGRAM - MAIN SERVICE SWITCHBOARD 'TCMSB'
E0.13 PARTIAL SINGLE LINE DIAGRAM
E0.14 PARTIAL SINGLE LINE DIAGRAM
E0.40 LIGHTING FIXTURE SCHEDULE
E1.0 ELECTRICAL OVERVIEW PLAN
E1.1 ENLARGED POWER PLAN – GAMING
E3.1 ENLARGED ELECTRICAL ROOM PLAN
E3.2 ENLARGED ELECTRICAL ROOM PLANS
EFS112 FOODSERVICE ELECTRICAL CONNECTION PLAN
EFS113 FOODSERVICE ELECTRICAL CONNECTION PLAN
EFS115 FOODSERVICE ELECTRICAL CONNECTION PLAN
ES1.0 ELECTRICAL SITE PLAN
ES1.0A ELECTRICAL SITE PLAN - CCTV INFRASTRUCTURE

FOOD SERVICE

FS100 FOODSERVICE EQUIPMENT OVERVIEW
FS101 FOODSERVICE EQUIPMENT ARRANGMENT PLAN
FS102 FOODSERVICE EQUIPMENT ARRANGMENT PLAN
FS103 FOODSERVICE EQUIPMENT ARRANGMENT PLAN
FS104 FOODSERVICE EQUIPMENT ARRANGMENT PLAN
FS105 FOODSERVICE EQUIPMENT ARRANGMENT PLAN
FS106 FOODSERVICE EQUIPMENT SPECIAL COND. PLAN
FS107 FOODSERVICE EQUIPMENT SPECIAL COND. PLAN
FS108 FOODSERVICE EQUIPMENT SPECIAL COND. PLAN
FS109 FOODSERVICE EQUIPMENT SPECIAL COND. PLAN
FS110 FOODSERVICE EQUIPMENT SLAB RECESS PLAN
FS111 FOODSERVICE EQUIPMENT PRELIM. MEP CONNECTION PLAN
FS112 FOODSERVICE EQUIPMENT PRELIM. MEP CONNECTION PLAN
FS113 FOODSERVICE EQUIPMENT PRELIM. MEP CONNECTION PLAN
FS114 FOODSERVICE EQUIPMENT PRELIM. MEP CONNECTION PLAN
FS115 FOODSERVICE EQUIPMENT PRELIM. MEP CONNECTION PLAN
FS116 FOODSERVICE EQUIPMENT PRELIM. MEP CONNECTION PLAN

LOW VOLTAGE

ITS101 LOW VOLTAGE CONDUIT PLAN
ITS102 LOW VOLTAGE CONDUIT PLAN

BID PACKAGE 03 (April 16, 2018)

SPECIFICATIONS

DIVISION 03 - CONCRETE

03 4500 PRECAST ARCHITECTURAL CONCRETE

DIVISION 04 - MASONRY

04 4301 STONE MASONRY VENEER DIVISION

05 - METALS

05 1200 STRUCTURAL STEEL FRAMING

05 5150 FIXED METAL LADDERS

DIVISION 06 - WOOD, PLASTICS, AND COMPOSITES

06 1000 ROUGH CARPENTRY
06 1110 WOOD BLOCKING AND CURBING

DIVISION 07 - THERMAL AND MOISTURE PROTECTION

07 1300 SHEET WATERPROOFING
07 1310 WATER REPELLENTS
07 2100 THERMAL INSULATION
07 2119 FOAMED-IN-PLACE INSULATION
07 2120 POLYISOCYANURATE INSULATION
07 2400 EXTERIOR INSULATION AND FINISH SYSTEMS
07 2510 FLUID APPLIED VAPOR PERMEABLE AIR BARRIER MEMBRANE
07 4113 METAL ROOF PANELS
07 4213 METAL WALL PANELS
07 4600 FIBER CEMENT SIDING
07 5200 MODIFIED BITUMINOUS MEMBRANE ROOFING
07 6200 SHEET METAL FLASHING AND TRIM
07 8100 APPLIED FIREPROOFING
07 8400 FIRESTOPPING
07 9000 JOINT SEALERS

DIVISION 08 - OPENINGS

08 1113 HOLLOW METAL DOORS AND FRAMES
08 3323 OVERHEAD COILING DOORS
08 4229 AUTOMATIC ENTRANCES
08 4233 REVOLVING DOOR ENTRANCES
08 4300 ALUMINUM STOREFRONT ENTRANCES
08 4310 ALUMINUM STOREFRONT WINDOW SYSTEMS
08 4400 GLAZED ALUMINUM CURTAIN WALL SYSTEMS3
08 7100 DOOR HARDWARE
08 8150 GLASS

DIVISION 09 – FINISHES

09 2116 GYPSUM BOARD ASSEMBLIES
09 5100 ACOUSTICAL CEILINGS
09 9000 PAINTINGS AND COATINGS

DIVISION 10 – SPECIALTIES

10 2226 OPERABLE PARTITIONS
10 7500 FLAGPOLES
10 8200 ROOF TOP EQUIPMENT SCREENS

DIVISION 11 - EQUIPMENT

11 1313 LOADING DOCK BUMPERS
11 1316 LOADING DOCK SEALS AND SHELTERS
11 1319.13 LOADING DOCK LEVELERS

DRAWINGS

COVER

ABBREVIATIONS, SYMBOLS, & INDEX

ARCHITECTURE

A1.0 OVERALL FLOOR PLAN
A1.1 ENLARGED FLOOR PLAN - GAMING

A1.2 ENLARGED FLOOR PLAN - SOUTH
A1.3 ENLARGED FLOOR PLAN - BOH
A1.4 ENLARGED FLOOR PLAN - BANQUET BOH
A1.5 ENLARGED FLOOR PLAN - NORTH
A1.11 PARTITION TYPES
A1.12 PARTITION TYPES & DETAILS
A2.0 EXTERIOR ELEVATIONS
A3.0 BUILDING SECTIONS
A3.1 WALL SECTIONS
A3.2 WALL SECTIONS
A3.3 WALL SECTIONS
A3.4 WALL SECTIONS
A3.5 WALL SECTIONS
A3.6 WALL SECTIONS
A3.7 WALL SECTION DETAILS
A3.8 COLUMN DETAILS & PRECAST PROFILES
A3.9 PLAN DETAILS
A4.0 ROOF PLAN
A5.0 DOOR SCHEDULE DOOR AND WINDOW ELEVATIONS
A5.1 STOREFRONT ELEVATIONS
A5.2 STOREFRONT DETAILS
A6.0 OVERALL REFLECTED CEILING PLAN
A6.0 REFLECTED CEILING PLAN - GAMING
A6.0 REFLECTED CEILING PLAN - SOUTH
A6.0 REFLECTED CEILING PLAN - BOH
A6.0 REFLECTED CEILING PLAN - BANQUET BOH
A6.0 REFLECTED CEILING PLAN - NORTH
A7.0 MISCELLANEOUS DETAILS

BID PACKAGE 04 (April 20, 2018)

SPECIFICATIONS

DIVISION 32 – EXTERIOR IMPROVEMENTS

32 1216 ASPHALT PAVING
32 1313 CONCRETE PAVING
32 1373 CONCRETE PAVING JOINT SEALANTS
32 1723 PAVEMENT MARKINGS
32 3113 CHAIN LINK FENCES AND GATES

DRAWINGS

COVER
ABBREVIATIONS, SYMBOLS, & INDEX
CIVIL
C0.01c INDEX AND GENERAL CONSTRUCTION NOTES
C0.02c PLAT OF TOPOGRAPHIC MAPPING (1 OF 2)
C0.03c PLAT OF TOPOGRAPHIC MAPPING (2 OF 2)
C1.00c CIVIL SITE PLAN - OVERVIEW
C1.02c CIVIL SITE PLAN INDEX
C1.05c CIVIL SITE PLAN - AREA 05
C1.10c CIVIL SITE PLAN - AREA 10
C1.15c CIVIL SITE PLAN - AREA 15
C1.20c CIVIL SITE PLAN - AREA 20
C1.25c CIVIL SITE PLAN - AREA 25
C1.30c CIVIL SITE PLAN - AREA 30
C1.35c CIVIL SITE PLAN - AREA 35
C1.40c CIVIL SITE PLAN - AREA 40

C1.45c CIVIL SITE PLAN - AREA 45
C3.02c EROSION CONTROL PLAN
C4.00c PRE-DEVELOPMENT DRAINAGE MAP - OVERVIEW
C4.05c POST-DEVELOPMENT DRAINAGE MAP - OVERVIEW
C4.10c POST-DEVELOPMENT DRAINAGE MAP - INSET
C8.02c FINISHED GRADING PLAN - INDEX
C8.05c FINISHED GRADING PLAN - AREA 05
C8.10c FINISHED GRADING PLAN - AREA 10
C8.15c FINISHED GRADING PLAN - AREA 15
C8.20c FINISHED GRADING PLAN - AREA 20
C8.25c FINISHED GRADING PLAN - AREA 25
C8.30c FINISHED GRADING PLAN - AREA 30
C8.35c FINISHED GRADING PLAN - AREA 35
C8.40c FINISHED GRADING PLAN - AREA 40
C8.45c FINISHED GRADING PLAN - AREA 45
C9.05c CIVIL CONSTRUCTION DETAILS
C9.10c CIVIL CONSTRUCTION DETAILS
C9.15c CIVIL CONSTRUCTION DETAILS
C9.20c CIVIL CONSTRUCTION DETAILS

BID PACKAGE 05 (May 3, 2018)

SPECIFICATIONS

DIVISION 6 –WOODS, PLASTICS AND COMPOSITES

06 2000 FINISH CARPENTRY
06 4100 ARCHITECTURAL WOOD CASEWORK
06 8300 HIGH PRESSURE DECORATIVE LAMINATES

DIVISION 8 –OPENINGS

08 1416 FLUSH WOOD DOORS
08 3100 ACCESS DOORS & PANELS
08 3313 COILING COUNTER DOORS
08 3323 OVERHEAD COILING DOORS

DIVISION 9 –FINISHES

09 3050 TILE
09 6500 RESILIENT FLOORING & BASE
09 6813 TILE CARPETING
09 6900 ACCESS FLOORING
09 9100 PAINTS AND COATINGS
09 9600 RESINOUS FLOOR COATINGS

DIVISION 10 –SPECIALTIES

10 2113.19 PLASTIC TOILET COMPARTMENTS
10 2601 WALL AND CORNER GUARDS
10 2615 HIGH IMPACT WALL COVERING
10 2800 TOILET ACCESSORIES
10 4400 FIRE PROTECTION SPECIALTIES
10 5100 LOCKERS

DIVISION 11 –EQUIPMENT

11 4000 FOODSERVICE EQUIPMENT

DIVISION 22 – PLUMBING

22 05 13 COMMON MOTOR REQUIREMENTS FOR PLUMBING EQUIPMENT
22 05 16 EXPANSION FITTINGS AND LOOPS FOR PLUMBING PIPING
22 05 17 SLEEVES AND SLEEVE SEALS FOR PLUMBING PIPING

22 05 18 ESCUTCHEONS FOR PLUMBING PIPING
22 05 19 METERS AND GAGES FOR PLUMBING PIPING
22 05 23 GENERAL-DUTY VALVES FOR PLUMBING PIPING
22 05 29 HANGERS AND SUPPORTS FOR PLUMBING PIPING AND EQUIPMENT
22 05 48 VIBRATION AND SEISMIC CONTROLS FOR PLUMBING PIPING AND EQUIPMENT
22 05 53 IDENTIFICATION FOR PLUMBING PIPING AND EQUIPMENT
22 07 16 PLUMBING EQUIPMENT INSULATION
22 07 19 PLUMBING PIPING INSULATION
22 08 00 COMMISSIONING OF PLUMBING SYSTEMS
22 11 16 DOMESTIC WATER PIPING
22 11 19 DOMESTIC WATER PIPING SPECIALITIES
22 11 23 DOMESTIC WATER PUMPS
22 13 16 SANITARY WASTE AND VENT PIPING
22 13 19 SANITARY WASTE PIPING SPECIALITIES
22 42 13.13 COMMERCIAL WATER CLOSETS
22 42 13.16 COMMERCIAL URINALS
22 42 16.13 COMMERCIAL LAVATORIES
22 42 16.16 COMMERCIAL SINKS
22 47 16 PRESSURE WATER COOLERS

DIVISION 23 – HEATING VENTILATING AND AIR-CONDITIONING (HVAC)

23 00 01 HVAC GENERAL REQUIREMENTS
23 00 02 BASIC HVAC MATERIALS AND METHODS
23 05 16 PIPE EXPANSION FITTINGS AND LOOPS
23 05 18 ESCUTCHEONS FOR HVAC PIPING
23 05 19 HVAC METERS AND GAGES
23 05 23 VALVES
23 05 29 HANGERS AND SUPPORTS
23 05 48 HVAC VIBRATION CONTROLS
23 05 53 MECHANICAL IDENTIFICATION
23 05 93 TESTING, ADJUSTING, AND BALANCING
23 07 13 DUCT INSULATION
23 07 17 EQUIPMENT INSULATION
23 07 19 HVAC PIPE INSULATION
23 08 00 COMMISSIONING OF HVAC SYSTEMS
23 09 00 AUTOMATIC TEMPERATURE CONTROL SYSTEMS
23 09 93 SEQUENCE OF OPERATIONS
23 21 13 HYDRONIC PIPING
23 21 23 HYDRONIC PUMPS
23 23 00 REFRIGERANT PIPING
23 25 00 HVAC WATER TREATMENT
23 31 13 HVAC DUCTS
23 33 0 DUCT ACCESSORIES
23 34 23 HVAC POWER VENTILATORS
23 36 00 AIR TERMINAL UNITS
23 37 13 DIFFUSERS, REGISTERS, AND GRILLES
23 51 00 BREECHINGS, CHIMNEYS, AND STACKS
23 52 16 CONDENSING BROILERS
23 64 18.1 MODULAR CENTRAL PLANT
23 65 00 CLOSED CIRCUIT COOLERS
23 73 13 AIR-HANDLING UNIT
23 73 13.1 AIR HANDLING UNIT / DEDICATED OUTDOOR AIR SYSTEM / ENERGY RECOVERY UNIT
23 82 19 FAN -COIL UNITS
23 82 39 UNIT HEATERS

DIVISION 26 – ELECTRICAL

26 05 19 LOW-VOLTAGE ELECTRICAL POWER CONDUCTORS AND CABLES
26 05 26 GROUNDING AND BONDING FOR ELECTRICAL SYSTEMS

26 05 29 HANGERS AND SUPPORTS FOR ELECTRICAL SYSTEMS
26 05 33 RACEWAYS AND BOXES FOR ELECTRICAL SYSTEMS
26 05 43 UNDERGROUND DUCTS AND RACEWAYS FOR ELECTRICAL SYSTEMS
26 05 44 SLEEVES AND SLEEVE SEALS FOR ELECTRICAL RACEWAYS AND CABLING
26 05 53 IDENTIFICATION FOR ELECTRICAL SYSTEMS
26 05 72 OVERCURRENT PROTECTIVE DEVICE SHORT-CIRCUIT STUDY
26 05 73 OVERCURRENT PROTECTIVE DEVICE COORDINATION STUDY
26 05 74 OVERCURRENT PROTECTIVE DEVICE ARC-FLASH STUDY
26 22 00 LOW-VOLTAGE TRANSFORMERS
26 24 13 SWITCHBOARDS
26 24 16 PANELBOARDS
26 27 26 WIRING DEVICES
26 28 13 FUSES
26 28 16 ENCLOSED SWITCHES AND CIRCUIT BREAKERS
26 29 13.03 MANUAL AND MAGNETIC MOTOR CONTROLLERS
26 32 13.13 DIESEL EMERGENCY ENGINE GENERATORS
26 33 53 STATIC UNINTERRUPTIBLE POWER SUPPLY
26 36 00 TRANSFER SWITCHES
26 41 13 LIGHTNING PROTECTION FOR STRUCTURES
26 51 19 LED INTERIOR LIGHTING
26 52 19 EMERGENCY AND EXIT LIGHTING
26 56 13 LIGHT POLES AND STANDARDS
26 56 19 LED EXTERIOR LIGHTING

DIVISION 28 – ELECTRONIC SAFETY AND SECURITY

28 31 11 DIGITAL, ADDRESSABLE FIRE ALARM AND EMERGENCY COMMUNICATIONS SYSTEM

DRAWINGS

COVER

ABBREVIATIONS, SYMBOLS, & INDEX

LANDSCAPE

L1.1 LANDSCAPE PLAN
L1.2 LANDSCAPE PLAN
L1.3 LANDSCAPE PLAN
L1.4 LANDSCAPE PLAN
L1.5 LANDSCAPE PLAN
L1.6 IRRIGATION NOTES AND DETAILS

ARCHITECTURE

A1.0 OVERALL FLOOR PLAN
A1.1 ENLARGED FLOOR PLAN - GAMING
A1.2 ENLARGED FLOOR PLAN - SOUTH
A1.3 ENLARGED FLOOR PLAN - BOH
A1.4 ENLARGED FLOOR PLAN - BANQUET BOH
A1.5 ENLARGED FLOOR PLAN - NORTH
A1.6 ENLARGED FLOOR PLAN - CANOPY
A1.7 ENLARGED FLOOR PLAN - CANOPY
A1.8 ENLARGED TOILET PLANS
A1.9 ENLARGED TOILET PLANS
A1.10 ENLARGED TOILET PLANS
A1.11 PARTITION TYPES
A1.12 PARTITION TYPES & DETAILS
A1.13 FINISH SCHEDULE
A2.0 EXTERIOR ELEVATIONS
A2.1 TOILET ELEVATIONS
A2.2 TOILET ELEVATIONS

A2.3 TOILET ELEVATIONS
A2.4 TOILET ELEVATIONS
A2.5 TOILET ELEVATIONS
A2.6 TOILET ELEVATIONS
A2.7 TOILET AND EVS ELEVATIONS
A2.8 INTERIOR ELEVATIONS
A2.9 INTERIOR ELEVATIONS
A2.10 INTERIOR ELEVATIONS
A2.11 INTERIOR ELEVATIONS
A2.12 INTERIOR ELEVATIONS
A2.13 INTERIOR ELEVATIONS
A2.14 INTERIOR ELEVATIONS
A2.15 INTERIOR ELEVATIONS
A2.16 INTERIOR ELEVATIONS
A2.17 INTERIOR ELEVATIONS
A3.0 BUILDING SECTIONS
A3.1 WALL SECTIONS
A3.2 WALL SECTIONS
A3.3 WALL SECTIONS
A3.4 WALL SECTIONS
A3.5 WALL SECTIONS
A3.6 WALL SECTIONS
A3.7 STAGE SECTIONS
A3.8 CANOPY SECTIONS
A3.9 WALL SECTION DETAILS
A3.10 CANOPY SECTIONS
A3.11 CANOPY SECTION DETAILS
A3.12 COLUMN DETAILS & PRECAST PROFILES
A3.13 PLAN DETAILS
A4.0 ROOF PLAN
A5.0 DOOR SCHEDULE DOOR & WINDOW ELEVATIONS
A5.1 STOREFRONT ELEVATIONS
A5.2 STOREFRONT DETAILS
A6.0 OVERALL REFLECTED CEILING PLAN
A6.1 ENLARGED REFLECTED CEILING PLAN - GAMING
A6.2 ENLARGED REFLECTED CEILING PLAN - SOUTH
A6.3 ENLARGED REFLECTED CEILING PLAN - BOH
A6.4 ENLARGED REFLECTED CEILING PLAN - BANQUET HALL BOH
A6.5 ENLARGED REFLECTED CEILING PLAN - NORTH
A6.6 OVERALL FLOOR COVERING PLAN
A6.7 ENLARGED FLOOR COVERING PLAN - GAMING
A6.8 ENLARGED FLOOR COVERING PLAN - SOUTH
A6.9 ENLARGED FLOOR COVERING PLAN - BOH
A6.10 ENLARGED FLOOR COVERING PLAN - BANQUET HALL BOH
A6.11 ENLARGED FLOOR COVERING PLAN - NORTH
A7.0 MISCELLANEOUS DETAILS
A8.0 MILLWORK PLANS & ELEVATIONS
A8.1 MILLWORK PLANS & ELEVATIONS
A8.2 MILLWORK PLANS & ELEVATIONS
A8.3 MILLWORK PLANS & ELEVATIONS
A8.4 MILLWORK PLANS & ELEVATIONS
A8.5 MILLWORK PLANS & ELEVATIONS
A8.6 MILLWORK PLANS & ELEVATIONS
A9.0 OVERALL LIFE SAFETY PLAN
A9.1 LIFE SAFETY PLAN
A11.0 EVACUATION PLAN

STRUCTURAL

S1.8 PORTE COCHERE FOUNDATION PLANS
S3.7 PORTE COCHERE FRAMING PLAN
S3.8 PORTE COCHERE FRAMING PLAN
S4.4 PORTE COCHERE SECTIONS
S4.5 PORTE COCHERE SECTIONS
S4.6 PORTE COCHERE SECTIONS
S4.7 PORTE COCHERE SECTIONS
S4.8 PORTE COCHERE SECTIONS

PLUMBING

P0.1 PLUMBING ABBREVIATIONS AND SYMBOLS LIST
P0.2 PLUMBING SPECIFICATIONS
P0.3 PLUMBING SCHEDULES
P0.5 PLUMBING DIAGRAMS
P0.6 GAS ISOMETRIC DIAGRAM
P1.0 PLUMBING OVERALL FLOOR PLAN
P1.1 PLUMBING ENLARGED FLOOR PLAN - GAMING
P1.01 PLUMBING SITE PLAN
P1.2 PLUMBING ENLARGED FLOOR PLAN - SOUTH
P1.3 PLUMBING ENLARGED FLOOR PLAN - BOH
P1.4 PLUMBING ENLARGED FLOOR PLAN - BANQUET BOH
P1.5 PLUMBING ENLARGED FLOOR PLAN - NORTH
P1.6 PLUMBING ENLARGED PLANS - WATER & GAS
P1.7 PLUMBING ENLARGED PLANS - WATER & GAS
P1.8 PLUMBING ENLARGED PLANS - DW & V
P1.9 PLUMBING ENLARGED PLANS - DW & V
P6.1 PLUMBING ROOF PLAN
PFS.101 PLUMBING FOOD SERVICE WASTE & VENT PLAN - CASINO BAR & EDR
PFS.102 PLUMBING FOOD SERVICE WASTE & VENT PLAN - GRAB-N-GO KITCHEN
PFS.103 PLUMBING FOOD SERVICE WASTE & VENT PLAN - BANQUET KITCHEN
PFS.104 PLUMBING FOOD SERVICE WASTE & VENT PLAN - WAREHOUSE
PFS.105 PLUMBING FOOD SERVICE WASTE & VENT PLAN - FINE DINING
PFS.106 PLUMBING FOOD SERVICE WATER & GAS PLAN - CASINO BAR & EDR
PFS.107 PLUMBING FOOD SERVICE WATER & GAS PLAN - GRAB-N-GO KITCHEN
PFS.108 PLUMBING FOOD SERVICE WATER & GAS PLAN - BANQUET KITCHEN
PFS.109 PLUMBING FOOD SERVICE WATER & GAS PLAN - WAREHOUSE
PFS.110 PLUMBING FOOD SERVICE WATER & GAS PLAN - FINE DINING

MECHANICAL

M0.1 MECHANICAL ABBREVIATIONS AND SYMBOLS LIST
M0.2 MECHANICAL SPECIFICATIONS
M0.3 MECHANICAL SCHEDULES
M0.4 MECHANICAL SCHEDULES
M0.5 MECHANICAL SCHEDULES
M0.6 MECHANICAL SCHEDULES
M0.7 MECHANICAL SCHEDULES
M0.8 MECHANICAL DIAGRAMS
M0.9 MECHANICAL DIAGRAMS
M0.10 MECHANICAL CONTROLS DIAGRAMS
M0.11 MECHANICAL CONTROLS SEQUENCES
M0.12 MECHANICAL CONTROLS POINTS
M0.13 MECHANICAL PIPING DIAGRAMS
M1.0 MECHANICAL OVERALL FLOOR PLAN
M1.1 MECHANICAL ENLARGED FLOOR PLAN - GAMING
M1.2 MECHANICAL ENLARGED FLOOR PLAN - SOUTH
M1.3 MECHANICAL ENLARGED FLOOR PLAN - BOH
M1.4 MECHANICAL ENLARGED FLOOR PLAN - BANQUET BOH
M1.5 MECHANICAL ENLARGED FLOOR PLAN - NORTH

M4.1 MECHANICAL PIPING ENLARGED FLOOR PLAN - GAMING
M4.2 MECHANICAL PIPING ENLARGED PLAN - SOUTH
M4.3 MECHANICAL PIPING ENLARGED PLAN - BOH
M4.4 MECHANICAL PIPING ENLARGED PLAN - BANQUET BOH
M4.5 MECHANICAL PIPING ENLARGED PLAN - NORTH
M6.1 MECHANICAL ROOF PLAN

ELECTRICAL

E0.0 SYMBOL LIST
E0.1 GENERAL NOTES
E0.2 SINGLE LINE AND FOOD SERVICE SYSTEM NOTES
E0.3 SCHEDULES
E0.4 ELECTRICAL DIAGRAM
E0.10 SINGLE LINE DIAGRAM - MAIN SERVICE SWITCHBOARD 'TCMSA'
E0.11 PARTIAL SINGLE LINE DIAGRAM
E0.12 SINGLE LINE DIAGRAM - MAIN SERVICE SWITCHBOARD 'TCMSB'
E0.13 PARTIAL SINGLE LINE DIAGRAM
E0.14 PARTIAL SINGLE LINE DIAGRAM
E0.20 PANEL SCHEDULES
E0.21 PANEL SCHEDULES
E0.22 PANEL SCHEDULES
E0.23 PANEL SCHEDULES
E0.24 PANEL SCHEDULES
E0.25 PANEL SCHEDULES
E0.26 PANEL SCHEDULES
E0.30 DIMMER SCHEDULES
E0.40 LIGHTING FIXTURE SCHEDULE
ES1.0 ELECTRICAL SITE PLAN
ES1.0A ELECTRICAL SITE PLAN - CCTV INFRASTRUCTURE
E1.0 ELECTRICAL OVERVIEW PLAN
E1.1 ENLARGED POWER PLAN - GAMING
E1.1M ENLARGED MECHANICAL POWER PLAN - GAMING
E1.1A ENLARGED POWER PLAN - EAST
E1.1AM ENLARGED MECHANICAL POWER PLAN - EAST
E1.2 ENLARGED POWER PLAN - SOUTH
E1.2M ENLARGED MECHANICAL POWER PLAN - SOUTH
E1.3 ENLARGED POWER PLAN - BOH
E1.3M ENLARGED MECHANICAL POWER PLAN - BOH
E1.4 ENLARGED POWER PLAN - BANQUET BOH
E1.5 ENLARGED POWER PLAN - NORTH
E1.5M ENLARGED MECHANICAL POWER PLAN - NORTH
E1.6 POWER PLAN - ROOF
E3.1 ENLARGED ELECTRICAL ROOM PLAN
E3.2 ENLARGED ELECTRICAL ROOM PLANS
E3.3 ENLARGED PLANS
E6.1 ENLARGED LIGHTING PLAN - GAMING
E6.1A ENLARGED LIGHTING PLAN - EAST
E6.2 ENLARGED LIGHTING PLAN - SOUTH
E6.3 ENLARGED LIGHTING PLAN - BOH
E6.4 ENLARGED LIGHTING PLAN - BANQUET BOH
E6.5 ENLARGED LIGHTING PLAN - NORTH
E7.1 ENLARGED EXTERIOR LIGHTING PLAN
E7.2 ENLARGED EXTERIOR LIGHTING PLAN
E7.3 ENLARGED EXTERIOR LIGHTING PLAN
E7.5 ENLARGED EXTERIOR LIGHTING PLAN
E7.6 ENLARGED EXTERIOR LIGHTING PLAN
E7.7 ELECTRICAL ELEVATION WEST
E7.8 ELECTRICAL ELEVATIONS NORTH AND SOUTH

EFS120 FOODSERVICE ELECTRICAL CONNECTION PLAN
EFS121 FOODSERVICE ELECTRICAL CONNECTION PLAN
EFS122 FOODSERVICE ELECTRICAL CONNECTION PLAN
EFS123 FOODSERVICE ELECTRICAL CONNECTION PLAN
EFS124 FOODSERVICE ELECTRICAL CONNECTION PLAN

FOODSERVICE

FS101 FOODSERVICE EQUIPMENT ARRANGEMENT PLAN
FS102 FOODSERVICE EQUIPMENT ARRANGEMENT PLAN
FS103 FOODSERVICE EQUIPMENT ARRANGEMENT PLAN
FS104 FOODSERVICE EQUIPMENT ARRANGEMENT PLAN
FS105 FOODSERVICE EQUIPMENT ARRANGEMENT PLAN
FS106 FOODSERVICE EQUIPMENT SPECIAL CONDITIONS PLAN
FS107 FOODSERVICE EQUIPMENT SPECIAL CONDITIONS PLAN
FS108 FOODSERVICE EQUIPMENT SPECIAL CONDITIONS PLAN
FS109 FOODSERVICE EQUIPMENT SPECIAL CONDITIONS PLAN
FS110 FOODSERVICE EQUIPMENT SPECIAL CONDITIONS PLAN
FS111 FOODSERVICE EQUIPMENT PLUMBING CONNECTION PLAN
FS112 FOODSERVICE EQUIPMENT PLUMBING CONNECTION PLAN
FS113 FOODSERVICE EQUIPMENT PLUMBING CONNECTION PLAN
FS114 FOODSERVICE EQUIPMENT PLUMBING CONNECTION PLAN
FS115 FOODSERVICE EQUIPMENT PLUMBING CONNECTION PLAN
FS116 FOODSERVICE EQUIPMENT PLUMBING & MECHANICAL CONNECTION SCHEDULE
FS117 FOODSERVICE EQUIPMENT MECHANICAL CONNECTION PLAN
FS118 FOODSERVICE EQUIPMENT MECHANICAL CONNECTION PLAN
FS119 FOODSERVICE EQUIPMENT MECHANICAL CONNECTION PLAN
FS120 FOODSERVICE EQUIPMENT ELECTRICAL CONNECTION PLAN
FS121 FOODSERVICE EQUIPMENT ELECTRICAL CONNECTION PLAN
FS122 FOODSERVICE EQUIPMENT ELECTRICAL CONNECTION PLAN
FS123 FOODSERVICE EQUIPMENT ELECTRICAL CONNECTION PLAN
FS124 FOODSERVICE EQUIPMENT ELECTRICAL CONNECTION PLAN
FS125 FOODSERVICE EQUIPMENT ELECTRICAL CONNECTION SCHEDULE
FS126 FOODSERVICE EQUIPMENT BEVERAGE LINE RUN PLAN
FS127 FOODSERVICE EQUIPMENT VENTILATION PLAN
FS128 FOODSERVICE EQUIPMENT VENTILATION PLAN
FS129 FOODSERVICE EQUIPMENT VENTILATION PLAN
FS130 FOODSERVICE EQUIPMENT VENTILATION PLAN
FS131 FOODSERVICE EQUIPMENT VENTILATION PLAN
FS132 FOODSERVICE EQUIPMENT VENTILATION PLAN
FS133 FOODSERVICE EQUIPMENT VENTILATION PLAN
FS134 FOODSERVICE EQUIPMENT VENTILATION PLAN
FS135 FOODSERVICE EQUIPMENT VENTILATION PLAN
FS136 FOODSERVICE EQUIPMENT VENTILATION PLAN
FS137 FOODSERVICE EQUIPMENT VENTILATION PLAN
FS138 FOODSERVICE EQUIPMENT VENTILATION PLAN
FS139 FOODSERVICE EQUIPMENT VENTILATION PLAN
FS140 FOODSERVICE EQUIPMENT VENTILATION PLAN
FS141 FOODSERVICE EQUIPMENT VENTILATION PLAN
FS142 FOODSERVICE EQUIPMENT VENTILATION PLAN
FS143 FOODSERVICE EQUIPMENT VENTILATION PLAN
FS201 FOODSERVICE EQUIPMENT ELEVATIONS
FS501 FOODSERVICE EQUIPMENT DETAILS
FS502 FOODSERVICE EQUIPMENT DETAILS
FS503 FOODSERVICE EQUIPMENT DETAILS
FS504 FOODSERVICE EQUIPMENT DETAILS
FS505 FOODSERVICE EQUIPMENT DETAILS
FS506 FOODSERVICE EQUIPMENT DETAILS
FS507 FOODSERVICE EQUIPMENT DETAILS

FS508 FOODSERVICE EQUIPMENT DETAILS
FS509 FOODSERVICE EQUIPMENT DETAILS
FS510 FOODSERVICE EQUIPMENT DETAILS

FIRE ALARM

ITS000A SYMBOLS LEGEND AND DRAWING INDEX
ITS000B GENERAL NOTES, SPECIFICATIONS, AND SCHEDULES
ITS001 SECURITY PLAN DIAGRAMS
ITS002 SECURITY PLAN DIAGRAMS
ITS100 SECURITY SITE PLAN
ITS101 SECURITY PLAN - AREA 1
ITS102 SECURITY PLAN - AREA 2
ITS103 SECURITY PLAN - AREA 3
ITS104 SECURITY PLAN - AREA 4
ITS105 SECURITY PLAN - AREA 5
ITS200 DATA PLANS & DIAGRAMS - RELEASED BY ADDENDUM
ITAV100 AV PLANS & DIAGRAMS - RELEASED BY ADDENDUM

EXHIBIT E
SPECIAL CONDITIONS
CNE TAHLEQUAH CASINO

March 29, 2018

Article 1: CONTRACT DOCUMENTS

1.1 THE CONTRACT DOCUMENTS

1.1.2 – The contract between the Owner and Manhattan, as well as other contract documents applicable and not included herein, are available for review at Manhattan’s main office at **5601 South 122nd East Ave., Tulsa, Oklahoma 74146.**

Article 2: SUBCONTRACTOR

2.2 TIME OF PERFORMANCE

2.2.7 – Subcontractor includes all return (comeback) work as well as remobilization efforts relating to this subcontract which is to be required or should be anticipated in order to carry out the work of this subcontract as intended.

2.2.7.1 – To assist in developing the Project Schedule, each Subcontractor will submit a schedule that illustrates the key components of their work and how it supports the Project Schedule within 10 days of award. Manhattan shall develop the Project Schedule and as such, durations may be altered to meet the overall completion for all trades.

2.2.7.2 –Subcontractor shall confirm approved dates of delivery to Manhattan 30 days prior to delivery. Subcontractor shall accept delivery on the established dates or be responsible for any damage resulting from his failure to take delivery of the shipment on the established dates. Promptly upon delivery, the Subcontractor, shall inspect the materials or equipment for possible shortage or damage. If shortage or Damage has been identified, subcontractor shall notify Manhattan of its plan to replace or supplement any items deemed unusable.

2.2.7.3 – Each Subcontractor as appropriate, will meet with Manhattan and the Project Scheduler throughout the duration of the project to coordinate and develop their portion of the Detailed Overall Project Schedule.

2.2.7.4 – Subcontractor shall anticipate that both overtime and weekend work as well as the normally anticipated weather impacts are to be expected. Subcontractor agrees to provide man power and equipment as required by the Project Schedule, including interim milestone dates, along with any overtime work required to meet the schedule should Subcontractor fall behind due to their own lack of performance and/ or as a result of inclement weather.

2.2.7.5 – Subcontractor agrees to complete any punch-list items for the work with-in fifteen (15) days of issuance.

2.2.7.6 - Normal project working hours will be seven (7) Days a week 7:00 AM to 5:00 PM at a minumin and as required to maintain project schedule. This will be a fast track project. Any

required overtime shall be included in your bid. Whenever a Subcontractor desires to work at other than normal work hours he shall notify Manhattan in writing at least forty-eight (48) hours in advance. It is only with Manhattan prior approval that work may be conducted at other than normal work hours. Failure of the Subcontractor to give such timely notice may be cause for Manhattan to require the removal or uncovering of the work performed during such time without the knowledge of Manhattan and the replacement thereof. Special arrangements can be made for emergency work or shutdowns as may be required.

2.4 SUBCONTRACTOR'S LIABILITY

2.4.7 – LIQUIDATED DAMAGES - Subcontractor acknowledges and agrees that delays in completing this project could result in the assessment of Liquidated Damages or Other Damages against Manhattan in accordance with the Agreement between Manhattan and the Owner. If said damages are enacted upon Manhattan due to subcontractor failure, a proportionate share shall be enacted upon subcontractor, of which, proportionate value shall be at the sole discretion of Manhattan Construction.

2.9 CLEANUP

2.9.1 – Manhattan will provide dumpsters located on the project site for the disposing of construction debris. Each Subcontractor shall agree to comply with the Project Policy and Procedure for daily job clean up.

2.9.2 – Each Subcontractor shall adhere to the requirements and procedures for compliance with the Manhattan standard policy for clean up, which may include waste separation and recycling. Dumpsters, appropriate for each type of debris, will be provided by Manhattan. Each Subcontractor will be responsible for properly sorting and disposing of all their debris into the appropriate dumpsters. Failure to comply will result in costs to the Subcontractor.

2.9.3 – All large or bulky waste items shall be broken down as to limit the filling of waste containers prematurely. Subcontractor shall provide all labor or equipment to crush, dismantle or otherwise breakdown such waste prior to depositing into dumpsters.

2.9.4 – Specific types and classifications of construction debris are not allowed to be deposited in the job site dumpsters and therefore are the Subcontractor's responsibility to remove from the job site and dispose of legally. These items include but are not limited to: 1) materials unsuitable for disposal by standard commercial procedures; 2) materials classified as environmentally hazardous or environmental contaminants; 3) highly volatile or explosive substances; 4) waste concrete; 5) residential garbage or trash from outside the project; 6) any material traditionally not accepted by landfills in the metropolitan area or being recycled through the jobsite recycling program.

2.9.5 – Each Subcontractor is responsible to leave his Work in a clean condition. This includes, but is not limited to, removal of all grease, dust, dirt, stains, labels, fingerprints, mud and other foreign matter. All Subcontractors will be responsible for control of dust generated by their operation.

2.9.6 – GENERAL CLEAN UP COMPOSITE CREW – If determined solely by Manhattan, the site is not cleanly and well kept, in addition to its responsibility for specific clean-up of its debris, each Subcontractor, while on-site, is required to participate in a composite Project clean-up crew, for the purpose of general clean up and removal of "indefinable" debris. Each Subcontractor agrees to provide capable laborer(s), equipped with a broom, shovel, and a 1 cubic yard capacity trash buggy to participate in the composite clean-up crew as scheduled and directed by Manhattan. Each Subcontractor shall contribute labor to the composite crew at the following ratio:

A. Twelve (12) man hours per week for five (5) to fifteen (15) on-site employees.

B. Twenty-Four (24) man hours per week for sixteen (16) to thirty (30) on-site employees.

For example: 5-15 employees require a total of 12 composite crew laborer hours per week; 16-30 employees require a total of 24 composite crew laborer hours per week. Trash and debris from the composite cleaning operation will be deposited in the jobsite dumpsters provided by Manhattan. The composite clean-up crew will meet each scheduled day during the course of the project at a time and place as determined by a Manhattan designated representative.

2.9.7 – Manhattan may, at its discretion, limit the areas where employees can eat/drink inside the building. Tobacco products are strictly forbidden inside the building.

2.9.8 – The Owner's facilities and property are not to be used by any Subcontractor for the disposal of their trash or debris. Owner facilities will not be used for eating or use of any tobacco products.

2.9.9 – Trash chutes may not be installed without the prior approval of Manhattan Construction Company.

2.9.10 – In accordance with (obtaining the LEED accreditation) (the "Municipality" Green Building Program), airborne particulates must be kept to a minimum. Therefore, after conditioned air is provided inside the building, HEPPA filters (or an approved equal) shall be used with any vacuums. Sweeping of dirt and debris will not be allowed without use of "Clean Sweep" or product used to limit airborne dust particles.

2.12 APPROVALS

2.12.2.1 – Subcontractors must expedite and follow up on all submittals and re-submittals to insure earliest possible review or approval. Field use drawings shall be issued promptly and in sufficient quantity by the Subcontractor immediately after the return of accepted documents. Time extensions will not be allowed for submissions that do not allow enough time for reasonable review, comment, and return. Time extensions will not be allowed for re-submittals that did not meet the original Contract Document requirements.

Any substitutions are to be processed in the first 90 days of the project.

2.12.2.2 – DESIGN DRAWINGS - If, as a part of this Contract, Subcontractor is required to produce design drawings, such drawings shall bear the signature and seal of an engineer, licensed to practice in the State of **Oklahoma**. Any subsequent review of such design by Manhattan, Owner or Architect shall be for purposes of compliance with the Project Requirements only and shall not relieve the Subcontractor and its engineer from total responsibility for its design.

Article 3: CLAIMS AND DISPUTES

3.5 SETTLEMENT OF DISPUTES

3.5.7 – AUDITS - For all work authorized by Manhattan or Owner to be performed by Subcontractor, or its Sub-subcontractors; Subcontractor's and Sub-subcontractor's records relating to such work shall be open to audit, review, and copying by Manhattan.

3.5.8 – If Subcontractor, or any of its Sub- Subcontractor, submits or disputes an action or non-action by Manhattan or Owner, all records relating to such a claim or dispute shall be open to audit, review, and copying by Manhattan and Owner. If, subcontractor fails to substantiate their claim, all cost of Audit shall be borne by the Subcontractor.

Article 4: CHANGES IN THE WORK

4.1 CHANGES IN THE WORK

4.7 - Overhead and Fee percentages shall not exceed the rates as defined below and shall include, but not be limited to, insurances, bonds, use of small tools, incidental safety equipment, incidentals and/or office expenses, office equipment and off site personnel:

For Work performed by Subcontractor's own forces:

- Overhead & Profit - 10% on the first \$25,000
- 10% on the balance over \$25,000

For subcontracted Work:

- Overhead & Profit - 5% on the first \$25,000
- 5% on the balance over \$25,000

NOTES:

On changes involving both additions and deletions, percentages for overhead and profit will be allowed on the net difference between the adds/deducts.

4.7.1 Subcontractor, if performing work on an approved time and material basis, shall submit time and material records for signature of hour verification to MCC no later than 10:00 AM the day following work being performed. All records must be signed and dated by proper MCC representative. Records must be complete with proper description of work and must reference any RFI's associated with the changes. If work is not submitted and approved by proper MCC personnel, that portion of any T&M request will be deleted and not approved for any reimbursement.

4.7.2 Subcontractor, if performing work per MCC work authorization(s), shall submit all pricing recaps within a reasonable time but no more than 15 days following completion of authorized work.

Article 5: PAYMENTS

5.1 SCHEDULE OF VALUES

5.1.3 – The Schedule of Values will be submitted in a format as prescribed by, and to the level of detail specified by, Manhattan, Owner and Architect. The Schedule of Values may be modified from time to time if required by Manhattan, Owner or Architect.

5.1.4 – The Schedule of Values shall include value/s for submittals, punch-list, warranty, attic stock, closeout documents & products and required mock-ups as independent line items for this scope of work. All warranties, O&M Manuals, Attic Stock and other Close-Out related items shall be submitted for review no later than Subcontractors billings achieving 75%.

5.2 APPLICATION FOR PAYMENT

5.2.9 - Subcontractor shall sign project specific lien waiver forms as required by Manhattan and/or Owner in order to receive both interim and final payment.

5.2.10 – APPLICATION FOR PAYMENT - Subcontractor shall submit an Application for Payment by the 20th of each month, including all applicable backup for materials stored offsite (if allowed), and project cost to 20th off the month.

5.2.11 – If Owner, Architect and Manhattan agree, the Subcontractor may bill for stored materials, the following conditions must be met:

5.2.11.1 – Bill of Sale issued identifying the material as the property of the Owner.

5.2.11.2 – Evidence submitted that all materials are insured and bonded for loss of any kind either at the stored location, in transit, or on-site.

5.2.11.3 – A certificate of insurance with a loss damage clause naming Manhattan and Owner as additional insured.

5.2.11.4 – Subcontractor shall arrange and pay travel expenses for Owner, Architect and Manhattan to inspect material, if requested.

5.2.11.5 – Submit photographic evidence of the stored materials.

Article 6: PROTECTION OF PERSONS AND PROPERTY

6.1 SAFETY OF PERSONS AND PROPERTY

6.1.1 – Any Subcontractor with 25 or more employees (including Sub-subcontractors) on-site performing work shall be required to employ a full time, on-site, sole duty safety manager who shall be responsible for the overall safety compliance of the Subcontractors (and sub-subcontractors) employees. In the event that a Subcontractor exceeds 100 employees on a project, a 2nd, full time, sole duty safety manager shall be incorporated into the project at the expense of the Subcontractor.

6.1.2 – If required by Manhattan or the Owner, all employees working on the project must pass a background check inclusive of proper drug screening. If on site, site specific drug testing is not required, Subcontractor shall supply drug screen verification of all employees indicating a passed drug screen within 30 days of that employee commencing work on the project site. All cost of background check and drug screening shall be borne by the Subcontractor.

6.1.3 - Subcontractor shall provide Manhattan with safety data including but not limited to man hours worked, LTIs, and citations for the project on a monthly basis or more often as Manhattan may request. Near miss incidents shall be reported within 24 hours of occurrence.

Article 11: LAWS, REGULATIONS AND ORDINANCES

11.1 In regard to Article 11 of Manhattan's General Provisions: SUBCONTRACTOR IS TO COMPLY WITH ALL CHEROKEE NATION, TRIBAL EMPLOYMENT RIGHTS OFFICE (TERO), NATIONAL INDIAN GAMING ASSOCIATION (NIGA), AND ALL BUREAU OF INDIAN AFFAIR'S (BIA) RULES, REGULATIONS, AND LICENSING REQUIREMENTS INCLUDING ALL FEES AND ASSESSMENTS, ASSESSMENT, APPLICABLE TO THIS PROJECT.

11.1.1 - TERO document "An Act" Legislative Act 01-14 dated February 10, 2014. This Document is ACT AMENDING LA 30-12, "CHEROKEE NATION EMPLOYMENT RIGHTS ACT"

11.1.2 - Subcontractors are to EXCLUDE the cost for Section; Title 40, § 1011; T. To assess an Employee Rights Fee of one-half (1/2) of one percent (1%) on all covered contracts. This cost will be paid by the Construction Manager.

11.1.3 - The Work Permits paragraph of the Tribal Employment Rights Office (TERO) Project Labor Agreement - Master Agreement LA 01-14 states: No person who is not a member of a federally recognized tribe shall be employed by a covered employer until he or she has obtained a work permit from the TERO at a cost of twenty-five dollars (\$25) per day, per permit. Subcontractors are to INCLUDE in their proposed price for the work, all costs associated with the twenty-five (\$25) per day work permit for every non-Indian individual employed on this project.

Article 13: ADDITIONAL TERMS AND CONDITIONS

13.1 LAYOUT AND ENGINEERING

13.1.1 – LAYOUT OF WORK - Each Subcontractor shall lay out his own work. Each Subcontractor shall make provisions to preserve any control points established by others, such as monuments, stakes, bench marks or other datum points and shall replace at his cost any of these which might be lost or destroyed through his neglect.

13.1.1.2 – Each Subcontractor shall be responsible for the correct location, dimensions and elevations of his work. As the work progresses, the Subcontractor shall lay out the exact locations of work under his contract. Subcontractors shall coordinate the locations and layout of their work with the other Subcontractors.

13.1.1.3 – All Work shall be neatly and carefully laid out to provide the most useful space utilization and the most orderly appearance. Before proceeding with any work where exposed to view or where conflict might occur, Subcontractor shall carefully plan the layout and review any questionable installations with Manhattan.

13.1.1.4 – Limits of Construction: are generally delineated in the Contract Documents. These limits shall not be construed as preventing the Subcontractor from performing work outside the Limits should the contracted scope of work require such performance.

13.1.3 - Subcontractor is responsible for all block-outs, coring and sleeves as required to install Work in floor slabs ceilings and walls for accommodating their materials, piping or equipment.

13.1.4 - Manhattan may, at its discretion, choose to validate certain measurements throughout the project. This validation does not relieve the Subcontractor of the responsibility for its own layout.

13.1.5 – Terms and conditions on delivery tickets, back charge or extra work tickets, purchase orders, proposals, and similar shall not be binding on Manhattan if not incorporated by change order to the Subcontract.

13.2 USE OF TEMPORARY FACILITIES

13.2.1 – Designated Subcontractors might be allowed to have limited on-site construction trailers. Manhattan shall determine placement and scheduled duration based on site requirements. Each Subcontractor is responsible to provide his own field offices. Each Subcontractor shall arrange and pay for installation, use, and removal of all required utilities including but not limited to, temporary water, sewer, office telephone, internet, telephone for his sub-subcontractors and workers, and electrical hookup for his and his sub-subcontractors offices.

13.2.2 – Subcontractors shall maintain the designated area for offices and sheds in a clean and orderly manner. This includes removal of weeds, debris, trash and clean-up of the area until removal of their temporary structures. The area will then be restored to the same condition prior to the temporary structures.

13.2.3 – A limited number of on-site parking may be made available to workers and visitors in locations designated by Manhattan. A limited number of parking spaces may also be made available at the construction trailer compound for designated company vehicles properly identified. Any damages occurring to employee automobiles or vehicles shall be borne by the employee. The Owner, Engineer, and Manhattan shall not be liable for any theft or damages.

13.2.4 – TEMPORARY FENCING - The Subcontractor shall maintain, repair or replace fencing damaged as a result of their operation. Subcontractors shall remove and replace fencing and gates required to provide access for oversized items.

13.2.5 – TEMPORARY CONSTRUCTION ACCESS - Manhattan will provide at least one site construction access point.

13.2.5.1 – Each Subcontractor shall be responsible to repair any damage done to the site construction access resulting from his operations.

13.2.6 – TEMPORARY ELECTRICAL POWER AND LIGHTING – Manhattan, or designated others, will provide and maintain temporary power distribution, lighting, and service for the Project as follows:

13.2.6.1 Eight (8) 120 volt GFI receptacles on 200-foot centers throughout the building.

13.2.6.2 Temporary lighting required for general construction that is consistent with OSHA standards. All other special lighting or power required for detailed and finish work shall be furnished by each Subcontractor.

13.2.6.3 Subcontractors will provide their own special power as follows.

Each Subcontractor requiring service of capacity or characteristics other than that provided by Manhattan must make arrangements with the Electrical Subcontractor and pay for their own installation, removal and service.

Each Subcontractor requiring service before temporary power is established will be responsible for providing power generators or supply service for the period of time needed before service is established.

Grounded Power Extension cords 12 gauge or heavier gauge, lamps, light stands and fuses from the distribution outlets to points of use shall be provided by each Subcontractor to meet their own requirements.

All Temporary equipment and wiring for power, lighting and distribution requirements shall be in accordance with applicable provisions of governing laws, codes and ordinances. Construction power at the sources shall be 120/208 volt single phase. Protection shall be provided for the power supply source companies with disconnect switch and other required devices.

All temporary wiring and distribution equipment shall be maintained so as not to constitute a hazard to persons or property.

Each Subcontractor is responsible to provide an assured grounding program in accordance with OSHA regulations for their electrical power requirements.

All Temporary electrical installations shall be in compliance with the contract and latest N.E.C. or OSHA requirements, whichever is more stringent. Manhattan shall arrange to pay for temporary power consumption for the building unless noted otherwise.

13.2.7 – SCAFFOLDING - Each Subcontractor is responsible for providing and maintaining any and all scaffolds and other staging as required to complete its work or as specified in Bid Package Scope of Work. All said scaffolds and staging equipment shall be maintained by each subcontractor in accordance with all applicable safety regulations. Scaffolding shall be a solid deck platform within ladder distance of lowest elevation point on the ceiling. All equipment/lifts required to provide access to ceiling area above scaffold deck shall be included within each Subcontractors quote. Prior to scaffold erection, all subcontractors shall include all hoisting and/or lifts required to perform their scope of work. All subcontractors shall coordinate all scaffold usage with Manhattan's field personnel and other subcontractors on the project.

13.2.8 – TEMPORARY STAIRS, LADDERS, RAMPS, RUNWAYS AND BARRICADES - Subcontractors shall provide all ladders, stairs, ramps, etc. required to perform their work.

13.2.8.1 – Prior to construction of the permanent exterior building perimeter wall, temporary perimeter safety railings shall be installed. Subcontractors shall coordinate the sequence of access of materials and all other operations involving the temporary removal and replacement of these safety railings with Manhattan and shall exercise due care to protect all safety railings and shall carry out all work in a manner to minimize the number of openings in safety railings. Each Subcontractor is responsible to protect any other openings installed by them or for their work. If necessary to install its work, Subcontractor will remove and immediately replace barricades. Each Subcontractor will provide any other barricades required as a consequence of its work in accordance with all local, state and federal regulations.

13.2.8.2 – DEWATERING - All pumping, bailing or well point equipment necessary to keep excavations, trenches, site utility lines, sewers, manholes, meter pits, pull boxes, etc. free from the accumulation of water during the entire excavating and backfilling progress of this work shall be the responsibility of the Subcontractor performing said excavations and trenches.

13.2.8.2.1 -MOLD PREVENTION - Subcontractor shall comply with all rules, regulations and procedures to ensure final construction is free from “Mold” or any residue which can cause future mold growth. Further and as applicable to the Work, continuous clean-up shall be required with no accumulation of waste materials or debris. The following additional cleaning procedures shall be performed. This is not “final cleanup”, but rather continual cleaning as the work is completed in order to ensure the work is clean at completion..

13.2.8.3 – Each Subcontractor shall dispose of water in such a manner as will not endanger public health or cause damage or expense to public or private property and abide by the requirements of any public agencies having jurisdiction including the provision to supply a settling tank before depositing into storm sewer. Each Subcontractor shall provide for temporary metering and payment of disposal fees if required.

13.2.10 – TEMPORARY CONSTRUCTION WATER SYSTEM – A source of potable water at the Project Site will be provided. Location shall be as determined by Manhattan. All equipment, hoses and devices required to transport water away from that designated location shall be the provided by the Subcontractor.

13.2.10.1 – Each Subcontractor, for its employees, will provide ice, cups, coolers and trash receptacles for its employees and labor to distribute drinking water.

13.3 INTERFACE AND COORDINATION

13.3.1 – Each Subcontractor shall be subject to such Project Rules and Regulations for the conduct of the work as Manhattan or Owner may establish including but not limited to working hours, shifts, weekend work, holidays, make-up days, vehicles allowed onsite, hoisting, parking, field offices, site utilization, employee conduct, security badges and other such requirements identified by Manhattan. All employees shall be properly and completely clothed while working. Bare torsos, legs and feet will not be allowed. Possession or consumption of alcoholic beverages or non-prescription drugs or firearms or noxious behavior on the site is strictly prohibited. Violators shall be disciplined per the Safety Program and Prohibitive Articles Policy. Subcontractors shall adhere to Manhattan Safety Program for this Project.

13.3.2 – Before starting work, each Subcontractor shall ascertain from Manhattan which entrances, routes or roadways shall be used for access to the work, and use only those designated for

movement of personnel, materials, and vehicles to and from the work. Close coordination will be required of each Subcontractor with Manhattan, other Subcontractors, the city and others having an interest in the Project to assure that work on the site, access to and from the site and the general conduct of operations is maintained in a safe and efficient manner, and that disruption and inconvenience to existing streets and property is minimized. Each Subcontractor is responsible to review the site and be familiar with all existing conditions within and around the Owner's property including local conditions and requirements.

13.3.4 – PROJECT MEETINGS - Manhattan shall schedule, chair, and administer regularly scheduled meetings throughout the progress of the work for the purpose of coordinating and expediting the work. Such meetings shall be held at the job site bringing together responsible representatives of Subcontractor for the purpose of planning, assessing progress and discussing problems of mutual concern. Each Subcontractor will designate a representative who is required to attend the meetings and shall be qualified and authorized to make company decisions and follow-thru with actions required from the meetings. The representative shall also have authority to commit manpower and financial resources for their respective companies. Manhattan, at its sole discretion, may require Subcontractor to replace its representative. Failure by Subcontractor to provide project management or authorized representative attendance will not relieve the Subcontractor of its responsibility to perform the Work or otherwise comply with instructions provided during these meetings.

13.3.5 - Subcontractor shall provide an onsite supervisor who will be responsible for compliance with laws, codes and ordinances, and work coordination for schedule, quality and compliance with the schedule and other trades as well as with Manhattan.

13.4 PROTECTION OF MATERIALS, TOOLS, EQUIPMENT

13.4.1 – All cutting and/or coring is to be submitted to Manhattan for review prior to work commencing. Subcontractor shall coordinate this work with other subcontractors so as not to impact the work of others. All cutting and/or coring of slabs, walls, or ceilings due to missed scope of work or remedial/repair work is to be coordinated with other subcontractors so as not to impact the work of others. All scanning and/or x-raying of the item being cut/cored shall be the responsibility of the Subcontractor, including all associated costs. Subcontractor is to notify and review with Manhattan prior to the work commencing.

13.4.2 – Each Subcontractor is responsible for patching of all holes and openings made for accommodating their materials, piping or equipment. Patching is to match adjacent surfaces in materials and finish. Where patches are in fire rated construction, patches must comply with all project requirements (fire ratings, sound ratings, thermal ratings, etc.). Each Subcontractor is to utilize only tradesmen skilled in the specific finish and material involved in making the patches. All patching is to be done in a neat and workmanlike manner to the satisfaction of Manhattan. Defective work shall be corrected at no cost to Owner and Manhattan.

13.4.3 – Although Manhattan, at its own discretion, may provide on-site security services or devices, Subcontractors are responsible for protecting their own on-site office, tools, materials, supplies, and completed work from damage or theft until acceptance by the Owner.

13.4.4 – Subcontractors or any employees under their jurisdiction, shall be responsible for damages to the roofing, sheet metal, and/or roof structures while performing work on or above any roof

structure. The Roofing Subcontractor shall perform all repair work at the expense of the Subcontractor responsible for the damage.

13.5 TESTS AND INSPECTIONS

13.5.1 – Owner shall obtain and pay for an independent testing laboratory to provide Testing Services as defined in Specifications. Each Subcontractor will fully cooperate with Manhattan and the Owner's testing laboratory, and shall provide all certifications, test reports, mock-ups, samples and incidental labor, equipment and facilities required for the proper execution of this work.

13.5.2 – The Subcontractor shall be responsible for, and pay all costs associated with testing for approval of submittals, processing of substitution requests, or for the convenience of the Subcontractor.

13.5.3 – The Subcontractor shall be responsible for, and pay all costs associated with additional inspections, sampling, testing and re-testing as required when initial tests indicate work does not comply with the requirements of the Contract Documents.

13.5.4 – All other testing required by the Contract Documents, which is not provide by the Project testing laboratory, shall be borne by the Subcontractor if required to complete the work of this Subcontractor.

13.8 ELECTRONIC SYSTEMS AND COMMUNICATIONS

13.8.1 - Each Subcontractor is required to provide the resources necessary to access and work in Manhattan's Project Management Collaboration System (PMCS - Procore and/or similar) in order to communicate and work electronically with Manhattan and other members of the project. This includes but is not limited to maintaining an e-mail address, providing the software and hardware necessary for such communications (for both office and field personnel), and providing personnel familiar with electronic operations to maintain such communications. Subcontractor's supervisory field personnel shall be equipped with mobile devices (tablets, iPads, etc), in order to collaborate through the PMCS with Manhattan and other members of the project. The types of electronic documents and processes that may be utilized in the Project Management Collaboration System includes, but is not limited to, Bidding, Drawings, Specifications, RFI's, Submittals, Daily Reports, Scheduling, Inspections, Punchlist, Observations, RFP's, Change Event Pricing, Change Orders, Subcontract Agreement, Meeting Minutes, Letters, Notices, Bulletins, Requisitions, Pay Applications, etc.

Article 14: MISCELLANEOUS

14.8 HOISTING AND SPECIAL RIGGING

14.8.1 – With reference to Article 2.14 of MGP, and unless specifically stated otherwise, each Subcontractor is responsible to provide its own hoisting of personnel and materials. Subcontractor must submit a plan indicating its proposed equipment locations, including pick weight, safety factor, swing arcs, heights, staging areas, etc. and the proposed duration for use of the equipment. No such equipment may be structurally tied to the building without prior approval from proper project personnel or designers. All such equipment will be operated and maintained by trained operators in accordance with applicable safety regulations including OSHA, FAA, and Manhattan. Any required access roads for hoisting equipment are to be provided and maintained by Subcontractor. Each subcontractor is responsible for its own rigging equipment, spreaders, lifting device(es) as

well as any dunnage. Each subcontractor is responsible for the rigging, flagmen, radiomen, and other personnel needed for all hoisting.

14.8.2 – Subcontractor shall develop all erection and hoisting plans, schedules for joint utilization of hoisting equipment, pouring sequences and start times, etc.

14.8.3 – Material storage and material loading onto the slab-on-grade and elevated structural slabs will be coordinated with Manhattan's superintendent. No materials are to be moved on site or into the building without prior direct coordination with Manhattan's superintendent. Subcontractor shall provide loading information for both equipment and stored materials, which will be submitted to the structural engineer of record for review. Costs for structural repairs or remediation resulting from the failure to follow loading plans will be borne by the Subcontractor

14.8.4 – If Subcontractor elects to utilize Manhattan's hoisting facilities on an overtime or after-hours basis, Subcontractor will pay all wages and benefits of the crane or hoist operator, as determined by Manhattan

14.9 DELIVERIES

14.9.1 - All deliveries are to be coordinated through Manhattan's Field personnel or designated representative, a minimum of seventy-two (72) hours in advance. If required by Manhattan, deliveries will be scheduled at designated hours that may be other than normal working hours, at no additional expense to Manhattan or Owner. No material shall be stored on site without prior approval of Manhattan Construction field personnel. Manhattan shall not sign for any deliveries on the behalf of any subcontractor or sub-tier, nor shall Manhattan be responsible for any fees and/or penalties for rescheduled deliveries.

14.10 PRINTING

14.10 – All documents required by Subcontractor shall be ordered by Subcontractor at Subcontractor's expense.

14.12 QUALITY CONTROL

14.12.1 - Subcontractor will cooperate and comply with Manhattan's Quality Control Program. This program is solely for the benefit of Manhattan and shall not be construed to replace any Subcontractors Quality and Commissioning plan.

EXHIBIT "G"
Tax Exempt / Owner Direct Paid Invoice (ODPI) Payment Process

1. Identify supplier/vendors eligible for tax exemption process. Eligible supplier/vendors are providers of materials to the construction of CNE Tahlequah Casino and who remit taxes to OTC.
2. Provide list of supplier/vendors to Manhattan by executing Change Notice to the Contract between Manhattan.
3. CNE Tahlequah Casino to issue Tax Exemption Letter to each vendor. Letter to indicate contractual relation between CNE Tahlequah Casino, Manhattan, & Vendors.
 - Tax Exempt Entity – CNE Tahlequah Casino
 - Contractor (Tier 1) – Manhattan Construction Company
 - Contractor (Tier 2) – Subcontractors of Manhattan
 - Contractor (Tier 3) - All suppliers/vendors providing materials
4. Purchase Orders for materials shall clearly state that the purchase is being on behalf of the CNE Tahlequah Casino and that the material is necessary for the construction of the CNE Tahlequah Casino.
5. Subcontractor's Schedule of Values (G703) shall clearly identify all Invoices submitted as Tax Exempt, under column titled Owner Paid Materials.
6. Subcontractor shall include the supplier's/vendors W9 with the pay application.
7. Tax Exempt Invoice will be submitted monthly to Manhattan Construction Company. All invoices shall be listed on Tax Exemption Summary Sheet, to be submitted with each pay application (Format attached).
8. Manhattan shall submit monthly pay application for review and approval to the Design Professional. Approved pay application will be forwarded to CNE Tahlequah Casino for payment.
9. CNE Tahlequah Casino to issue checks made out to the supplier / vendor for all ODPI invoices. Checks will be delivered to Manhattan for distribution. Manhattan will distribute payments and collect Lien Waivers.

INVOICE

NOTE: To be in Compliance with Cherokee Nation ODPI Process, subcontractor's name shall NOT appear on the invoices.

SUPPLIER abc

INVOICE # 12282016
 DATE: JANUARY 4, 2017

[Street Address], [City, ST ZIP Code]
 Phone [000.000.0000] Fax [000.000.0000]
 [e-mail]

TO Cherokee Nation Entertainment, LLC
 777 West Cherokee Street
 Catoosa, OK 74015
 Attn: Corporate Construction Dept

SHIP TO Cherokee Nation Entertainment, LLC
 777 West Cherokee Street
 Catoosa, OK 74015
 Attn: Corporate Construction Dept

DO NOT USE IN CARE OF (C/O) - THE SUBCONTRACTOR - INVOICES WILL BE REJECTED

SALESPERSON	JOB	SHIPPING METHOD	SHIPPING TERMS	DELIVERY DATE	PAYMENT TERMS	DUE DATE
				11/15/16	Net 30	

QTY	ITEM #	DESCRIPTION	UNIT PRICE	DISCOUNT	LINE TOTAL
500	1235	(A) widgets	490	1%	245000
350	5432	(B) Widgets	510	1%	178500

		SUBTOTAL	419,265
		SALES TAX	0
		TOTAL	419,265

Make all checks payable to [Your Company Name]
THANK YOU FOR YOUR BUSINESS!

Request for Taxpayer Identification Number and Certification

**Give Form to the
requester. Do not
send to the IRS.**

Print or type See Specific Instructions on page 2.	Name (as shown on your income tax return)	
	Business name/disregarded entity name, if different from above	
	Check appropriate box for federal tax classification: <input type="checkbox"/> Individual/sole proprietor <input type="checkbox"/> C Corporation <input type="checkbox"/> S Corporation <input type="checkbox"/> Partnership <input type="checkbox"/> Trust/estate <input type="checkbox"/> Limited liability company. Enter the tax classification (C=C corporation, S=S corporation, P=partnership) ▶ _____ <input type="checkbox"/> Other (see instructions) ▶ _____	Exemptions (see instructions): Exempt payee code (if any) _____ Exemption from FATCA reporting code (if any) _____
	Address (number, street, and apt. or suite no.)	Requester's name and address (optional)
	City, state, and ZIP code	
List account number(s) here (optional)		

Part I Taxpayer Identification Number (TIN)

Enter your TIN in the appropriate box. The TIN provided must match the name given on the "Name" line to avoid backup withholding. For individuals, this is your social security number (SSN). However, for a resident alien, sole proprietor, or disregarded entity, see the Part I instructions on page 3. For other entities, it is your employer identification number (EIN). If you do not have a number, see *How to get a TIN* on page 3.

Social security number									

Note. If the account is in more than one name, see the chart on page 4 for guidelines on whose number to enter.

Employer identification number									

Part II Certification

Under penalties of perjury, I certify that:

1. The number shown on this form is my correct taxpayer identification number (or I am waiting for a number to be issued to me), and
2. I am not subject to backup withholding because: (a) I am exempt from backup withholding, or (b) I have not been notified by the Internal Revenue Service (IRS) that I am subject to backup withholding as a result of a failure to report all interest or dividends, or (c) the IRS has notified me that I am no longer subject to backup withholding, and
3. I am a U.S. citizen or other U.S. person (defined below), and
4. The FATCA code(s) entered on this form (if any) indicating that I am exempt from FATCA reporting is correct.

Certification instructions. You must cross out item 2 above if you have been notified by the IRS that you are currently subject to backup withholding because you have failed to report all interest and dividends on your tax return. For real estate transactions, item 2 does not apply. For mortgage interest paid, acquisition or abandonment of secured property, cancellation of debt, contributions to an individual retirement arrangement (IRA), and generally, payments other than interest and dividends, you are not required to sign the certification, but you must provide your correct TIN. See the instructions on page 3.

Sign Here	Signature of U.S. person ▶	Date ▶
------------------	----------------------------	--------

General Instructions

Section references are to the Internal Revenue Code unless otherwise noted.

Future developments. The IRS has created a page on IRS.gov for information about Form W-9, at www.irs.gov/w9. Information about any future developments affecting Form W-9 (such as legislation enacted after we release it) will be posted on that page.

Purpose of Form

A person who is required to file an information return with the IRS must obtain your correct taxpayer identification number (TIN) to report, for example, income paid to you, payments made to you in settlement of payment card and third party network transactions, real estate transactions, mortgage interest you paid, acquisition or abandonment of secured property, cancellation of debt, or contributions you made to an IRA.

Use Form W-9 only if you are a U.S. person (including a resident alien), to provide your correct TIN to the person requesting it (the requester) and, when applicable, to:

1. Certify that the TIN you are giving is correct (or you are waiting for a number to be issued),
2. Certify that you are not subject to backup withholding, or
3. Claim exemption from backup withholding if you are a U.S. exempt payee. If applicable, you are also certifying that as a U.S. person, your allocable share of any partnership income from a U.S. trade or business is not subject to the

withholding tax on foreign partners' share of effectively connected income, and

4. Certify that FATCA code(s) entered on this form (if any) indicating that you are exempt from the FATCA reporting, is correct.

Note. If you are a U.S. person and a requester gives you a form other than Form W-9 to request your TIN, you must use the requester's form if it is substantially similar to this Form W-9.

Definition of a U.S. person. For federal tax purposes, you are considered a U.S. person if you are:

- An individual who is a U.S. citizen or U.S. resident alien,
- A partnership, corporation, company, or association created or organized in the United States or under the laws of the United States,
- An estate (other than a foreign estate), or
- A domestic trust (as defined in Regulations section 301.7701-7).

Special rules for partnerships. Partnerships that conduct a trade or business in the United States are generally required to pay a withholding tax under section 1446 on any foreign partners' share of effectively connected taxable income from such business. Further, in certain cases where a Form W-9 has not been received, the rules under section 1446 require a partnership to presume that a partner is a foreign person, and pay the section 1446 withholding tax. Therefore, if you are a U.S. person that is a partner in a partnership conducting a trade or business in the United States, provide Form W-9 to the partnership to establish your U.S. status and avoid section 1446 withholding on your share of partnership income.



OKLAHOMA TAX COMMISSION

TAX POLICY AND RESEARCH DIVISION
TONY MASTIN, DIRECTOR

PHONE (405) 521-3133
FACSIMILE (405) 522-0063

December 29, 2003

Re: Our File Number LR 03-251; Exemption status of Indian Nations

In reply to the applicability of sales tax to Indian tribes, the Commission recognizes an exemption from sales tax under the circumstances outlined by the court in *Chickasaw Nation v. Oklahoma Tax Commission*, 31 F.3d 964, 973 (10th Cir. 1994). To be exempt, the sale must satisfy the following requirements:

1. The sale must be made directly to the federally recognized Indian tribe.
2. Payment must be received directly from the tribe.
3. The tribe must be the consumer or user of the purchased good which is consumed or used within Indian country.

While tribes, tribal enterprises and tribal members are immune from state taxation within "Indian country", this rule does not operate outside Indian Country, *Oklahoma Tax Commission v. Chickasaw Nation*, 115 S. Ct. 2214, 2223 (1995). To be exempt, the sale must satisfy the following:

1. The sale must be made directly to a tribal member or tribal enterprise.
2. Payment must be received directly from the tribal member or tribal enterprise.
3. The sale must occur on Indian country as evidenced by delivery ticket or shipping document.

Therefore, instead of a determination as to whether tribes or tribal enterprises are exempt from sales tax when purchasing resale items for the various types of businesses listed in your correspondence, there must be a determination that the sale meets the above-stated requirements as set out in the case of *Oklahoma Tax Commission v. Chickasaw Nation*, cited hereinabove.

This response applies only to the circumstances set out in your request of November 7, 2003. Pursuant to Commission Rule 710:1-3-73(e), this Letter Ruling may be generally relied upon **only** by the entity to whom it is issued, assuming that all pertinent facts have been

accurately and completely stated, and that there has been no change in applicable law. If I can be of further assistance, please feel free to contact me.

Sincerely,

A handwritten signature in cursive script that reads "Brenda J. Sullivan".

Brenda J. Sullivan
Tax Policy Analyst

EXHIBIT “H”

“Foreman Manhattan Construction Team Additional Safety Requirements”

**CHEROKEE NATION ENTERTAINMENT
TAHLEQUAH CASINO**

Project #3882

All Suppliers, their employees and all tiered suppliers when on site shall adhere and comply with all OSHA, Owner's and Foreman Manhattan's Project Safety requirements. This includes adherence to the following additional summary of Safety Rules which may exceed OSHA requirements:

Personal Protective Equipment

- OSHA approved eye protection (meeting ANSI Z87.1 standards) including side shields on eyeglasses are required to be worn by Subcontractor's employees including tiered subcontractors and suppliers while on the project site, except for personnel enclosed within a motor vehicle or within a temporary office.
- Hardhats and hard soled shoes or boots shall be worn at all times.
- Radios for entertainment including MP3 players and I-pods are not allowed on the jobsite.
- Texting, emailing, or other cell phone use is prohibited while operating any equipment.

Fall Protection

- All workers shall be protected by 100% fall protection above six (6) feet.
- When working on all ladders, employees shall be tied-off 100% of the time when working closer than one and one-half (1-1/2) times the ladder height to an opening or the edge of the building.
- Employees shall be tied off 100% of the time when working on straight ladders or when building scaffolds above six (6) feet.

Scaffolds

- Upon completion, scaffolds shall have and maintain a scaffold permit attached to the scaffold in full visibility of all employees at the access to the scaffold.
- Mobile scaffolds are not to be moved while a person and/or persons are on the scaffold. Additionally, scaffolds are not to be scooted (surf) by the person on scaffolding.

Crane Policy

- Load Moment Indicators must stop crane operations in the event of an impending overload and are required on all cranes as specified in OSHA 1926.1400. Scales, load cells, and audible warning devices are not acceptable LMI alternatives.
- Anti-2-block devices must stop crane operations in the event of an impending two-block and are required on all cranes as specified in OSHA 1926.1400. Scales, load cells, and audible warning devices are not acceptable anti-2block alternatives.
- Lift calculations are required for all lifts that are over 85% of the crane's capacity according to the crane manufacturer's load charts.
- Tower cranes, derricks, and lattice boom cranes shall be certified annually and prior to being put into service when they are initially erected and delivered to the jobsite, reconfigured, altered, climbed, or extensively repaired. Certifications are to be completed by a third party competent person, government, or private agency recognized by the U. S. Department of Labor to perform such inspections.

Safety Vests / Highly Visible Clothing

- As an addition to and in no way diminishing any government requirement, visibility safety vests or other equal shirts or jackets of MUTCD Class II, shall be worn at all times on Foreman Manhattan projects when the other basic PPE items of hard hats and safety glasses are required. Uniform highly visible shirts without reflective bands may be allowed when not required by regulations and meeting the minimum standards for the job set by the Foreman Manhattan superintendent.

BROKEN ARROW PUBLIC SCHOOLS

Freshman Academy – 2017 Additions and Renovations

Safety Training

- Subcontractor agrees to conduct a weekly safety training session for upcoming work activities or job conditions with his entire crew, and submit minutes with attendance noted of said meeting to Foreman Manhattan on a weekly basis.

SITE SPECIFIC PROJECT SAFETY PLAN AND HAZCOM PROGRAM

In addition to all other Safety requirements elsewhere identified, Subcontractor shall prepare, submit, and maintain a Project Safety Plan and HAZCOM Program (Global Harmonized System (GHS)) SPECIFIC TO THE PROJECT. A Site Specific Project Safety Plan and HAZCOM (GHS) Program must be in place prior to the commencement of any work activities. Upon award of the contract, Subcontractor shall complete said programs and submit to Foreman Manhattan for review. Project Safety Plans shall be customized to suit hazards associated with the given work. Upon initial acceptance, one copy of approved Site Specific Safety Plan and HAZCOM (GHS) Program will be held at a central location in Foreman Manhattan site office. Subcontractor is required to maintain Project Safety Plan and HAZCOM (GHS) Program over the duration of the project (e.g. GHS MDS (MSDS) sheets shall be inserted and Table of Contents updated in instances where new materials are introduced to the project).

FOREMAN | MANHATTAN
Construction Team

**PURCHASE
ORDER FORMS**

FOREMAN | MANHATTAN

Construction Team

FOREMAN MANHATTAN CONSTRUCTION TEAM

PURCHASE ORDER # _____.

JOB # _____.

Date: _____

Supplier: _____

Deliver to: _____

Attn: _____

Address: _____

Delivery Schedule: Per Contractor's Schedule

Telephone No: _____

MCC Cost Code: _____

Fax No: _____

Terms: _____

Email: _____

F.O.B: Jobsite

via: Trucks/Common Courier

1. When the words Manhattan or MCC are used in this Purchase Order they shall be referring to Foreman Manhattan Construction Team
2. **The materials and/or equipment to be furnished by Supplier are all _____ (Materials Only), including all items further identified in Exhibit "A- Scope of Work":**

Instructions:

1. Execute EACH COPY hereof and return them to Foreman Manhattan. No other form of acceptance is binding on Foreman Manhattan Construction Team.
2. The Purchase Order Number MUST appear on all correspondence, invoices, packing lists, bills of lading, and outside of package.
3. Render all invoices electronically to Foreman Manhattan Construction Team.
4. The listed Exhibit(s) attached hereto and incorporated herein by reference, are additional conditions of this Purchase Order.

Exhibit A (Scope of Work)	Pages 1 through <u>6</u>
Exhibit B (Supply Bond Form)	Page <u>1</u>
Exhibit C (Insurance Requirements/Sample)	Pages 1 through <u>3</u>
Exhibit D (Contract Documents)	Pages 1 through <u>6</u>
Exhibit E (Special Conditions of Purchase Order)	Pages 1 through <u>2</u>
Exhibit F (Project Schedule)	Pages 1 through <u>6</u>
Exhibit G (Tax Exempt)	Page <u>1</u>
Exhibit H (Foreman Manhattan Additional Safety Reqs)	Page <u>1</u>
Exhibit I (Indemnification)	Page <u>1</u>

Supply Bonds:

____ Supplier shall furnish a supply bond to Foreman Manhattan Construction Team on the form attached hereto and in the amount reflected thereon from a corporate surety company acceptable to Foreman Manhattan Construction Team.

____ The premium for said bond will be paid directly by Foreman Manhattan Construction Team as an addition to the price of this order.

____ The premium for the supply bond is included in the price of this order.

Supply bond not required.

Foreman Manhattan Construction Team agrees to pay Supplier for the material and/or equipment furnished under this Purchase Order the sum of, _____ DOLLARS (\$ _____), including sales tax.

Acceptance of this Purchase Order includes acceptance of and agreement to the terms and conditions on the following page, numbered paragraphs 1 through 20.

We acknowledge receipt of, and hereby accept,
Foreman Manhattan Construction Team Purchase Order:
"Supplier"

The Purchase Order is hereby approved:

"Foreman Manhattan"
FOREMAN MANHATTAN CONSTRUCTION TEAM

Signature

Signature

Printed Name

Larry Rooney

Printed Name

Title

Senior Vice President

Title

Date: _____

Date: _____

1. Contract Documents – All provisions of the Contract Documents (Listed in Exhibit A attached hereto) and Foreman Manhattan's agreement with the Owner (hereinafter the agreement and contract documents are both collectively and singularly referred to as the "Contract Documents") for the Project which relate to this Purchase Order ("Order") are incorporated herein by reference and made a part hereof. With respect to the materials, equipment and/or work covered by this Order and in the performance hereof, except as otherwise provided herein, Supplier shall assume all obligations, risks and responsibilities that Foreman Manhattan has assumed toward the Owner in the Contract Documents. The Contract Documents are available for inspection by the Supplier during normal working hours at Foreman Manhattan's office. In case of any dispute between Foreman Manhattan and Supplier, in any way relating to or arising from any act or omission of the Owner or involving the Contract Documents, Supplier agrees to be bound to Foreman Manhattan to the same extent that Foreman Manhattan is bound to the Owner by the terms of the Contract Documents.
2. Material and Workmanship; Warranty – Supplier shall furnish all warranties required by the Contract Documents and, without limiting the foregoing, expressly warrants that all materials, equipment and/or work covered by this Order will conform to the Contract Documents and that they will be merchantable, of good material and workmanship, free of defects, and fit and sufficient for the purposes for which they are ordered by Foreman Manhattan. Warranties required by the Contract Documents will begin to run from the date specified in the Contract Documents. Supplier acknowledges that its warranty also relates to future performance and that any limitations period, for commencement of any litigation or arbitration proceedings, shall accrue upon the date any defect is actually discovered in the materials, equipment and/or work furnished by Supplier. Supplier also agrees to replace upon demand, without charge, any materials and/or equipment that are found not to be as warranted and shall remedy any defects, latent or patent in nature, which may develop within the warranty and repose periods as set forth in the Contract Documents. The express warranties herein are in addition to, and not in substitution, for those warranties implied by law.
3. Time of Performance – Supplier shall furnish materials, equipment and/or work in accordance with the Delivery Schedule set forth in this Order or in the Contract Documents, and, in all events, in accordance with Foreman Manhattan's project schedule, including amendments, and any failure by Supplier to so furnish materials shall give Foreman Manhattan the right to cancel any undelivered balance of this Order without additional charge to Foreman Manhattan. **TIME IS OF THE ESSENCE** in the performance of this Order. Supplier shall give Foreman Manhattan 72 hours notice of all deliveries and said deliveries shall be made during working hours between 7:00 AM and 2:00 PM unless scheduled otherwise with Foreman Manhattan. Foreman Manhattan shall not be liable for any delay or impact damages to Supplier unless such delays result from active interference by Foreman Manhattan with the obligations of Supplier herein. Supplier shall be allowed an extension of time as the sole remedy for delays caused by reasons outside of its control to the extent allowed by the Contract Documents.
4. Liability and Indemnification – Except as provided below, Foreman Manhattan and Supplier waive claims against each other for consequential, incidental or special damages arising out of or relating to this Order. Supplier shall be liable to Foreman Manhattan for all costs Foreman Manhattan incurs or becomes responsible for as a result of Supplier's failure to comply with this Order. Supplier's liability shall include, but shall not be limited to, any acts or omissions of its lower-tier suppliers. Suppliers liability shall include, but not be limited to, (1) damages and other delay costs payable by Foreman Manhattan to Owner (including liquidated damages), (2) Foreman Manhattan's or any other subcontractors' increased costs of performance, such as extended overhead and increased performance costs, resulting from Suppliers' delays or failure to comply with the terms of this Order, (3) warranty and re-work costs, (4) liability to third parties, (5) consultant fees and (6) attorneys' fees and related costs. Supplier shall defend, indemnify and hold Foreman Manhattan, the Owner, and all parties noted to be indemnified by Foreman Manhattan's Contract with the Owner, and their agents and employees (the "Indemnified Parties"), harmless against and from, any and all claims and damages of every kind for injury or death of any persons (including employees of Supplier) and for damages to or loss of property of Foreman Manhattan, the Owner or any other person arising out of, or attributable directly or indirectly to, the performance by Supplier of this Purchase Order or any act or omission of Supplier, or its employees, agents, subcontractors or suppliers. **SUPPLIER IS LIABLE FOR DEFENSE AND INDEMNITY TO THE FULLEST EXTENT PERMITTED BY LAW AND THIS DEFENSE AND INDEMNIFICATION OBLIGATION APPLIES EVEN THOUGH THE MATTER IS A RESULT OF THE CONCURRENT NEGLIGENCE OF ANY OR ALL OF THE INDEMNIFIED PARTIES BUT SHALL NOT APPLY TO ANY INDIVIDUAL PARTY OF THE INDEMNIFIED PARTIES IF THE MATTER TO BE INDEMNIFIED IS THE RESULT OF THE SOLE NEGLIGENCE OF THAT INDIVIDUAL PARTY AND UNRELATED TO ANY NEGLIGENCE ON THE PART OF SUPPLIER.** This indemnity shall survive completion and/or termination of the Order.
5. Termination – Foreman Manhattan shall have the right to terminate all or any part of this Order for convenience by providing Supplier with a written notice of termination, which shall be effective upon receipt by Supplier, regardless of whether or not the Owner has terminated Foreman Manhattan. If this Order is terminated for convenience, Supplier shall be paid as its sole and exclusive remedy the amount representing costs which are due from the Owner for Supplier's materials, equipment and/or work, as provided in compliance with the Contract Documents, conditioned upon and after payment therefor by the Owner to Foreman Manhattan. If Supplier shall fail to perform any obligation under this Order, Foreman Manhattan, after having provided Supplier with written notice and an opportunity to cure its deficiencies within three (3) working days, may terminate Supplier's performance

of all or any part of this Order for default. In the event of such termination, Foreman Manhattan may, in addition to all other rights and remedies, which shall continue unabated, purchase substitute items or services elsewhere and hold Supplier liable for any excess costs incurred. Should it be determined that a termination for default was improper, such termination shall be deemed a termination for convenience and Supplier's sole and exclusive remedy shall be as provided in the case of a termination for convenience.

6. Inspection and Acceptance

a. Supplier shall provide appropriate facilities at all reasonable times for inspection by Foreman Manhattan, Architect, Owner, or their agents of the materials, equipment and/or work provided under this Order, whether at the Project site or at any place where such materials and/or equipment may be in preparation, manufacture, storage, or installation. Supplier shall promptly replace or correct any materials, equipment and/or work that Foreman Manhattan or Owner shall reject as failing to conform to the requirements of this Order, whether or not Foreman Manhattan and/or the Owner previously accepted the materials, equipment and/or the work. If Supplier does not so provide replacements or make corrections within the time set forth in the Contract Documents, or if a time is not set forth therein, within a reasonable time, Foreman Manhattan shall have the right to do so and Supplier shall be liable to Foreman Manhattan for any and all such excess costs. In those situations in which it may appear that correction or replacement of all or any part of projected work or materials would not be expedient, then Foreman Manhattan, at its option, and if allowed by the Contract Documents and Owner, may deduct from the payments due, or to become due, to Supplier such amount as in Foreman Manhattan's reasonable judgment will represent (i) the difference between the fair value of the rejected materials, equipment and/or work and the value thereof if it complied with this Order, or (ii) the cost of correction, whichever Foreman Manhattan determines is more appropriate and as allowed by the Contract Documents.

b. Supplier's remedy for wrongful rejection of materials, equipment and/or work pursuant to Section a. shall be limited to Foreman Manhattan's remedy under the Contract Documents if rejection is by the Owner or by Foreman Manhattan at request of the Owner. Foreman Manhattan shall be liable for Supplier's increased direct costs caused by wrongful rejection of materials, equipment and/or work if the Owner was not involved in the rejection.

c. The materials, equipment and/or work provided by Supplier shall be accepted according to the terms of the Contract Documents. Unless expressly agreed by Foreman Manhattan in writing, neither entrance and use by Owner or Foreman Manhattan nor payment to Supplier, shall constitute acceptance of materials, equipment and/or work. Acceptance of any part of this Order shall not bind Foreman Manhattan to accept future shipments.

d. Any quality control, inspection or quality assurance by Foreman Manhattan with respect to the materials, equipment and/or work provided by Supplier, shall not relieve the Supplier from responsibility for errors or deficiencies of any sort nor from the necessity of furnishing any materials, equipment and/or work required by the Contract Documents pursuant to this Order.

7. Delivery – Supplier shall insure and be responsible for the items provided hereunder until such time as they have been delivered and unloaded at the jobsite and accepted by Foreman Manhattan.

8. Liens – Supplier agrees to furnish, prior to any payments hereunder, evidence satisfactory to Foreman Manhattan, the Owner or both that payment has been made for all materials, equipment and/or labor used in filling this Order. If requested, Supplier shall furnish at the time of payment a bill of sale and a release of liens on Foreman Manhattan's standard form. In the event liens or claims of any kind are filed by anyone in relation to this Order, Supplier shall have the lien or claim discharged, within three (3) days of receipt of written notice, by posting a bond or other security, and if not so discharged, Foreman Manhattan may discharge the lien or claim and hold Supplier responsible for all costs in connection therewith, including attorney's fees.

9. Applicable Laws/Patents – Supplier represents and warrants that any and all materials and equipment are not produced, manufactured, sold, packaged, marketing, transported or priced in violation of any federal, state or local law and do not violate or infringe upon any patent, trademark or other rights of third parties. In the event that any third party asserts against Foreman Manhattan or Owner a claim for patent and/or trademark infringement, royalties or licensing fees with respect to use or sale of items purchased therein, Supplier agrees to defend and indemnify Foreman Manhattan or Owner for all costs, damages and expenses, including court costs and attorney's fees.

10. Acceptance of Order – This Order may only be accepted by Supplier signing and returning to Foreman Manhattan all copies of this Order within 10 days after the date of this Order. No modification of the terms of this Order shall be effective unless and until expressly accepted by Foreman Manhattan in writing.

11. Complete Agreement – This Order represents the entire agreement between the parties hereto with respect to the matters covered herein. No other previous agreements, representations, proposals, bid, warranties, or other matters, oral or written, shall be deemed to bind the parties hereto. The provisions of this Order are severable and if for any reason any provision or provisions herein are determined to be invalid, illegal or unenforceable, such determination shall not affect any other provision hereof.

12. Equal Opportunity

a. All work performed and/or materials supplied under this Order are subject to Foreman Manhattan's current Equal Opportunity Policy/Affirmative Action Plan. Copies of this policy shall be made available to the Supplier on request.

b. Supplier shall include the provisions of this Article 12 in Supplier's Agreements. The requirements of this Article 12 shall be in addition to any Equal Opportunity provisions of the Contract Documents.

13. Changes – Foreman Manhattan may, at any time, unilaterally or by agreement with Supplier, without notice to the sureties, make changes in the work covered by this Order. Payment on account of such changes in any way relating to or arising from any act or omission of the Owner or involving the Contract Documents shall only be made if, when and to the extent Foreman Manhattan receives payment from the Owner on account of the change. Payment by Owner is a condition precedent to entitlement of Supplier to payment for such changes. Changes directed by Foreman Manhattan independent of the Owner and the Contract Documents shall be paid for in accordance with the payment terms set forth herein or, in the absence thereof, shall be a reasonable amount. Supplier shall only be allowed to recover its direct costs for any such change and without overhead or other markup. Supplier agrees to provide any certifications reasonably required by Foreman Manhattan and/or the Contract Documents including certification of claims, and to indemnify Foreman Manhattan for any and all liability arising from any false or misleading certifications submitted by Supplier.
14. Withholding of Payment – Foreman Manhattan may withhold amounts otherwise due under this Order, or under any other arrangement between the parties, to cover Foreman Manhattan's reasonable estimate of any costs, liquidated damages or liability Foreman Manhattan has incurred or may incur for which Supplier may be responsible under this Order or under any other arrangement between the parties. Appropriate adjustments to withholdings shall be made when the exact amounts owed are determined.
15. On-Site Work – If Supplier's workers will be at the job site at any time, upon the request of Foreman Manhattan, Supplier agrees to provide insurance coverage acceptable in all respects to Foreman Manhattan, waiving subrogation, and for liability coverage, naming Foreman Manhattan as additional insured party, as well as complying with Foreman Manhattan's safety policies. The insurance requirements are attached hereto as an Exhibit. Supplier agrees to adhere to the requirements of Foreman Manhattan's Drug-Free Workplace Program.
16. Shop Drawings/Submittals – Supplier shall deliver to Foreman Manhattan copies of shop drawings, cuts, samples, material lists and other submissions required by Foreman Manhattan, the Architect, Owner or the Contract Documents within sufficient time so as not to delay performance of the Project. Foreman Manhattan's review or approval of shop drawings, cuts, samples, material lists and other submissions shall not relieve Supplier from responsibility for errors or deficiencies of any sort therein, nor from the necessity of furnishing any materials, equipment and/or work required by the Contract Documents, nor shall such submissions alter the requirements of the Contract Documents. Supplier further agrees to furnish operating and maintenance manuals, warranties naming both Foreman Manhattan and the Owner, guaranties and any other documents as required by the Contract Documents at the time of delivery.
17. Taxes – Except as otherwise provided by this Order and/or the Contract Documents, Supplier agrees to pay and comply with and hold Foreman Manhattan harmless against the payment of all Federal, state, and local contributions, taxes, duties or premiums arising out of this Order and all sales, use or other duties or taxes of whatever nature levied or assessed against the Owner, Foreman Manhattan or Supplier arising out of this Order, including interest or penalties.
18. Title and Risk of Loss – Title to all materials and/or equipment to be supplied under this Order shall be transferred free and clear of all encumbrances and Supplier shall retain no legal or equitable interest in any such materials and/or equipment. Title shall pass to Foreman Manhattan or, if the Contract Documents so provide, the Owner upon the earliest of (a) delivery, (b) payment, or (c) the time set forth in the Contract Documents. Regardless of title, Supplier shall have the sole responsibility for risk of loss with respect to the materials and/or equipment until final acceptance by the Owner or Foreman Manhattan.
19. Condition Precedent to Payment – Supplier shall not be entitled to any payment from Foreman Manhattan unless and until Foreman Manhattan has received payment for Suppliers' work from Owner. Receipt of payment from Owner shall be an express condition precedent to any payment obligation of Foreman Manhattan to Supplier, provided, however, that Foreman Manhattan will not use this condition precedent as a defense to any payment obligation if the reason for the withholding by the Owner is based on the work of Foreman Manhattan, or the work of any subcontractor of Foreman Manhattan, and unrelated to any deficiencies in the materials, equipment and/or work furnished by Supplier. If Foreman Manhattan has furnished a payment bond on the Project, its surety shall have all defenses of Foreman Manhattan to any obligations to Supplier, including, but not limited to, the failure of Foreman Manhattan to receive payment from the Owner. Nothing herein shall restrict any right of Supplier to file a mechanic's or materialmen's lien to the extent allowed by law.

20. Dispute Resolution – At the option of Foreman Manhattan, any and all disputes between the parties shall be resolved by arbitration in accordance with the Construction Industry Rules of the American Arbitration Association. If arbitration is elected, Supplier agrees that joinder of other parties will be allowed with respect to any such arbitration if any other disputes involve common questions of law and fact. Any demand for arbitration must be filed no later than the time in which litigation would be barred pursuant to any statute of limitation or repose. The prevailing party, in any dispute between the parties, shall be entitled to an award of reasonable attorneys' fees and costs. For a party to prevail on a claim, it must be awarded a substantial amount of its claim. For a party to prevail against a claim, it must successfully defend against a substantial amount of the claim.

FOREMAN | MANHATTAN

Construction Team

CNE TAHLEQUAH CASINO

EXHIBIT "A"
 FOR PURCHASE AGREEMENT BETWEEN
 FOREMAN MANHATTAN CONSTRUCTION TEAM AND
 SUPPLIER.

APPLICABLE SPECIFICATIONS:	
DIVISION 00 – Introductory Information and Bidding Requirements	Complete
Legends, Notes and Schedules per Plans and Specifications	As Applicable
Geotechnical Engineering Report	As Applicable
Terminology:	
Contractor and/or Supplier shall mean work Package Bidder. Construction Manager (CM) shall mean Foreman Manhattan Construction Team.	
ADDENDUMS INCLUDED:	
ALTERNATE # ACCEPTED:	
GENERAL SCOPE OF WORK:	
Includes, but is not limited to, providing all the necessary materials necessary to provide the SCOPE ITEMS at the Parish of Christ the King in Tulsa, Oklahoma , in accordance with the Contract Documents. It is further understood and agreed that this Supplier also includes the furnishing of the below listed items regardless of whether or not they are in the listed specification section(s) or any other specification section(s), or shown on the plans. Drawing and detail references are provided for reference only and are not to be considered as all inclusive of Contract Documents for the particular items referenced. (Please note: The word "provide" when used herein shall mean furnish completely all material necessary to complete the work".)	
1. s	
2. Materials incorporated into the project are exempt from Sales and Use Taxes. Subcontractor shall submit invoices in the format required by the CM. The XXXX will make direct payment to material vendors for exempt material. Subcontractor shall include and pay all other applicable sales and use taxes, as required.	
3.	
PURCHASE CONTRACT BREAKDOWN:	
Base Bid	\$
Purchase Contract Amount	\$
CONTRACTOR'S OPTIONS:	
At the option of Foreman Manhattan, Supplier will add (or delete) the following items of work:	
1. 8-Foot Chain Link Fence with 2 3/8", Schedule 40 Posts and Top Rail	\$ 10.33 Per foot
SCOPE OF WORK EXCLUSIONS:	
The following items are excluded from this Purchase Contract:	
1.	
SPECIAL TERMS AND CONDITIONS:	
1.	

Exhibit "B"

Bond No. _____
Premium _____

SUPPLY CONTRACT BOND

The following affidavit is to accompany the bid:

KNOW ALL MEN BY THESE PRESENTS, That _____ as Principal and
_____ as Surety, are held
and firmly bound unto FOREMAN MANHATTAN CONSTRUCTION TEAM as Obligee, in the penal sum of
_____ DOLLARS (\$ _____), lawful money of the
United States, for the payment of which sum well and truly, to be made, we bind ourselves, our heirs, executors, administrators, successors
and assigns, jointly and severally, firmly by these presents.

WHEREAS the Principal has entered into a supply contract dated _____
with the Obligee for furnishing _____

NOW, THEREFORE, THE CONDITION OF THIS OBLIGATION is such that, if _____
principal shall faithfully perform said supply contract according to its terms, covenant and conditions, then this obligation shall be null and void;
otherwise it shall remain in full force and effect.

Signed, sealed and dated

ATTEST:

(Principal) (Seal)
By _____
(Signature)

(Typed Name and Title)

WITNESS:

(Surety) (Seal)
By _____
(Attorney In Fact)

(Typed Name)

FOREMAN | MANHATTAN Construction Team

Exhibit C

Foreman - Manhattan Construction Team

PURCHASE CONTRACTS MINIMUM INSURANCE REQUIREMENTS

PROJECT: Cherokee Nation Entertainment Tahlequah Casino
PROJECT NUMBER: 3882
PROJECT OWNER: Cherokee Nation Entertainment, LLC.

Commercial General Liability (Occurrence Basis)

General Aggregate Limit	\$2,000,000
Products & Completed Operation Aggregate Limit	\$2,000,000
Personal Injury Limit	\$1,000,000
Each Occurrence Limit	\$1,000,000

Foreman - Manhattan Construction Team, Manhattan Construction Company, Foreman Construction Management & Consulting, Cherokee Nation Entertainment, LLC. (its parent, subsidiary, & affiliated companies), Architect (James R. Childers Architect, Inc.) and others are to be included as an Additional Insured (CG2015 or Equivalent)

Insurance is Primary and Non Contributory

Business Auto Liability

Combined Single Limit for Bodily Injury & Property Damage (Above to include Owned, Hired and Non-Owned Auto)	\$1,000,000
---	-------------

Workers' Compensation/Employer's Liability

Each Accident	\$1,000,000
Disease Limit - Policy	\$1,000,000
Disease Limit - Each Employee	\$1,000,000

Umbrella Liability or Excess Policy (Occurrence Basis)

Combined Single Limit	\$1,000,000
-----------------------	-------------

(Over/above General, Auto and Employer's Liability Limits)

Umbrella or Excess Policy follows form over all GL, Auto and Employers Liability policies

VENDORS DELIVERING THEIR OWN PRODUCTS

In addition to the requirements above, any vendor delivering and unloading their own products will provide a Waiver of Subrogation in favor of Foreman - Manhattan Construction Team, Manhattan Construction Company, Foreman Construction Management & Consulting, Cherokee Nation Entertainment, LLC. (its parent, subsidiary, & affiliated companies), Architect (James R. Childers Architect, Inc.) and others on the General Liability, Auto and Workers Compensation Policies. Additional Insured status will be provided on the General Liability, Auto and Umbrella in favor Foreman - Manhattan Construction Team, Manhattan Construction Company, Foreman Construction Management & Consulting, Cherokee Nation Entertainment, LLC. (its parent, subsidiary, & affiliated companies), Architect (James R. Childers Architect, Inc.) and others.

CERTIFICATE OF LIABILITY INSURANCE

DATE (MM/DD/YYYY)

THIS CERTIFICATE IS ISSUED AS A MATTER OF INFORMATION ONLY AND CONFERS NO RIGHTS UPON THE CERTIFICATE HOLDER. THIS CERTIFICATE DOES NOT AFFIRMATIVELY OR NEGATIVELY AMEND, EXTEND OR ALTER THE COVERAGE AFFORDED BY THE POLICIES BELOW.

IMPORTANT: If the certificate holder is an ADDITIONAL INSURED, the policy(ies) must be endorsed. If SUBROGATION IS WAIVED, subject to the terms and conditions of the policy, certain policies may require an endorsement.

PRODUCER: MGP INSURANCE RIDER FOR ALL CONTRACTUAL INSURANCE REQUIREMENTS
CONTACT NAME:
PHONE (A/C, No, Ext):
FAX (A/C, No):
E-MAIL ADDRESS:
INSURER(S) AFFORDING COVERAGE
NAIC #

COVERAGES

CERTIFICATE NUMBER:

REVISION NUMBER:

THIS IS TO CERTIFY THAT THE POLICIES OF INSURANCE LISTED BELOW HAVE BEEN ISSUED TO THE INSURED NAMED ABOVE FOR THE POLICY PERIOD INDICATED. NOTWITHSTANDING ANY REQUIREMENT, TERM OR CONDITION OF ANY CONTRACT OR OTHER DOCUMENT WITH RESPECT TO WHICH THIS CERTIFICATE MAY BE ISSUED OR MAY PERTAIN, THE INSURANCE AFFORDED BY THE POLICIES DESCRIBED HEREIN IS SUBJECT TO ALL THE TERMS, EXCLUSIONS AND CONDITIONS OF SUCH POLICIES.

Table with columns: INSR LTR, TYPE OF INSURANCE, ADDL INSR, SUBR WVD, POLICY NUMBER, POLICY EFF, POLICY EXP, LIMITS. Includes rows for General Liability, Automobile Liability, Umbrella/Excess Liability, and Workers Compensation.

Check Correct Box

DESCRIPTION OF OPERATIONS / LOCATIONS / VEHICLES
Project Name: Cherokee Nation Entertainment Tahlequah Casino
Project Owner : Cherokee Nation Entertainment, LLC.
MCC Project Number: 3882
* See Notepad for additional requirements *

CERTIFICATE HOLDER

CANCELLATION

Foreman - Manhattan Construction Team
5601 S. 122nd E. Ave
Tulsa, OK 74146
SHOULD ANY OF THE ABOVE DESCRIBED POLICIES BE CANCELLED BEFORE THE EXPIRATION DATE THEREOF, NOTICE WILL BE DELIVERED IN ACCORDANCE WITH THE POLICY PROVISIONS.
AUTHORIZED REPRESENTATIVE

NOTEPAD:HOLDER CODE
INSURED'S NAME**OP ID:**PAGE 2
Date

Additional Insured in favor of Foreman - Manhattan Construction Team, Manhattan Construction Company, Foreman Construction Management & Consulting, Cherokee Nation Entertainment, LLC. (its parent, subsidiary, & affiliated companies), Architect (James R. Childers Architect, Inc.) and others as required by written contract on GL.

Excess and/or Umbrella follows form.

General Liability is primary and non-contributory to any other insurance available to the Additional Insureds.

Waiver of Subrogation in favor of Foreman - Manhattan Construction Team, Manhattan Construction Company, Foreman Construction Management & Consulting, Cherokee Nation Entertainment, LLC. (its parent, subsidiary, & affiliated companies), Architect (James R. Childers Architect, Inc.) and others as required by written contract on GL and WC Policies.

Workers Compensation Coverage covers ALL employees of the insured in the state where work is being performed.

EXHIBIT "G"
Tax Exempt / Owner Direct Paid Invoice (ODPI) Payment Process

1. Identify supplier/vendors eligible for tax exemption process. Eligible supplier/vendors are providers of materials to the construction of CNE Tahlequah Casino and who remit taxes to OTC.
2. Provide list of supplier/vendors to Manhattan by executing Change Notice to the Contract between Manhattan.
3. CNE Tahlequah Casino to issue Tax Exemption Letter to each vendor. Letter to indicate contractual relation between CNE Tahlequah Casino, Manhattan, & Vendors.
 - Tax Exempt Entity – CNE Tahlequah Casino
 - Contractor (Tier 1) – Manhattan Construction Company
 - Contractor (Tier 2) – Subcontractors of Manhattan
 - Contractor (Tier 3) - All suppliers/vendors providing materials
4. Purchase Orders for materials shall clearly state that the purchase is being on behalf of the CNE Tahlequah Casino and that the material is necessary for the construction of the CNE Tahlequah Casino.
5. Subcontractor's Schedule of Values (G703) shall clearly identify all Invoices submitted as Tax Exempt, under column titled Owner Paid Materials.
6. Subcontractor shall include the supplier's/vendors W9 with the pay application.
7. Tax Exempt Invoice will be submitted monthly to Manhattan Construction Company. All invoices shall be listed on Tax Exemption Summary Sheet, to be submitted with each pay application (Format attached).
8. Manhattan shall submit monthly pay application for review and approval to the Design Professional. Approved pay application will be forwarded to CNE Tahlequah Casino for payment.
9. CNE Tahlequah Casino to issue checks made out to the supplier / vendor for all ODPI invoices. Checks will be delivered to Manhattan for distribution. Manhattan will distribute payments and collect Lien Waivers.

Exhibit "H" – Foreman Manhattan Construction Team - Additional Safety Requirements

All suppliers, their employees and non-employee visitors, when on site, shall adhere and comply with all OSHA, Owner and Foreman Manhattan Project Safety requirements. This includes, but is not limited to compliance with the following Safety Rules that may exceed OSHA requirements:

Personal Protective Equipment (PPE)

- OSHA-approved eye protection including side shields on eyeglasses are required to be worn while on the project site, except for personnel enclosed within a motor vehicle or within a temporary office.
- Hardhats (ANSI-Approved z-89.1, class E & G) and hard soled shoes or boots shall be worn at all times.
- Electronic Devices, including, but not limited to radios, MP3 players, smartphones, etc. used for entertainment are not allowed on the jobsite.
- Texting, emailing or other mobile phone use is prohibited while operating any equipment.

Fall Protection

- All workers shall be protected by 100% fall protection above six (6) feet.
- When working on all ladders, employees shall be tied-off 100% of the time when working closer than one and one-half (1-1/2) times the ladder height to an opening or the edge of the building.
- Employees shall be tied off 100% of the time when working on straight ladders or when building scaffolds above six (6) feet.

Scaffolds

- Upon completion, scaffolds shall have and maintain a scaffold permit attached to the scaffold in full visibility of all employees at the access to the scaffold.
- Mobile scaffolds are not to be moved while a person and/or persons are on the scaffold. Additionally, scaffolds are not to be scooted (surfed) by the person on scaffolding.

Crane Policy

- Load Moment Indicators (LMI) must stop crane operations in the event of an impending overload and are required on all cranes as specified in OSHA 1926.1400. Scales, load cells, and audible warning devices are not acceptable LMI alternatives.
- Anti-two-block devices must stop crane operations in the event of an impending two-block and are required on all cranes as specified in OSHA 1926.1400. Scales, load cells, and audible warning devices are not acceptable anti-two-block alternatives.
- Tower cranes, derricks and lattice boom cranes shall be certified annually and prior to being put into service when they are initially erected and delivered to the jobsite, reconfigured, altered, climbed, or extensively repaired. Certifications are to be completed by a third party competent person, government or private agency recognized by the U. S. Department of Labor to perform such inspections.

Safety Vests | Highly Visible Clothing

- As an addition to and in no way diminishing any government requirement, visibility safety vests or other equal shirts or jackets of MUTCD Class II, shall be worn at all times on Foreman Manhattan projects when the other basic PPE items of hard hats and safety glasses are required. Uniform highly visible shirts without reflective bands may be allowed when not required by regulations and meeting the minimum standards for the job set by the Foreman Manhattan superintendent.

Safety Training

- Supplier agrees to conduct a weekly safety training session for upcoming work activities or job conditions with his entire crew, and submit minutes with attendance noted of said meeting to Foreman Manhattan on a weekly basis.
- Supplier, their employees, tiered subcontractors, suppliers and non-employee visitors are to participate in the Site-Specific Safety Plan (SSSP) orientation program video (30 minutes for employees and 5 minutes for visitors).

EXHIBIT "I"
For Projects in Oklahoma only

PAGE 2, PARAGRAPH 4, LIABILITY AND INDEMNIFICATION – DELETE:

“regardless of whether or not such injury or damage was due to the sole negligence of supplier, its employees, agent, subcontractors or suppliers, or involved the concurring negligence of Foreman Manhattan Construction Team, its agents, employees, or subcontractors; provided, however that such indemnity shall not cover injury or damage caused entirely by the negligence of Foreman Manhattan Construction Team, its agents or employees”.

INSERT IN ITS PLACE THE FOLLOWING:

“THIS INDEMNIFICATION APPLIES EVEN THOUGH THE MATTER TO BE INDEMNIFIED IS THE RESULT OF THE CONCURRENT NEGLIGENCE OF FOREMAN MANHATTAN CONSTRUCTION TEAM, OWNER AND THEIR EMPLOYEES, SERVANTS, AGENTS, PROVIDED, HOWEVER, THAT WITH RESPECT TO LIABILITY FOR DAMAGE ARISING OUT OF DEATH OR BODILY INJURY TO PERSONS OR DAMAGE TO PROPERTY, THE INDEMNIFICATION REQUIRED OF SUPPLIER SHALL NOT EXCEED ANY AMOUNTS THAT ARE GREATER THAN THAT REPRESENTED BY THE DEGREE OR PERCENTAGE OF NEGLIGENCE OR FAULT ATTRIBUTABLE TO THE SUPPLIER, ITS AGENTS, REPRESENTATIVES, SUBCONTRACTORS OR SUPPLIERS.”

PROJECT SAFETY PLAN



CHEROKEE NATION™
Entertainment

FOREMAN | MANHATTAN
Construction Team

Tahlequah Casino

March 2018

PROJECT SAFETY PROGRAM

TABLE OF CONTENTS

I Project Safety Plan

- A. Purpose
- B. Basic Principles
- C. Responsibility
- D. Safety Meetings
- E. Accident Reporting Requirements
- F. Subcontractor Safety Enforcement Policy
- G. Visitors
- H. Conclusion

II Critical Work Plan

- A. Applicable Safety Standards
- B. Scope of Coverage
- C. Employee Orientation
- D. Hazard Communication Program
- F. Temporary Power
- G. Fall Protection
- H. Excavations
- I. Fire Protection
- J. Flammable/Combustible Liquids
- K. First Aid
- L. Medical Emergency
- M. Hand and Power Tools
- N. Scaffolds
- O. Ladders
- P. Lockout/Tagout
- Q. Accident Reporting
- R. Respirator Program
- S. Sanitation
- T. Cranes/Rigging
- U. Floor and Wall Openings
- V. Masonry Walls
- W. Housekeeping

III Foreman Manhattan Construction Team (FMC) Forms

- Safety Audit log
- Weekly Project Audit
- Daily Excavation Report
- Mobil Crane Inspection form
- Lift Calculation Form
- Accident Investigation Report

IV Crisis Management Plan

Section 1

Project Safety Plan

1. **Project Safety Plan**

A. Purpose

1. Prevention of accidental injury, occupational illness and property damage and to establish methods whereby all Project employees will be actively involved in the safe construction of the Project.
2. Assure that all participating Subcontractors comply with the requirements of the Authority Having Jurisdiction at the point of operations within the construction zone.
3. Outline the safety duties and responsibilities of all parties on this Project.
4. Establish and implement a plan for safety education, training and monitoring to promote identification and elimination of hazards and unsafe acts.

B. Basic Principles of the Project Safety Plan

1. All Subcontractors shall ensure that their employees, subcontractors and suppliers, regardless of tier, understand and agree to comply with their Company Safety Program, the Project Safety Plan, the Project Documents, OSHA Standards and all other federal, state and local codes and regulations.
2. Prior to beginning work, each Subcontractor shall prepare a Hazard Analysis that defines the activity to be performed and identify the sequence of work, the specific hazards, and methods to be used to eliminate or minimize each hazard. The Hazard Analysis shall be reviewed by the Site Safety Manager and/or the Project Superintendent or their designated representatives.
3. All major subcontractors, such as Excavating, Pier Drilling, Structural Steel, Form Work, Mechanical, Electrical, Elevator, Plasterer/Drywall, Painting, Glazing, Roofing, Brick Mason/Masonry and Fire Protection must submit a Site Specific Safety Program to the FMC site management prior to the start of their work. All second and third tier subs shall adhere to their contract requirements; specific safety plan may be required for specific situations.
4. All Subcontractors shall provide their employees with the necessary safety and personal protective equipment and weather protective gear required for the performance of their work and enforce the use of same as a condition of employment. Hard hats and Hi-Vis garments are required to be worn at all times where construction activities are taking place. The wearing of eye protection with side-shields is required at all times. Required special equipment such as Personal Fall Protection or Respiratory Protection shall have specific plans that are administered by the subcontractor.
5. Each Subcontractor shall have at least one employee qualified in First Aid/CPR treatment whenever the Subcontractor has employees working on this project. Subcontractor is required to provide basic First Aid supplies for the number of employees he has on the job.
6. For emergency purposes, each Subcontractor shall submit a list to the Project Manager of key personnel with home addresses and telephone numbers.

C. Responsibility

1. Project Manager shall:
 - a. Be responsible for the administration of the Project Safety Program.
 - b. Assist the Project Superintendent and the Project Site safety coordinator with all matters pertaining to safety when deemed necessary and as required.
2. Project Superintendent shall:
 - a. Enforce compliance with the Project Safety and HAZCOM Programs, the Project Documents, OSHA Standards and all other federal, state and local safety codes and regulations.
 - b. Distribute an Emergency Response Plan for this project to all Subcontractor Safety Representatives and post copies in all trailers and offices. These Procedures shall be discussed at the Project Safety Meetings and shall be a required subject for a Toolbox Talk for all Project employees.
 - c. Identify facilities for immediate first aid and/or medical/hospital treatment for all work related injuries and illnesses of employees.
 - d. Regularly inspect the Project for safety compliance.
 - e. Schedule weekly Project Safety Meetings.
 - f. Receive all safety related correspondence and accident reports.
3. Site Safety Coordinator shall:
 - a. Make daily safety inspections, ensuring coverage of the entire project each week, with a weekly written report.
 - b. Notify responsible persons regarding noncompliance with the Project Safety and HAZCOM Programs, the Project Documents, OSHA Standards and all other federal, state and local safety codes and regulations.
 - c. Implement and enforce the Safety Enforcement Policy.
 - d. Check with Sub Safety Rep. on disposition of safety related matters.
 - e. Render assistance at FMC and Subcontractor Toolbox Talks.
 - f. Investigate all accidents as directed by the Project Superintendent.
 - g. Issue weekly Safety Bulletins regarding pertinent safety issues.
 - h. Maintain records of all FMC and Sub Safety and Toolbox Meetings.
 - i. Assist the Project Superintendent with all safety related matters.
 - j. Shall keep a Log of First Aid Treatment.
4. Subcontractor Safety Representative(s) shall:

- a. Ensure that their employees are trained to perform their work in a safe manner and have the ability to recognize and correct potential and actual hazards.
- b. Be responsible for the Sub Accident Reporting Requirements.
- c. Attend each weekly Project Safety Meeting.
- d. Chair their weekly Toolbox Talks or mandate that all their personnel attend the hosted weekly tool-Box Talk at 7am every Tuesday. Arrange for written minutes to be taken and copy these minutes to the Project Site safety coordinator.
- e. Work with the Project Superintendent to participate in safety audits as required.
- f. Report all safety related matters to the Project Site Safety Coordinator or Superintendent.

5. All Project Employees shall:

- a. Perform their work in a safe manner for prevention of accidents to themselves, fellow workers, the general public and property of all concerned.
- b. Attend their weekly Company Toolbox Talks.
- c. Alert their Foremen of hazards, unsafe acts and near misses.
- d. Notify their Foremen immediately of any accident.
- e. Comply with their Company Safety and HAZCOM Programs, the Project Documents, OSHA Standards and all other federal, state and local codes and regulations.
- f. All Project Employees shall be subject to fair, consistent and constructive disciplinary action for safety noncompliance. The severity of a violation shall determine the level of disciplinary action administered. See the Guide to Disciplinary Action on the next page.

The typical disciplinary action pattern is as follows:

- (1) Verbal Reprimand: The employee shall be informed verbally of the safety violation committed which, if repeated, could result in further disciplinary action.
- (2) Written Reprimand: The employee shall be notified by formal written notice of the safety violation committed and informed that future violations may result in suspension or discharge from work.
- (3) Suspension: The employee shall be suspended from working on the site for a specified period of time for the safety violation committed and informed that future violations may result in permanent removal from the project.

(4) Termination: The employee shall be barred from the project as a result of a major safety violation or a pattern of safety violations.

GUIDE TO DISCIPLINARY ACTION				
	MINOR	SIGNIFICANT	SERIOUS	FLAGRANT
SEVERITY OF INFRACTION EXAMPLES	<ul style="list-style-type: none"> - Not wearing safety glasses - Not wearing hard hat - Not wearing hearing protection 	<ul style="list-style-type: none"> - Horseplay - Crossing a red barricade 	<ul style="list-style-type: none"> - Not tying off - Using incomplete scaffold - Endangering another employee 	<ul style="list-style-type: none"> - Knowingly endangering another employee - Fighting
SEVERITY OF INFRACTION DEFINITIONS	A safety violation that does not immediately expose an employee to serious injury or death.	A safety violation in which the employee exposed self or others in a significant risk of injury.	A safety violation in which an employee exposed self or others to risk serious injury or death.	A safety violation in which an employee has committed an inexcusable unsafe act.
FIRST OFFENSE	VERBAL REPRIMAND	WRITTEN REPRIMAND	SUSPENSION	TERMINATION
SECOND OFFENSE	WRITTEN REPRIMAND	SUSPENSION	TERMINATION	
THIRD OFFENSE	SUSPENSION	TERMINATION		
FOURTH OFFENSE	TERMINATION			

E. Safety Meetings

1. Weekly Project Safety Meeting

- a. The Project Superintendent shall schedule a weekly Safety Meeting to review accidents, injuries, and near misses, review safety related problems and plan for upcoming work activities. This will be combined with the weekly subcontractor meeting at 9am every Monday.
- b. The Project Safety Meeting should be attended by supervisory personnel.
- c. Activity Hazard analysis shall be collected from subcontractors at the meeting and any conflicts discussed.

2. Weekly Toolbox Talks

- a. FMC will conduct a weekly Tool-Box Talk at 7am on Tuesday, Subcontractors are welcome to attend or they may hold weekly Toolbox Talks of their own. The topics of these talks shall be relevant to the work being performed by the supervisor's crew.

- b. Documentation of the weekly Toolbox Talk shall be submitted to the Project Superintendent before 3:00 P.M. each Friday.
- c. The weekly Toolbox Talk Minutes shall contain the following:
 - (1) Name of Employer and date.
 - (2) Name of the FMC Foreman or Subcontractor Safety Rep.
 - (3) Name of all employees in attendance.
 - (4) Subjects discussed.
 - (5) Safety comments and suggestions from employees.
- d. The weekly Toolbox Talk Agenda shall include, as a minimum, the following:
 - (1) Instruction in the safe planning and performance of their work.
 - (2) Review of Project accidents, near misses, hazards and unsafe acts.
 - (3) Employee suggestions and comments relating to safety.

F. Accident Reporting Requirements

1. Project Employee Injury:

- a. All on-site accidents, regardless of how incidental, including those sustained by Subcontractors, shall be reported to the Superintendent Immediately. Subcontractors shall include proper FMC site personnel as part of their First Call List for notification any time emergency response (Fire, Ambulance, police) are required.
- b. Non-incident injuries and near misses shall be reported within 24 hours to FMC in writing as an accident/incident report that contains the following:
 - Names and addresses of victims and witnesses.
 - Description of events leading up to the accident/incident.
 - Factors that may have contributed to the accident/incident.
 - Action taken to prevent this accident/ incident in the future.
- c. The Site Safety Coordinator or Project Superintendent shall notify the Owner's Designated Rep. of all recordable injuries to any person. The notification shall describe the circumstances of the accident and any corrective action taken. The written notification shall be within 24 hours of any injury.
- d. Subcontractors shall be responsible for notifying OSHA within eight (8) hours in the event of a fatality or a single accident in which three (3) or more employees are hospitalized.

G. Subcontractor Safety Compliance Program

1. All Subcontractors shall, prior to their start of work, submit the names of their authorized and qualified Project Safety Representatives to the FMC Project Superintendent. All Project Safety Representatives shall be held accountable by their Companies for the immediate correction of hazards and unsafe acts and compliance with their Company Safety and HAZCOM Programs, the Project Documents, OSHA Regulations and all other federal, state and local codes and regulations by their employees and their subcontractors and suppliers, regardless of tier.
2. All subcontractor employees working on the project shall receive FMC Safety Orientation training prior to their first full day of work. Completion of the orientation

shall be marked with a hard-hat sticker. This sticker is site specific and not transferable to other FMC sites. Refer to item "c" in the following *Critical Work Plan*

3. Consistent with the Employee Compliance program, written warnings for subcontractor employee safety violations will be documented using the safety warning form, referenced at the back of this document.
4. To address recurring subcontractor safety violations, corrective action may include but is not limited to any of the following:
 - a. A stop work order for the specific operation or area of construction until the hazard or unsafe act is corrected.
 - b. Correction made by FMC or others and backcharged to the Subcontractor.
 - c. Written notice to the Subcontractor's Project Manager and Company President.
 - d. Replacement of the Subcontractor's Project Safety Representative, Foremen and/or crew.

H. Visitors

1. Persons not directly involved with the on-site construction of this Project shall not enter the site unless they are escorted by properly designated employee and obtain and wear a hard hat, vest and any other personal protective equipment required.

I. Conclusion

1. All employers are responsible for instructing their employees in the recognition and elimination of hazards and unsafe acts and the regulations applicable to their work.
2. Safety training, good safety practices and appropriate immediate corrective action are the keys to the prevention of accidents, loss of life and property damage. No matter how many rules and regulations are set forth, a good Safety Program depends mainly on a positive and intelligent attitude by the Management and Labor involved in the construction of this Project.

Section 2

Critical Work Plan

II Critical Work Plan

The elements of this plan address some of the potential hazards associated with the scope of work and provide guidelines to eliminate or minimize those hazards.

A. Applicable Safety Standards

1. All work shall be performed in accordance with the safety and health requirements set forth in the Code of Federal Regulations (CFR) Title 29, Part 1926, "Safety and Health Standards for the Construction Industry", and Title 29, Part 1910, "General Industry Safety and Health Standards", as well as the applicable state and local regulations.
2. Copies of the applicable OSHA standards will be made available at the site.
3. Additional requirements above the minimum standard of OSHA are described in the subcontract.

B. Scope of Coverage

1. This plan shall apply to all contractors, subcontractors, suppliers, and lower tier subcontractors and their employees while performing work activities on this project.

C. Employee Orientation

1. Each employer is responsible for ensuring that their employees are properly oriented:
 - Orientations shall be given to each employee on the project prior to that employee performing work.
 - Orientations shall be documented and copies shall be submitted to FMC following their completion.
 - Orientations must address specific jobsite conditions and cover all applicable FMC safety policies, local, state and federal regulations as well as authority having jurisdiction.
2. Each employee shall be provided an initial orientation that will address training and other information that will allow them to perform their work in a safe manner. The orientation shall be based on elements of this *Plan*.
3. Below is a list of the minimum topics of training. This list is not all-inclusive and shall not be considered to identify all hazards associated with construction.
 - a. Employees responsibility to work safely.
 - b. Elements of the Project Safety Plan that apply to their work.
 - c. FMC Disciplinary Action Policy
 - d. Mandatory personal protective equipment (hard hats, Vest, safety glasses, safety harnesses, etc.)
 - e. Procedure for reporting accidents/injuries.
 - f. Hazard Communication Program.
 - g. Rules and regulations for operating motor vehicles inside fence.
 - h. No Gas, CNG or Propane powered equipment.
 - i. Mandatory attendance at Safety Meetings.
 - j. How and when to use Fire Protection Equipment (fire extinguishers).
 - k. No Radios (For personal Music)

D. Hazard Communications Programs

1. Foreman - Manhattan Construction Team (FMC)

- a. By reference of the FMC Hazard Communication Program, it is hereby incorporated in its entirety in the *Project Safety Plan*.
- b. A copy of the OSHA Hazard Communication Standard 1926.59, the Hazard Communication Program, Hazardous Chemical Inventory List and all Material Safety Data Sheets (MSDS) shall be located in the Project Field Office.

2. Subcontractors

- a. Each Subcontractor/Purchase Contractor and lower tier subcontractors must submit to FMC a written Hazard Communication Program as outlined in the Occupational Safety And Health (OSHA) Code of Federal Regulations 1926.59. All Hazard Communication Programs submitted to FMC
- b. must have the following elements and be divided accordingly:
 - (1) A written HazCom program.
 - (2) Provisions for employee training. Employers need to be able to certify that their employees have been trained in all aspects of HazCom.
 - (3) An alphabetical listing of the hazardous materials that the Subcontractor will be bringing onto this Project.
 - (4) Copies of Material Safety Data Sheets for the hazardous materials that the Subcontractor will be bringing onto this Project.

Whenever new products are brought on site by the Subcontractor, the Subcontractor's HazCom Coordinator will be responsible for bringing the Subcontractor's program up to date.

The information requested above must be submitted in book format with the company name, the name of a contact person (HazCom Coordinator) familiar with the HazCom program, and applicable telephone numbers, listed on the front cover.

E. Working in Confined Spaces

1. When it becomes necessary to enter and conduct work activities in a confined space, a Confined Space Entry Program shall be enforced.

F. Temporary Electric Power

1. Temporary power shall be in compliance with the NEC and CFR 29, 1926, Subpart K. and NFPA 70E.
2. All branch circuits supplying 120 volts single phase to 15 and 20 amp receptacles shall be protected with GFC Interrupters.

3. Employees shall inspect the cords to electric power tools and extension cords prior to each use and shall remove from service any cords found to be defective.

G. Fall Protection

1. Employees shall be protected from the hazards of falling in accordance with OSHA regulations and FMC Safety requirements. Standard guardrails, lifelines, floor covers and personal protective equipment shall be used to meet this requirement at any elevated work over 6'.
2. Personal fall protective equipment such as safety belts, safety harnesses, lanyards, and life lines shall be inspected by the wearer before each use. Employer shall be responsible for training and documentation of all employees who use the equipment. This will include; proper fit and adjustment, sizing, anchorage, lanyard usage.
3. To further fall protection measures, FMC has implemented the following requirements to be applied to all project employees:
 - All employees, subcontractors, vendors, suppliers, and owners on a working/walking surface 6-feet or more above a lower level shall be protected by the 100% fall protection policy.
 - This 100% fall protection policy extends beyond OSHA regulations to include structural steel ironworkers and scaffold builders.
 - Acceptable fall-protection methods include personal fall-arrest systems (2 lanyards required), properly- built scaffolds, guardrail systems, safety nets, warning line systems, controlled access zones. The Project Superintendent shall review Subcontractor fall protection plans in the context of job hazard analysis discussions.
 - All overhead work shall be confined to an area clearly marked by red barricade tape at the closest working surface below the overhead work activity.

H. Excavations

1. Each Subcontractor requiring employees to work in excavations shall provide a Competent Person as defined by OSHA in 29 CFR, Part 1926 Subpart P, "Excavations". The Competent Person must be familiar with the requirements of Subpart P and shall determine the type of protective system to be utilized and shall perform periodic inspections of the excavation.
2. Written daily excavation inspection reports shall be signed by the Competent Person and submitted to the FMC Project Superintendent or his designated representative.
3. FMC site personnel shall also complete "Daily Excavation Inspection Report" for each excavation at the site.

I. Fire Protection

1. FMC will maintain temporary portable fire extinguishing equipment for building protection. Fire extinguishers of the ABC type will be provided in the quantity and size required by CFR 29 1926.150. Subcontractors shall be responsible for providing fire protection for specific tasks as necessary including but not limited to cutting, welding, soldering, and roofing operations as well as flammable/combustible material storage areas.

2. All employees shall be instructed by their employer in the proper use of fire protection equipment. Documentation of such training shall be maintained by each employer.

J. Flammable and Combustible Liquids

1. All flammable/combustible liquids shall be stored and handled in accordance with CFR 29, 1926.152.
2. Gasoline shall be stored in approved metal safety cans that are equipped with a flash arresting screen and spring-closing lid. Cans stored on site shall remain locked in flammable's cabinet when not in use.
3. No Fuel shall be stored inside the building.
4. Fire Extinguishing equipment shall be available where flammable/combustible liquids are stored.

K. First Aid

1. Each employer shall have at least one (1) Certified First Aid/CPR trained employee on site when working on this project. Each employer shall maintain a suitable first aid kit for use by its employees.
2. FMC will maintain at least one (1) First Aid cabinet in the Project Field Office. All use of FMC First Aid supplies shall be reported to the FMC superintendent and recorded on the First Aid Log located with the cabinet.

L. Medical Emergency

1. Employees suffering non life-threatening injuries shall be transported to medical facilities by their employer.
2. For all life-threatening injuries or illnesses, the employer shall immediately call for medical assistance by notifying 911 and FMC site management.
3. Other emergency telephone contact numbers shall be posted. Any call to Dispatch shall be immediately reported to FMC personnel at site.
4. As soon as possible FMC site personnel shall complete "Accident Investigation Report".

M. Hand and Power Tools

1. Each employer is responsible for the condition of the tools their employees use. Employees must be instructed in the hazards and limitations associated with the tools they use. Hand and power tools must be inspected prior to each use and removed from service when found to be defective.
2. Hand and Power tools shall be used, inspected, and maintained in accordance with the manufacturer's instructions and shall be used only for the purpose for which they were designed.
3. Power tools designed to accommodate guards shall be equipped with the guards when in use. These guards may not be field modified or shortened.

N. Scaffolds

1. Scaffolds shall be erected, modified, and dismantled ONLY under the direction of a Competent Person and shall follow the OSHA regulations outlined in CFR 29 1926.451.
2. Employees erecting, dismantling, or working from scaffolding must maintain FMC's 100% fall protection policy.
3. Upon completion, scaffolds shall have and maintain a Green Tag scaffold permit attached to the scaffold in full visibility of all employees at the access to the scaffold.
4. It is the responsibility of the designated Competent Person to tag the scaffold as Red or Green and conduct all inspections.
5. Scaffolds that are incomplete, being modified, dismantled or that are damaged shall be barricaded off with red barricade tape and red tagged incomplete.
6. Scaffolds without tags shall be considered red tagged and not for use.
7. Standard guardrail systems including top rail, mid-rail, and toe-board shall be installed on all scaffolds in accordance with OSHA regulations. Scaffold platforms that employees are working from shall be completely decked over for the entire width of the scaffold.
8. In the event that scaffold configurations or physical obstructions make it impossible to install standard guardrail system, employers shall supply a personal fall arrest system or other means of fall protection.
9. Employees shall not be allowed to pass beneath scaffolds where work is being performed overhead unless appropriate measures have been taken to protect employees from falling material.
10. All overhead work shall be confined to an area clearly marked by red barricade tape at the closest working surface below the overhead work activity.
11. Manually propelled mobile scaffolds shall only be used on a hard, level surface that is free from debris and other obstructions that could pose a hazard. Employees shall not be allowed to ride on mobile scaffolds that are being moved.

O. Ladders

1. Ladders shall be used in accordance with the requirements of CFR 29, Part 1926.1053.
2. Employees required to use ladders shall be trained in accordance with CFR 29, Part 1926.1060.
3. Ladders used to access elevated work areas shall extend at least 36" above the landing and shall be secured to prevent displacement. Guard rail opening shall be properly designed at landing to prevent worker accidentally falling through opening.

4. Employees using ladders for access to elevated work areas shall not carry tools/materials when climbing up or down a ladder.
5. Employees shall be instructed not to stand above the top two rungs of step ladders.
6. Employees shall be tied-off 100% of the time when working closer than one and one-half (1-1/2) times the ladder height to an opening or the edge of the building. (e.g. an employee using a ten (10) foot stepladder must tie-off when fifteen (15) or less from the edge of a opening or the building).
7. Employees shall be tied off 100% of the time when **working** on straight (vertical) ladders. Extension ladders used at the proper 4/1 ratio where the user is positioned between the side rails are acceptable.

P. Lockout/Tagout

1. No employee shall work on any electrical, hydraulic, steam, or other pressurized system/equipment until the system/equipment is secured from operating and all stored energy has been released as described in Lock-Out Tag-Out procedure.
2. Electrical equipment or circuits that are de-energized shall be rendered inoperative and shall have tags attached at all points where such equipment or circuits can be energized. Tags shall be placed to identify the equipment or circuits being worked on.
3. Refer to OSHA 1910.147 for specific Lock-Out procedures.

Q. Accident Reporting Requirements

1. Project Employee Injury:
 - a. All on-site accidents, regardless of how incidental, including those sustained by Subcontractors, shall be reported to the FMC Project Superintendent or his designated representative.
 - b. Subcontractors shall be individually responsible for notifying OSHA within eight (8) hours in the event of a fatality or a single accident in which three (3) or more employees are hospitalized.

R. Respirator Program

1. Employers who allow or require their employees to wear respirators shall have a written respirator program in accordance with CFR Title 29, Part 1910.134.
2. Employees allowed or required to use respirators shall be trained in the proper selection, maintenance, and limitations of respirators. Each employee shall be fit tested before using a negative pressure respirator.
3. Voluntary users of respirators (including N95 dust masks) shall complete Respiratory standard Appendix D and file paperwork with employer.
4. Licensed Asbestos workers shall comply with Repertory Protection requirements of Abatement Project Design.

5. At no Times, are unauthorized workers permitted in the Asbestos Abatement areas.

S. Sanitation

1. Potable Water

- a. Employees shall be provided with an adequate supply of potable water. Where single use cups are provided, a trash container for used cups shall also be provided.
- b. Containers for potable water shall be conspicuously marked as containing potable water.

2. Toilet Facilities

- a. Toilet facilities shall be provided and maintained in accordance with OSHA regulations. Existing site toilets may not be accessible to all zones.

T. Cranes and Rigging

1. Each Subcontractor using a crane shall identify, in writing, their Competent Person who will be responsible for the proper set-up and operation of the crane. A copy of this document shall be kept in the crane at all times.
2. Rigging inspections shall be performed in accordance with CFR Title 29, Part 1926.251.
3. Rigging equipment shall be inspected before each days use by the Competent Person before each lift by the employee rigging the load.
4. Load Moment Indicators will be required on all cranes.
5. Lift calculations will be required for all lifts that are over 85% of the crane's capacity according to the crane manufacturer's load charts. This shall also be documented with the FMC "Lift Calculation Form."
6. Anti-2-bloc devices will be required on all cranes.
7. Flagger for the crane shall be trained in universal crane signals and shall have constant communication with the operator.
8. FMC "Mobil Crane Inspection Form" shall be used as a checklist by FMC site personnel prior to first lift of each new crane location.

U. Floor and Wall Openings

1. All floor and wall openings, 2 inches or greater in size, shall be guarded or covered. Guardrails shall be of standard construction as outlined in CFR Title 29, Part 1926.502.
2. When floor covers are used they shall be capable of withstanding the maximum intended load. Covers will be secured against displacement and marked to indicate "HOLE" or "COVER", or they shall be color coded.

3. Hole covers shall be constructed so that normal construction activities will not displace the cover from its location (wired, shot, nailed or bolted down).

V. Masonry Walls

1. Subcontractors erecting masonry walls shall do so in accordance with CFR Title 29, Part 1926.706.
2. Prior to erecting any masonry wall, a Limited Access Zone shall be established and maintained throughout construction of the wall.
3. All overhead work shall be confined to an area clearly marked by red barricade tape at the closest working surface below the overhead work activity.

W. Housekeeping

1. Job-site cleanliness is an item of major significance on this project and will be closely monitored.
2. Housekeeping shall be performed on a continuous basis. Waste materials such as wood, concrete, rebar, cardboard, plastic wrap, and other types of trash must not be allowed to accumulate and become a hazard.
3. Work areas must be kept clean AT ALL TIMES within the premises.

Operation Zero

Statement for Subcontracts

Operation Zero is a strategy to heighten the awareness of safety by each worker for all others, but in no way shall compromise any Regulatory Agencies' requirements and Foreman Manhattan Safety Policies and Over OSHA requirements. We understand all subcontractors and their respective workers share this same corporate mission, therefore we look forward to your support.

Foreman Manhattan and each subcontractor's corporate leadership will be asked to participate in a project specific effort to develop a site specific safety management plan, including a safety mission statement. Further, each Subcontractor should appoint a project site representation on the project safety team. Each key team member (subcontractors & Foreman Manhattan) will sign the mission statement which each project team develops, pledging to utilize the Operation Zero strategy to accomplish the project specific SMART goals.

Foreman Manhattan and subcontractors will use additional signage, posters, hardhat decals and other promotional items to let every worker know that safety is a personal and professional commitment everyone needs to make.

Operation Zero is a commitment for each worker to work hand in hand with Foreman Manhattan and subcontractors to accomplish these goals. The safety of workers on our sites is very important and we want every worker to return home to their family uninjured at the end of each day.

PAYMENT PROCEDURES

A. Description of Work

1. Submit Applications for Payment to Construction Manager in accord with the schedule established in the Agreement for Construction between the Construction Manager and the Contractor.
2. Related requirements in other parts of the project manual:
 - a) Lump Sum and Unit Prices: Agreement between Construction Manager and Contractor.
 - b) Progress Payment, Retainage and Final Payment: Conditions of the Contract.

B. Related Work Specified Elsewhere

1. Values

Prior to submitting the first application for payment, the Contractor shall submit to the Construction Manager a schedule of values in accordance with the general conditions and supplementary conditions. The schedule shall be supported by a detailed breakdown of costs for each value, which shall be in a form with blanks to show total value, previous estimated value of work completed, and value of work completed on this estimate. The breakdown shall include percentages of completion or units completed as appropriate. The Construction Manager shall examine the schedule and breakdown and make objections, if any. Prior to submitting the first application for payment, the Contractor shall resolve all objections of the Construction Manager to the schedule of values and breakdown.

2. Form of Application

The application for payment shall be submitted typewritten on AIA Document G702 and G703. Attachments to the application for payment shall be the following:

- a) Stored Materials Invoice Tabulation Sheet.
- b) Invoices for Stored Materials.
- c) Contractor's Affidavit.

C. Preparation of Application for Each Progress Payment

1. Application Form (AIA G702):

- a) Fill in required information, including that for change orders executed prior to the date of submittal of application.
- b) Fill in summary of dollar values to agree with the respective totals indicated on the continuation sheets.
- c) Execute certification with the signature of a responsible officer of the contract firm.

2. Continuation Sheets (AIA G703):

- a) Fill in total list of all scheduled component items of work, with item number and the scheduled dollar value for each item.
- b) Fill in the dollar value in each column for each scheduled line item when work has been performed. Round off values to nearest dollar.
- c) List each change order executed prior to the date of submission, at the end of the continuation sheets. List by change order number, and description, as for an original component item of work.

3. Invoices for materials stored at or near the site (in accordance with the Agreement and Supplemental Conditions) must be presented with the application for payment for materials. Invoices shall be accompanied by an attached itemized statement (tabulation) giving the following information:
 - a) Invoice number and date, name of invoice, description, and corresponding item in schedule of values.
 - b) Pay application on which first entered.
 - c) Total amount of invoice.
 - d) Value of the materials invoiced which were placed in the work as reflected on previous pay application.
 - e) Value of the materials invoiced which were placed in the work as reflected on this pay application.

D. PREPARATION OF APPLICATION FOR FINAL PAYMENT

1. Fill in application form as specified for progress payments.
2. Use continuation sheet for presenting the final statement of accounting as specified in Section 01770 - Contract Closeout.

E. SUBMITTAL PROCEDURE

1. Submit Applications for Payment to Construction Manger no later than the 20th of each month. Work performed from the 20th of the previous month and the 20th of the current month shall be included in each months billings.
2. Number: One (1) copy of each application, affidavit, and invoices, invoice tabulation.
3. When Construction Manager finds the application properly completed and correct, he will transmit a certificate for payment to Owner.

SHOP DRAWINGS, PRODUCT DATA and SAMPLES

PART I – GENERAL

A. Description of Work

1. Submit shop drawings, product data and samples required by the Contract Documents.
2. Designate in the construction schedule, or in a separate coordinated schedule, the dates for submission and the dates that reviewed shop drawings, product data and samples will be needed.

B. Related Requirements

1. Agreement for Construction: Definitions, and Additional Responsibilities of Parties.
2. Division 1: Schedules, Submittals, Tests and Approvals.
3. Division 1: Project Record Documents.
4. Designate in the construction schedule, or in a separate coordinated schedule, the dates for submission and the dates that reviewed shop drawings, product data and samples will be needed.

C. Shop Drawings

1. Drawings shall be presented in a clear and thorough manner.
2. Details shall be identified by reference to sheet and detail, schedule or room numbers shown on Contract Drawings.

D. Product Data

1. Preparation:
 - a. Clearly mark each copy to identify pertinent products or models.
 - b. Show performance characteristics and capacities.
 - c. Show dimensions and clearances required.
 - d. Show wiring or piping diagrams and controls.
2. Manufacturer's standard schematic drawings and diagrams:
 - a. Modify drawings and diagrams to delete information which is not applicable to the Work.
 - b. Supplement standard information to provide information specifically applicable to the Work.

E. Samples

1. Office samples shall be of sufficient size and quantity to clearly illustrate:
 - Functional characteristics of the product, with integrally related parts and attachment devices.
 - Full range of color, texture and pattern.
2. Field samples and mock-ups:
 - Contractor shall erect, at the project site, at a location acceptable to the Construction Manager.
 - Size or area: That specified in the respective specification section.
 - Fabricate each sample and mock-up complete and finished.
 - Remove mock-ups at conclusion of Work or when acceptable to Construction Manager and Owner's Representative.

F. Contractor / Subcontractor Responsibilities

1. Review shop drawings, product data and samples prior to submission.
2. Determine and verify:
 - Field measurements.
 - Field construction criteria.
 - Catalog numbers and similar data.
 - Conformance with specifications.
3. Coordinate each submittal with requirements of the Work and of the Contract Documents.
4. Notify the Architect/Engineer and Construction Manager in writing, at time of submission, of any deviations in the submittals from requirements of the Contract Documents.
5. Begin no fabrication or work which requires submittals until return of submittals with Architect/Engineer approval.
6. Contractor's Certification:

The Contractor shall affix to each submittal drawing sheet, product booklet, and sample transmittal sheet, a stamp certifying that he has carried out in full his responsibilities regarding submittals. The stamp shall be signed and dated by the Contractor's authorized personnel. The Architect/Engineer will not review or accept submittals which do not conform to this requirement. The stamp shall contain the following information and certification:

Name of Project & Contract Number

Contractor's Project Number

Architect/Engineer's Project Number

Submittal Number

Drawing Reference _____

Specification Section Reference _____

CONTRACTOR'S CERTIFICATION:

Contractor has determined or verified all quantities, dimensions, field construction criteria, materials, catalog numbers, and similar data, and has coordinated the information within the submittal with the requirements of the Contract Documents, and assumes full responsibility for so doing.

Name of Contractor

By _____ Date _____

G. Submittal Requirements and Procedures

1. All shop drawings and submittals will be submitted by the Subcontractor / Material Supplier directly to Foreman Manhattan in accordance with Contract General and Supplementary conditions, specification sections 01 3300 Submittals, 01 6000 Product Requirements and others as they apply.
2. The Subcontractor/Supplier has the responsibility of insuring timely submissions and must indicate those on which prompt approvals are critically needed. Allow a minimum of four (4) full weeks, after receipt by Foreman Manhattan, for the submittal review process. This time frame, plus the time required for the fabrication and delivery compared to the start date on the project schedule, will give you the latest submittal requirement date.
3. As a member of the project team, you are responsible to assist Foreman Manhattan in coordinating your work with other trades. It is imperative you identify, on each shop drawing, exactly what information must be received or work completed by others in order to maintain the project schedule.
4. All Subcontractors/Suppliers will be required to maintain scheduled delivery of materials on submittals which must be revised and resubmitted, or which were rejected due to non-compliance with Contract Documents.

G. Submittal Requirements and Procedures Cont'd

5. Each submittal, drawing, certificate of compliance, equipment list, etc. shall be identified with the following information as applicable:
 - A complete index of shop drawings and product data sheets contained in the submittal packet.
 - An 8 in. x 8 in. blank space for Contractor, Architect/Engineer, and Owner stamps.
 - Date and revision dates
 - Project Title
 - Name of :
 - Owner
 - Architect
 - Contractor – Foreman Manhattan Construction Team
 - Subcontractor
 - Suppliers
 - Manufacturer
 - Identification of product or material specifically indicated
 - Identification of deviations from Contract Documents.
 - Identification of revisions on resubmittals.
 - Relation to adjacent structure or materials
 - Field dimensions, clearly identified as such
 - Reference specification section or applicable paragraphs
 - Applicable standards, such as ASTM No., etc.
6. Make submittals promptly in accordance with approved schedule, and in such sequence as to cause no delay in the work or in the work of any other contractor.
7. All submittals must be uploaded via the Foreman Manhattan Planroom Drop Box as complete packages and labeled appropriately (i.e. 03 3000 Cast-In-Place Concrete). Piecemealed submittals will be rejected. The submittal register will be made available as for reference. However, it is incumbent upon the Subcontractor/Supplier to review the contract documents for all submittal requirements. All Subcontractors/Suppliers will be required to submit submittal packages within thirty (30) days of a signed subcontract.
8. Shop drawings, product data, certificates of compliance, certified test results, samples, equipment lists and mechanical layout drawings, spare parts lists, operation and maintenance manuals, electrical diagrams, welder certifications, engineering calculations etc. must be submitted in accordance with Contract Specifications and the following procedures:
9. All submittals must be made in a timely and sequential manner consistent with good construction practice to allow time for review, action and dissemination of submittal information prior to purchase and/or installation of material or equipment. The submittal time will be in accordance with the requirements of the Project Schedule.
10. Transmittal or Cover letter - Identify on the transmittal letter the project name, subcontractor or supplier, pertinent drawing sheets, detail numbers and appropriate specification sections. List all submittal register items in the submittal package. Identify all deviations in the submittals from required in the Contract Documents.

G. Submittal Requirements and Procedures Cont'd

11. The Subcontractor/Supplier is not relieved of responsibility for any deviation from the requirements of the Contract Documents by the Architect's approval of the shop drawings, product data, or samples unless the Subcontractor has specifically informed the Architect in writing of such deviation at the time of submission and the Architect has given written approval to the specific deviation. The Subcontractor is not relieved from responsibility for errors or omissions in the shop drawings, product data, or samples by the Architect's approval. The checking for the accuracy of the shop drawings is the Subcontractor's responsibility. By reviewing and submitting shop drawings, product data, and samples, the Subcontractor represents that they have determined and verified all materials, field measurements, and field construction criteria related thereto, or will do so and that the Subcontractor has checked and coordinated the information contained within such submittals with the requirements of the work and of the Contract Documents.
12. No Product Substitutions allowed. All product changes need to be submitted as formal design changes.
13. All deviations from the Contract Documents must be identified in writing noting the reason for deviations and shall be indicated and clouded for attention on your transmittal and submittal respectively. Only those deviations so noted will be considered for approval.
14. The approval and/or acceptance of items presented as "equal," that are later identified as of lesser value or inferior quality, will not preclude rejection of said item upon discovery by Foreman Manhattan, the Architect/Engineer or Owner.

H. Resubmission Requirements

1. Make corrections or changes in the submittals required by the Architect/Engineer and Owner and resubmit until approved.
2. Shop Drawings and Product Data:
 - Revise initial drawings or data, and resubmit as specified for the initial submittal.
 - Indicate changes which have been made other than those requested by the Architect/Engineer and Owner.
 - Provide index showing which drawings contain revisions or have been replaced with new drawings and which are resubmitted without revisions.
3. Samples: Submit new samples as required for initial submittal

I. Distribution

1. Distribute reproductions or shop drawings and copies of product data which carry the Architect/Engineer and Owner stamp to:
 - Job site file.
 - Record documents file.
 - Other affected contractors.
 - Subcontractors.
 - Supplier or fabricator.

J. Architect/Engineer Duties

1. Affix stamp and initials or signature, and indicate status.
2. Transmit approved submittals to Owner for review and approval and receive from Owner for return to Contractor.
3. Return submittals to Construction Manager for distribution, or for resubmission.

K. Owner Duties

1. Affix stamp and initials or signature, and indicate status.
2. Return submittals to Architect/Engineer for transmittal to Contractor.