



CGA Engineers, Inc.

Civil / Environmental Engineering
8179 E 41st St. Tulsa, OK 74145
TEL (918) 749-5800 / FAX (918) 749-5858

July 25, 2018

Tina Jones
Cherokee Nation Entertainment
777 West Cherokee Street
Catoosa, OK 74015

RE: Cherokee Springs Plaza OG&E Substation Engineering Contract No. 11E0089.00, Service Agreement No. 11E0089.17 – Addendum No. 1

Dear Ms. Jones:

Attached is Addendum No. 1 for the above referenced project. Addendum No. 1 includes 2 items; Typical Section for Concrete Option and Additional Geotechnical Soils Report. The Geotechnical Report will be under separate attachment as the file is large. All other provisions of plans and specifications shall remain in full effect.

Sincerely,

CGA Engineers, Inc.
Dwain M. Garner
President



07/25/2018

Attachments – as noted

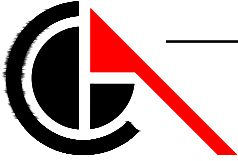

CGA Engineers, Inc.

Civil / Environmental Engineering
8179 E 41st St. Tulsa, OK 74145
TEL (918) 749-5800 / FAX (918) 749-5858

July 25, 2018

**ADDENDUM NO. 1
TO
ROADWAY AND GRADING PLANS FOR
CHEROKEE NATION SPRINGS PLAZA OG&E SUBSTATION**

Addendum 1 consists of TWO (2) items as follows:

CLARIFICATIONS

- 1) Construction time for project is **300** Calendar Days. Regardless of how the suggested traffic control items were calculated, contractor shall use the **300** calendar days allocated for construction.

CONSTRUCTION DRAWINGS

- 1) **ADD** sheet Alt 1-Typical Section- Portland Cement Concrete Section.

ADDITIONAL DOCUMENTS AND SPECIFICATIONS

- 2) Additional Geotechnical Soils Report (Separate document).

All other provisions of the Plans and Specifications shall remain in full force and effect.

Dwain Garner, P.E.
Engineering Manager



7/25/2018

Attachments:
Typical Section Plan Sheet
Geotechnical Soils Report

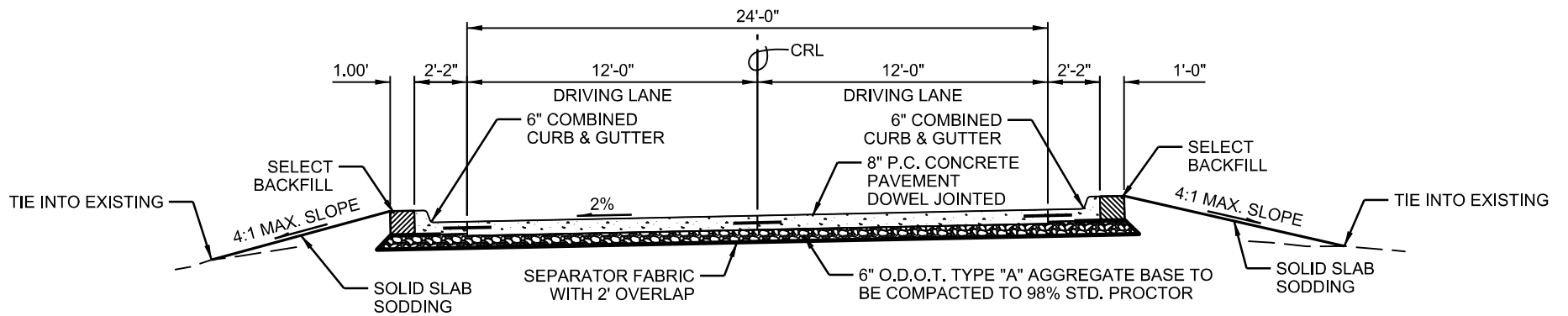

ADD ALT. - P.C. CONCRETE TYPICAL SECTION

STA. 10+69.30 TO STA. 18+18.79

DATE: 07/2018	SCALE: N/A
FILE NO.: 18-59-005-07	SHEET: ALT 1
SURVEY BY: GARY GILL	DRAWN BY: SCB
	CIVIL/ENVIRONMENTAL ENGINEERING 8179 East, 41st Street, TULSA, OKLAHOMA 74145
	PHONE: (918) 749-5800 FAX: (918) 749-5858 C.A. NO.: 1371 - EXPIRES: 6/30/20

<h1>TYPICAL SECTION</h1>
<h2>OG&E SUBSTATION AT CHEROKEE SPRINGS PLAZA</h2>
FILE: P:2018/18-59-007-05/DESIGN/SHTS/G-OGE-SUB-RoadwayPnP

ALT 1