



BID PACKAGE 02 – ADDENDUM 06

Date: April 22, 2020

Re: Wilma P Mankiller Health Center Expansion

From: James R Childers Architect, Inc.
45 South 4th Street
Fort Smith, Arkansas 72901

04-22-20



This addendum forms part of the Contract Documents, and modifies the documents as noted below. Acknowledge receipt of this addendum in the space provided on the bid form. Failure to do so may subject the bidder to disqualification.

Item 01 See attached Substitution Request for Operable Partition.

Item 02 See Prebid Questions and Responses attached.



SUBSTITUTION REQUEST (After the Bidding Phase)

Project: Wilma P Mankiller Clinic
Substitution Request Number: 01
From: Ryan Mitchell - Burgess Company
To: Chad Bell - M. Ross Construction
Date: 4-22-20
Re: Moderco Operable Partition
A/E Project Number: 18-01.01
Contract For:

Specification Title: 102238 - Operable Partition
Description:
Section:
Page:
Article/Paragraph:

Proposed Substitution: Moderco, Inc. - 115 de lauzon, Boucherville, QC Canada, J4B 1E7
Manufacturer Address:
Phone: 450-641-3150
Trade Name: Acoustically Rated Operable Partitions
Model No.: Signature 842
Installer: Burgess Co.
Address: 11711 S. Portland Ave, OKC, OK 73170
Phone 405-760-4236

History: [] New product [] 2-5 years old [X] 5-10 years old [X] More than 10 years old

Differences between proposed substitution and specified product: Piano hinges projecting 1/4" from panel face

X [] Point-by-point comparative data attached

Reason for not providing specified item: Burgess Co. is a dealer and certified installer for Moderco in the State of Oklahoma.

Similar Installation:
Project: Falls Creek Conference Center Architect: Michael McCoy Architects
Address: 6714 OK-77D
Owner: Baptist General Convention of Oklahoma
Davis, OK 73030
Date Installed: April 2016

Proposed substitution affects other parts of Work: X [X] No [] Yes; explain

Savings to Owner for accepting substitution: TBD (\$ TBD).

Proposed substitution changes Contract Time: [X] No [] Yes [Add] [Deduct] days.

Supporting Data Attached: [X] Drawings [X] Product Data [] Samples [] Tests [] Reports []

SUBSTITUTION REQUEST (Continued)

The Undersigned certifies:

- Proposed substitution has been fully investigated and determined to be equal or superior in all respects to specified product.
- Same warranty will be furnished for proposed substitution as for specified product.
- Same maintenance service and source of replacement parts, as applicable, is available.
- Proposed substitution will have no adverse effect on other trades and will not affect or delay progress schedule.
- Cost data as stated above is complete. Claims for additional costs related to accepted substitution which may subsequently become apparent are to be waived.
- Proposed substitution does not affect dimensions and functional clearances.
- Payment will be made for changes to building design, including A/E design, detailing, and construction costs caused by the substitution.
- Coordination, installation, and changes in the Work as necessary for accepted substitution will be complete in all respects.

Submitted by: Ryan Mitchell - Sales Manager

Signed by: _____

Firm: Burgess Building Company, LLC.

Address: 11711 S. Portland Ave
Oklahoma City, OK 73170

Telephone: 405-898-0955

Attachments: _____

A/E's REVIEW AND ACTION

- Substitution approved - Make submittals in accordance with Specification Section 01330.
- Substitution approved as noted - Make submittals in accordance with Specification Section 01330.
- Substitution rejected - Use specified materials.
- Substitution Request received too late - Use specified materials.

Signed by: _____ Date: _____

Additional Comments: Contractor Subcontractor Supplier Manufacturer A/E _____

Contractor / Subcontractor to coordinate necessary opening / clearance requirements per manufacturer's recommendations.
Provide required adjustments for Architect's review and approval prior to installation.

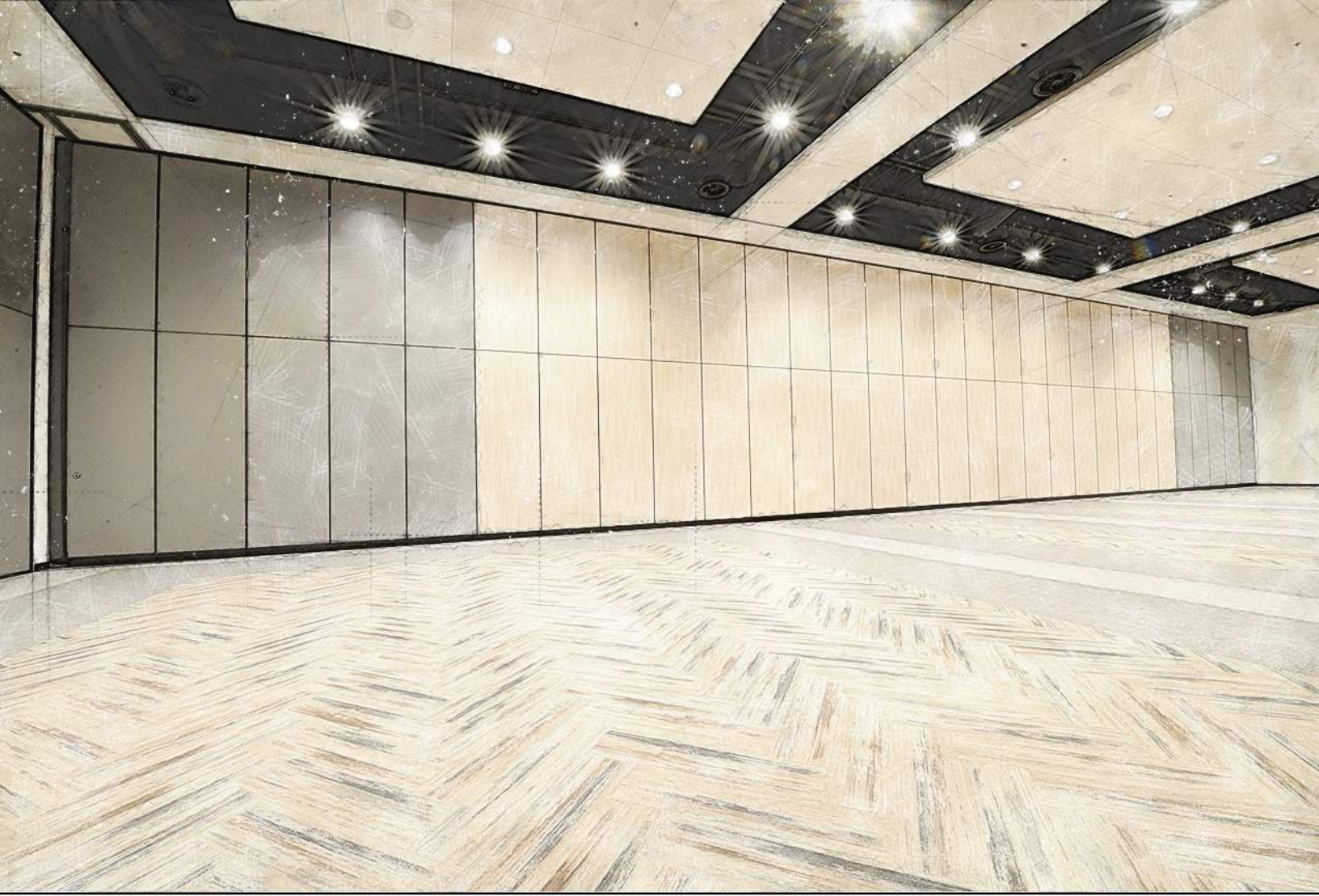

SIGNATURE 800 • OPERABLE PARTITION

SIGNATURE 800

OPERABLE PARTITION

BUILT TO LAST

Durability is the basis of the Signature design. All Signature Panels are built with a strong steel reinforced aluminum alloy frame that provides strength and stability as well as protection to the panel finish while panels are in motion.

LIMITLESS FINISH POSSIBILITIES

Traditional vinyl, fabric, and acoustical wallcoverings are available in a variety of colors and textures. The Signature offers far more including: Plastic Laminates, Wood veneers, & Specialty steels (to name a few). Our Installing Distributors will work with you on applied millwork moldings, inset trims and other custom design finishes.

SUSPENSION SYSTEMS

Aluminum tracks offer superior benefits including: yield strength stronger than steel, easy installation, and quiet smooth operation.

SEALS

Moderco's Standard Bottom (Floor) Seals are set automatically as the panels are placed into position. Automatic Seals do not require a removable handle to set or release the seal and can be used only when fully extending the Partition.

SINGLE PANELS

Single panel configurations allow the greatest flexibility in layouts. The panels can be used in openings of unlimited width and in multiple locations should the layout require flexibility.

PAIRED PANELS

Paired Panels are designed for straight line openings, stacking at one or both ends; they offer a quick, easy and practical set up. Paired Panels are two panels hinged together with a single carrier centered in each panel.

STORAGE POCKET DOORS

If the operable partition needs to be stored out of sight in a door closet or "Pocket" Moderco can supply a matching Pocket Door. The doors are generally used when the Operable Partition is sealing to the face of the Pocket Door.

PASS DOORS

Pass Doors may be incorporated in selected panels to provide egress, fire safety, service entrance or general access to an area. Signature Pass Doors all have mechanical retractable bottom seals, no sweeps dragging on the floor, and are constructed to match the panel.



MODELS	841	842	843-E	843-EP
OPERATION	Individual	Paired	Continuously hinged, electrically operated	Continuously hinged, electrically operated pneumatic seals
CONFIGURATION	Remote/Side	Center		
THICKNESS	4" (102mm)			
PANEL FRAME	Trimless and protective trim aluminum frame		Protective trim aluminum frame	
STC	43, 47, 49, 52, 53*, 55**		43, 47, 49, 52	43, 47, 49, 52, 53
FINISH OPTIONS	Vinyl, Fabric, Carpet, Customer owned or specified material, Plastic laminate, Full height marker board, Tack board, Wood veneer, Steel, Uncovered			
MAX. HEIGHT	33'-3" (10130mm)	22'-3" (6780mm)		
PANEL WIDTH	Min. 24" (609mm) Max. 48 1/2" (1230mm)		Min.28" (711mm) Max. 48 1/2" (1230mm)	Min.32" (813mm) Max. 48 1/2" (1230mm)
PANEL WEIGHT	6 to 9,5 lbs./sq. ft. (29 to 46 kg/sq.m)		6 to 8,5 lbs./sq. ft. (29 to 41,5 kg/sq.m)	6 to 9,5 lbs./sq. ft. (29 to 46 kg/sq.m)
CLOSURE	Telescopic panel or hinged closure panel		Side jamb, pocket door	Pneumatically-operated telescopic mechanism
SEALS	FA FM : 1; 1.5; 2; 2.5; 4; MM : 1; 1.5; 2; 2.5; 4; 55** AA : 1.5		FF	FP
TRACK	#23-T, #33-T, #55-T, #72	#45-T, #55-T, #72	#55-T	#55-T

SEALS TYPE

FA	Fixed top 1" (25mm) and Automatic bottom 2" (50mm) floor clearance
FM-1	Fixed top 1" (25mm) and manually-operated bottom 1" (25mm) floor clearance
FM-1.5	Fixed top 1" (25mm) and manually-operated bottom 1 1/2" (38mm) floor clearance
FM-2	Fixed top 1" (25mm) and manually-operated bottom 2" (50mm) floor clearance
FM-2.5	Fixed top 1" (25mm) and manually-operated bottom 2 1/2" (64mm) floor clearance
FM-4	Fixed top 1" (25mm) and manually-operated bottom 4" (102mm) floor clearance
MM-1*	Manually-operated top 1" (25mm) and bottom 1" (25mm) floor clearance
MM-1.5	Manually-operated top 1" (25mm) and bottom 1 1/2" (38mm) floor clearance
MM-2	Manually-operated top 1" (25mm) and bottom 2" (50mm) floor clearance
MM-2.5	Manually-operated top 1" (25mm) and bottom 2 1/2" (64mm) floor clearance
MM-4	Manually-operated top 1" (25mm) and bottom 4" (102mm) floor clearance
MM-55**	Manually-operated top 1" (25mm) and bottom 1" (25mm) floor clearance with additional fixed top sweeps
AA-1.5	Automatic top 1" (25mm) and bottom 1 1/2" (38mm) floor clearance
FF	Fixed top 1" (25mm) and bottom 2" (50mm) floor clearance
FP	Fixed top 1" (25mm) and pneumatically-operated bottom 2" (50mm) floor clearance





Technical Data Sheet Signature 842

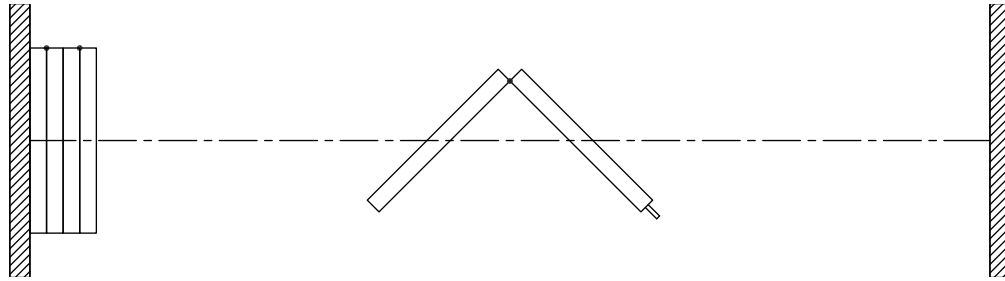

Features & Options

Standard Features

Manually-operated paired-panel movable partition.

STC 43 or 47 with gypsum board faces.

STC 49, 52, 53, or 55 with steel faces laminated to gypsum board.

102 mm [4"] nominal thickness. 1230 mm [48 1/2"] maximum width.

Clear-anodized steel-reinforced aluminum frame.

Protective trims on entire perimeter.

Combination aluminum and vinyl tongue and groove vertical sound seals between panels.

Final closure by telescopic jamb.

Type FA horizontal seals:

- Fixed top sweeps
- Automatic retractable bottom seals set as panels are deployed
- bottom seals provide a 50 mm [2"] floor clearance

(STC 53) Type MM-1 horizontal seals:

- top and bottom retractable seals
- Manually-operated, simultaneously-activated top and bottom seals
- bottom seals provide a 25 mm [1"] floor clearance

(STC 55) Type MM-55 horizontal seals:

- top and bottom retractable seals
- Manually-operated, simultaneously-activated top and bottom seals
- bottom seals provide a 25 mm [1"] floor clearance
- additional fixed top sweeps

Low profile steel hinges.

Clear-anodized 6063-T6 alloy aluminum track.

Each panel supported by one carrier made up of four vertically-aligned precision-ground hardened steel ball bearing wheels with nylon tires.

Vinyl wallcovering.

Optional Features and Accessories

STC 49, 52, 53, or 55 with gypsum board faces and steel backing.

Trimless vertical edges (STC 49 and over).

Powder-coated frame and/or track.

11 ga. steel track, painted white.

Upgraded wallcoverings: fabric, vertically-ribbed carpet, plastic laminate, full-height marker board, wood veneer, custom finishes.

Owner-supplied wallcovering (approval required).

Optional Features and Accessories (cont'd)

Final closure by hinged closure panel.

(STC 43 to 52) Type FM horizontal seals:

- Fixed top sweeps
- Manually-operated bottom seals
- bottom seals provide a floor clearance of 25 mm [1"], 38 mm [1 1/2"], 50 mm [2"], 64 mm [2 1/2"], or 102 mm [4"]

(STC 43 to 52) Type MM horizontal seals:

- top and bottom retractable seals
- Manually-operated, simultaneously-activated top and bottom seals
- bottom seals provide a floor clearance of 25 mm [1"], 38 mm [1 1/2"], 50 mm [2"], 64 mm [2 1/2"], or 102 mm [4"]

(STC 43 to 52) Type AA horizontal seals:

- top and bottom retractable seals
- simultaneously-activated Automatic top and bottom seals
- bottom seals provide a floor clearance of 38 mm [1 1/2"]
- simultaneous operation of telescopic closure and seals of last panel / last pair of panels (also available on partitions with type MM-1.5 horizontal seals)

ADA-compliant pass door with flush pulls and roller latch.

Door options:

- concealed automatic closer
- window frame
- door viewer
- panic bar
- panic bar with lockable lever
- self-luminescent exit sign with red (standard) or green (optional) faceplate *
- "running man" self-luminescent exit sign with green faceplate *
- deadbolt lock *

Inset white marker boards / chalk boards / natural cork tack boards.

Eraser boxes / chalk trays

Acoustical or non-acoustical pocket door.

UL/ULC-listed 1 hour fire-rating (requires type MM-1, MM-1.5, or MM-2 horizontal seals).

Horizontal Seals

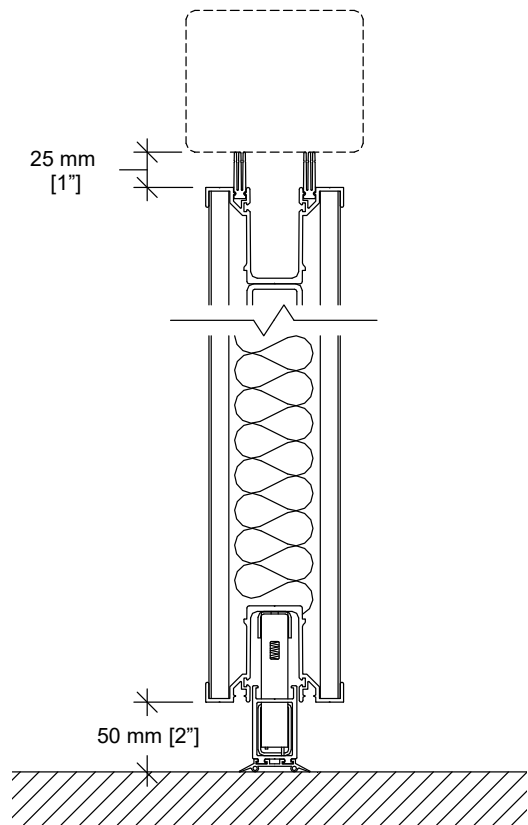

Floor clearance : 50 mm [2"]
Operating tolerances :
+0 mm / -38 mm [+0" / -1 1/2"]

Vertical Section

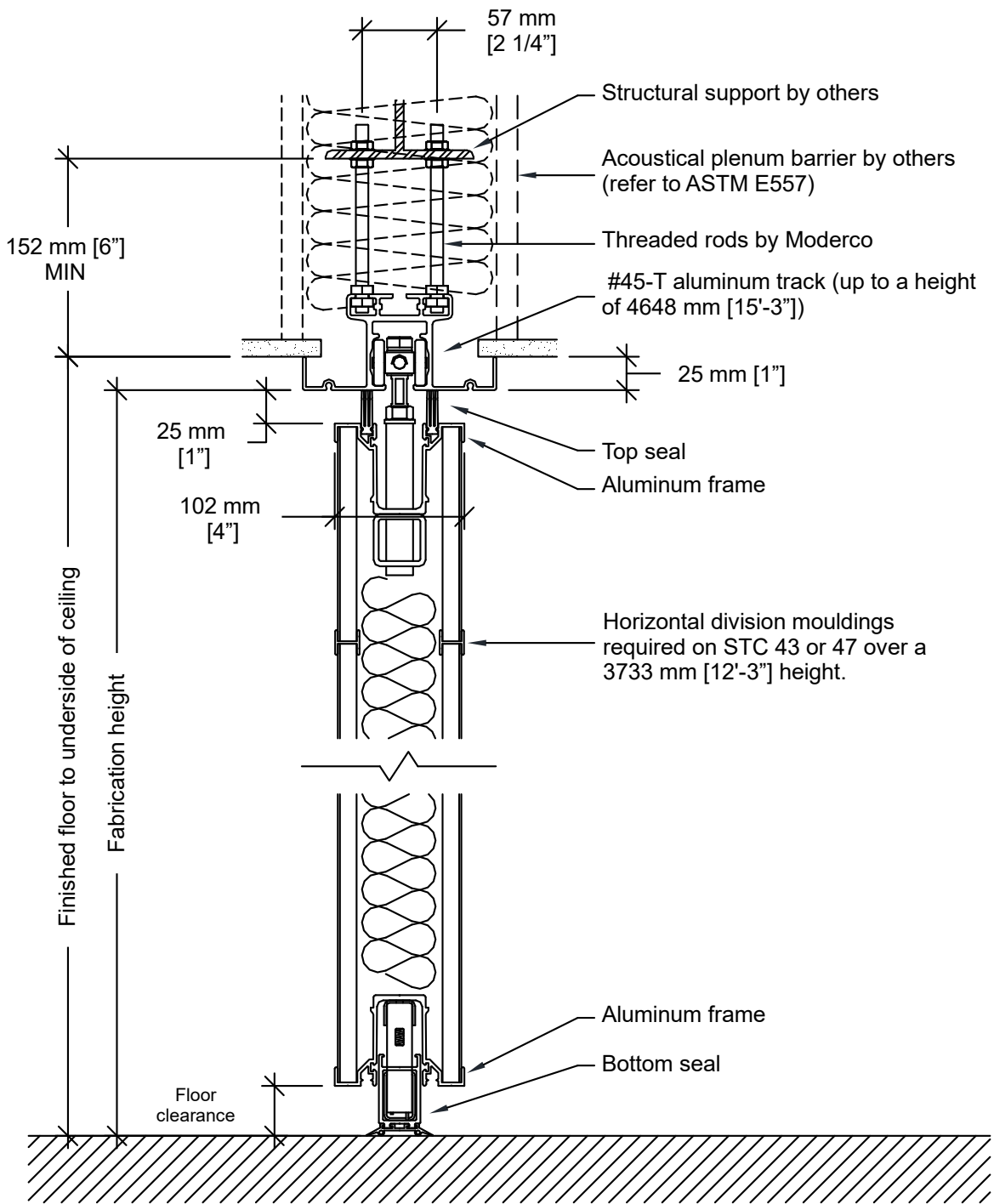

Plan Views

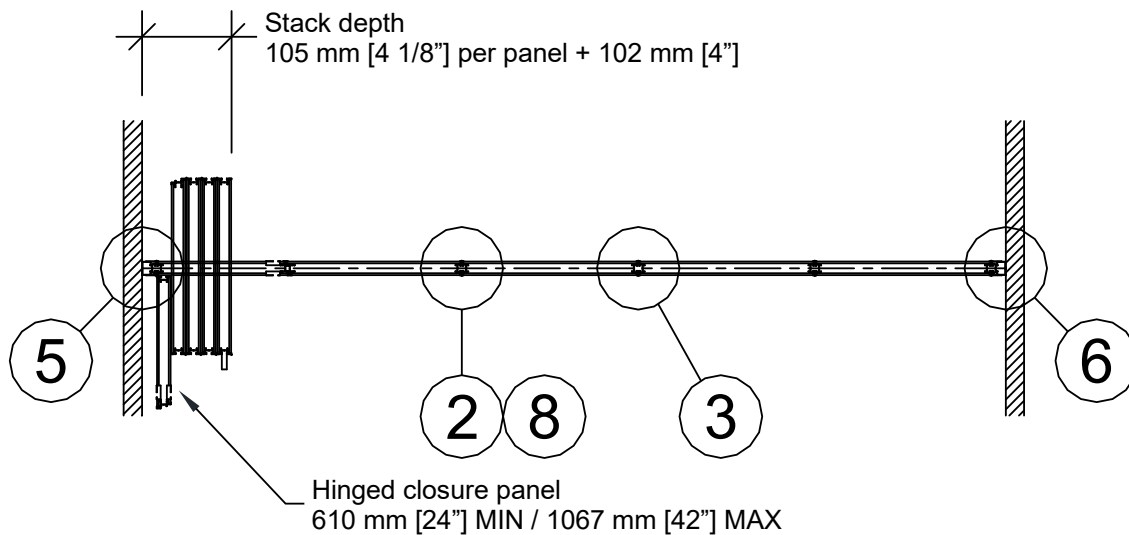
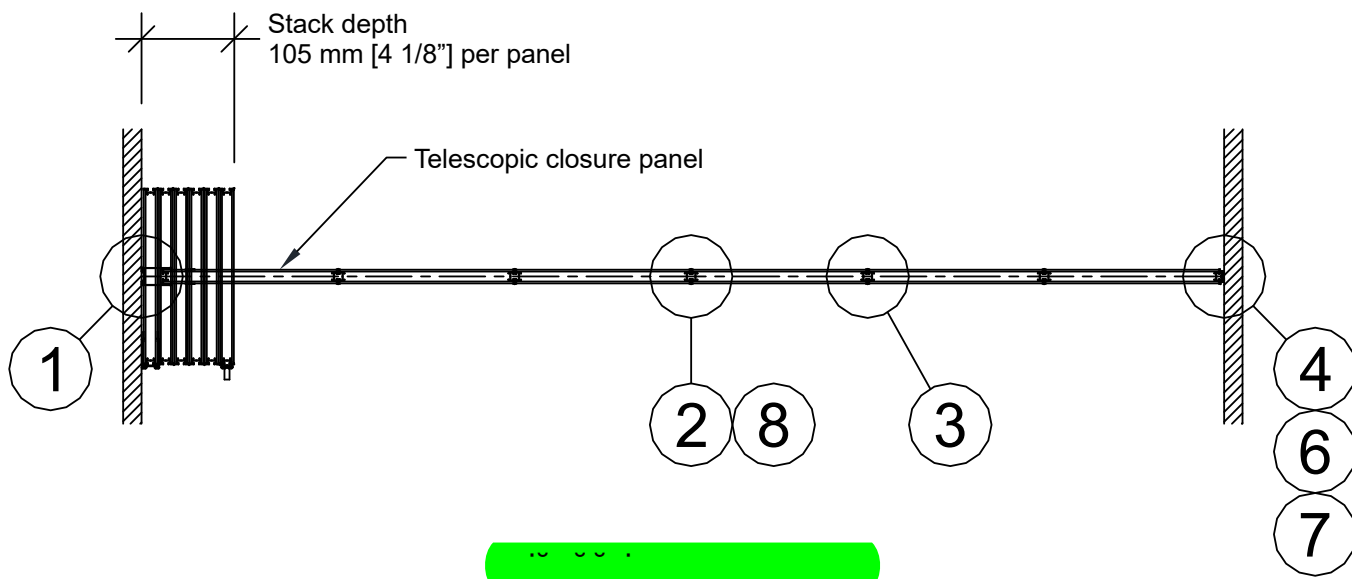

Horizontal Sections

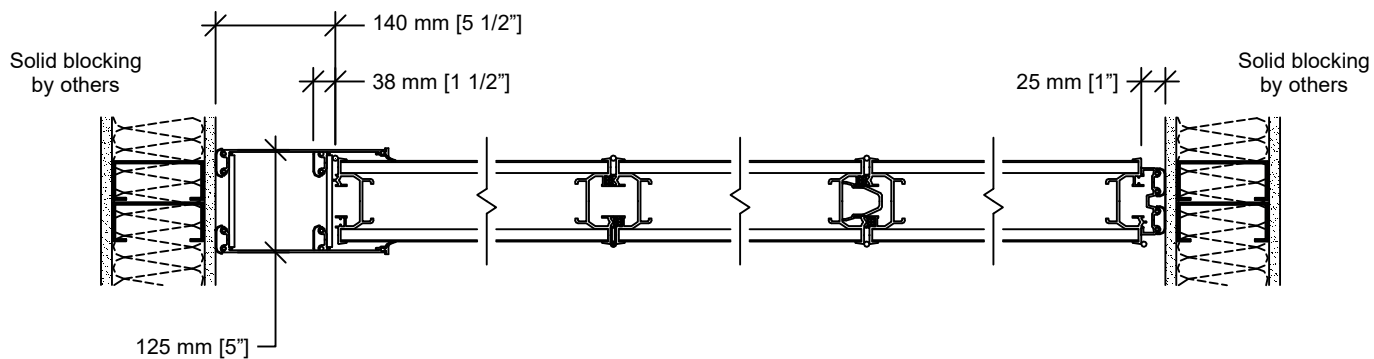

- ① Telescopic closure
- ② Hinged panel joint
- ③ Panel joint
- ④ Bulb seal

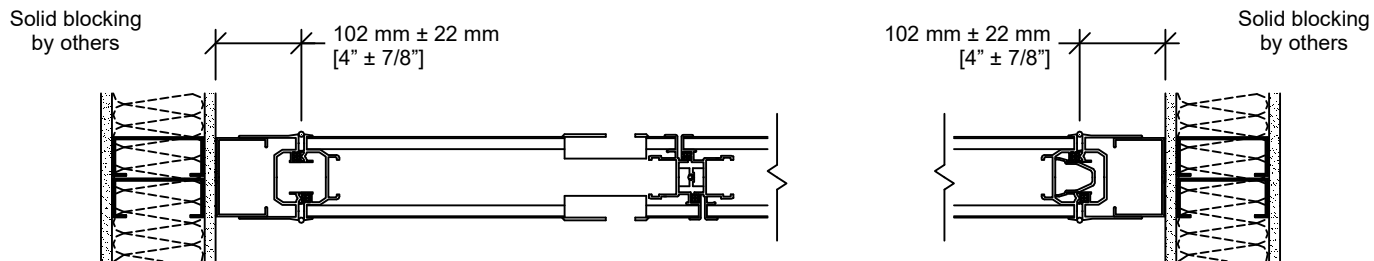

- ⑤ Hinged closure panel with recessed pulls and roller latch (optional)
- ⑥ Wall jamb (optional)

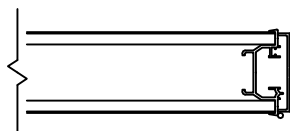

- ⑦ End cap (optional)

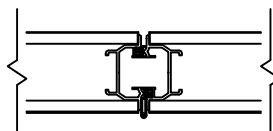

- ⑧ Panel joint with trimless vertical edges (optional) (STC 49 and over)

Typical Layouts

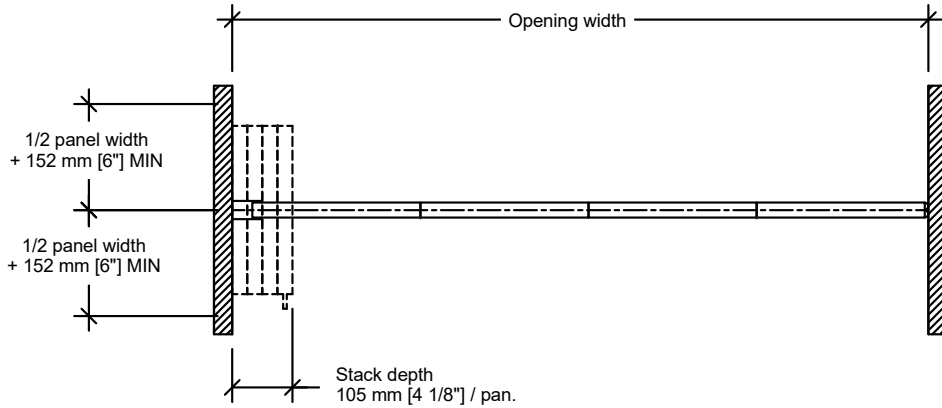

~ \$ ~ ~ ~ .

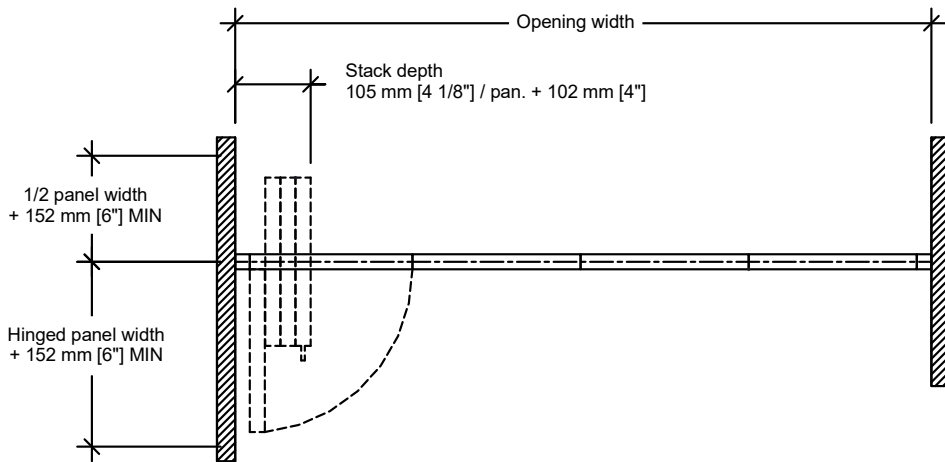

~ \$ ~ ~ ~ .

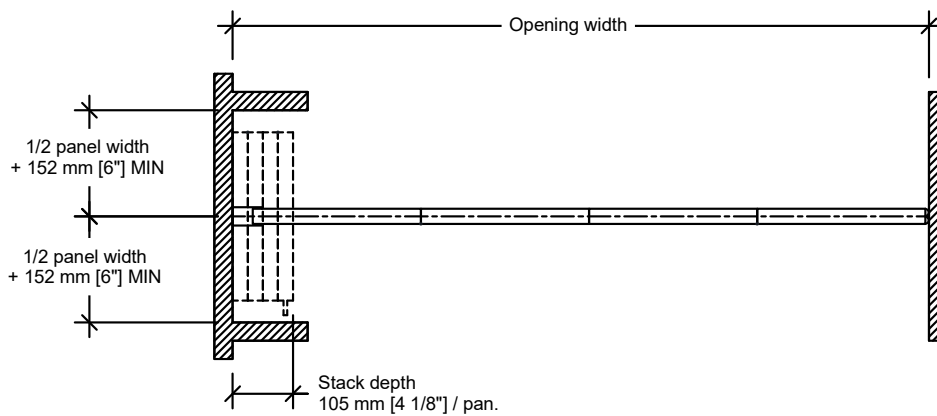

% ~ ~

MATÉRIAU	Acier 0.060" placage au zinc gris			
DURETÉ				
TRAITEMENT SPÉCIAL				
PROCÉDÉ	COUPE JET D'EAU	<input type="checkbox"/>	USINAGE	<input type="checkbox"/>
	COUPE LASER	<input type="checkbox"/>	PLIAGE	<input type="checkbox"/>
	COUPE PLASMA	<input type="checkbox"/>	EXTRUSION	<input type="checkbox"/>
	SOUDAGE	<input type="checkbox"/>	MOULAGE	<input type="checkbox"/>

Panel Hinge

RÉVISION			
No.	RÉVISION DESCRIPTION	DATE	INI.
6	Modifier dimension	2017-06-13	J.P
7	Ajout cotation et modifier présentation	2018-03-16	J.P

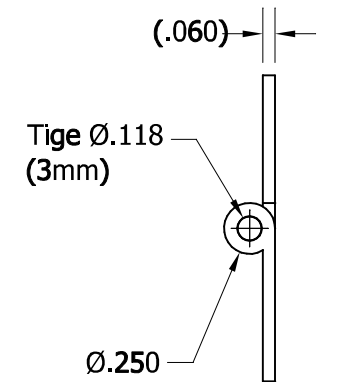
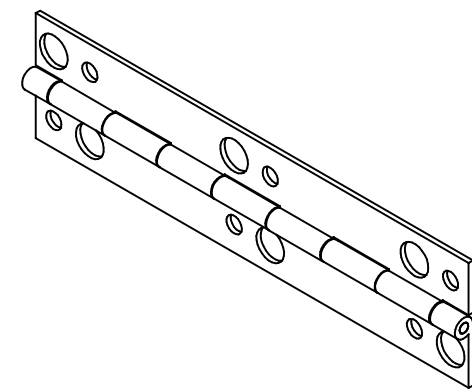
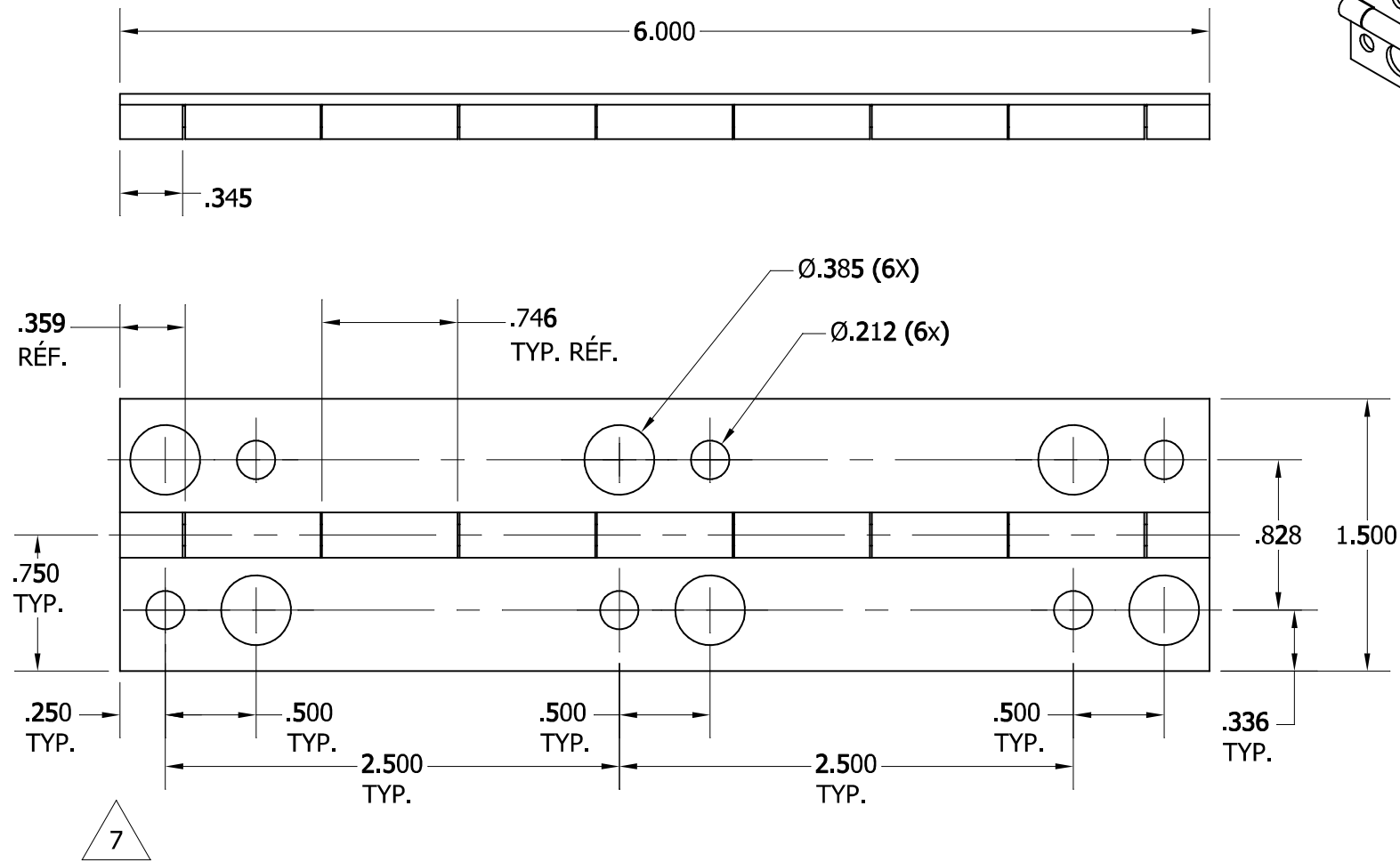

TOLERANCES GÉNÉRALES SI NON SPÉCIFIÉES		ÉCHELLE	1:1
PRÉCISION X.XXX	± 0.005	DATE	2016-02-19
PRÉCISION X.XX	± 0.010	CONÇU PAR:	denisl
PRÉCISION FRACTIONNAIRE	± 1/32	DESSINÉ PAR:	denisl
PRÉCISION ANGULAIRE	± 1°	VÉRIFIÉ PAR:	

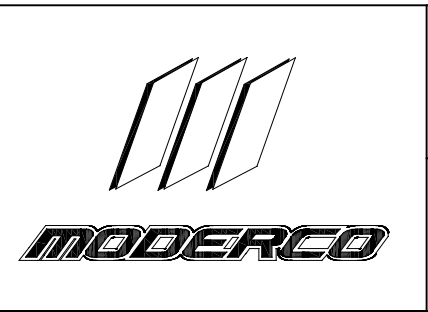

Charnière mur mobile		
PROJET INVENTOR: Librairie Modercoco		
MODERCO inc. 115, De Lauzon Boucherville, Québec J4B 1E7 Tél: (450) 641-3150 Fax: (450) 641-4965 Site web: www.moderco.com	1211-1191	R?V. 7

	Pre Bid-Questions:	Responses
1	Page 064023 - 14 Sect.H. Concealed backs and... .20 inch (5mm) thick. Architectural drawing 20/A8.31 a 1/2" back of solid backing. Lakewood specs call for 1/4" melamine MDF core which is closer to the .20 spec.	BACKING TO BE SOLID 1/2"
2	Page 12 3661 - 2 Sect. 2.2 Simulated Stone Countertop Materials. B. Panel thickness 1/2". Arch. drawing 05/A8.32 3/4" Solid Surfacing... . Lakewood uses 1/2" material which is the only size available.	SOLID SURFACE MATERIAL THICKNESS TO BE 1/2"
3	Page 06 4023 - 13 Sect. H. Kicks and Bases: Solid-hardwood lumber, 1 1/2. Arch. drawing 06/A8.32 shows a plywood base that looks like 3/4". Lakewood uses pressure treated 3/4" plywood.	PRESSURE TREATED PLYWOOD IS ACCEPTABLE
4	06 4023 - 13 Sect. F. Face Frames, Rails, Kicks and Bases: Solid-hardwood lumber or hardwood plywood, 3/4 in (19mm) thick minimum thickness. Arch. drawing 07/A8.32 shows no face frame. Lakewood specs are Frameless with out face frame.	FRAMELESS WITHOUT FACE FRAME IS ACCEPTABLE
5	Spec 102238-2.1 calls out manufacturers for "Ballrooms" and "Meeting Rooms". I am not seeing a ballroom on this project. The only operable partition detailed within the plans that I see is in Conference room 1-14-02. Can you confirm this is the only operable partition?	THAT IS THE ONLY OPERABLE PARTITION
6	Spec 102238-2.9 calls out electric operators. Is the operable partition to be electrically operated or manually operated? The partitions are to be manually operated	THE PARTITIONS ARE TO BE MANUALLY OPERATED
7	Spec 102238-2.10A calls out for a storage pocket door. A pocket door is not shown on the plans. A pocket door will require the pocket width to be increased more and also increased more in width. Is a pocket door required?	THERE IS NO POCKET DOOR REQUIRED
8	Spec 102238-2.10B calls for a pass thru door. A pass thru door is not shown on the plans. Is a pass thru door required? If so what location within the partition would it need to be located?	THERE IS NO PASS THROUGH DOOR REQUIRED