

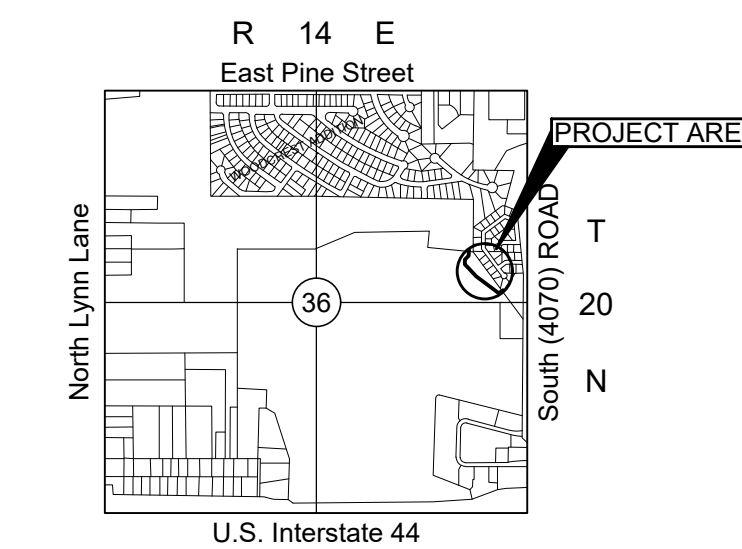

CHEROKEE NATION BUSINESSES

NEW PRIVATE 6" & 8" SANITARY SERVICE LINES NEW PRIVATE 6" WATER SERVICE LINE FOR ADMINISTRATION OFFICES

SE/4 SECTION 36, T-20-N, R-14-E, ROGERS COUNTY, OKLAHOMA

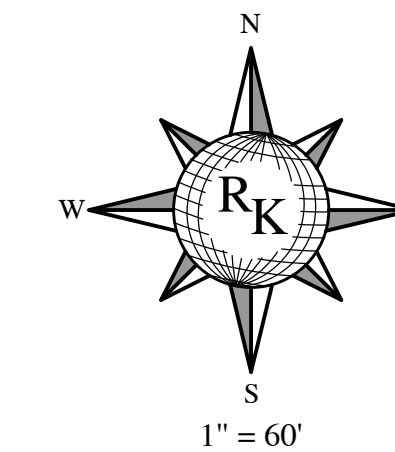

Location Map

Sheet Index

1	Cover Sheet
2	Notes & Details
3 & 4	Blow-up Plans
5	Sanitary Sewer Profiles

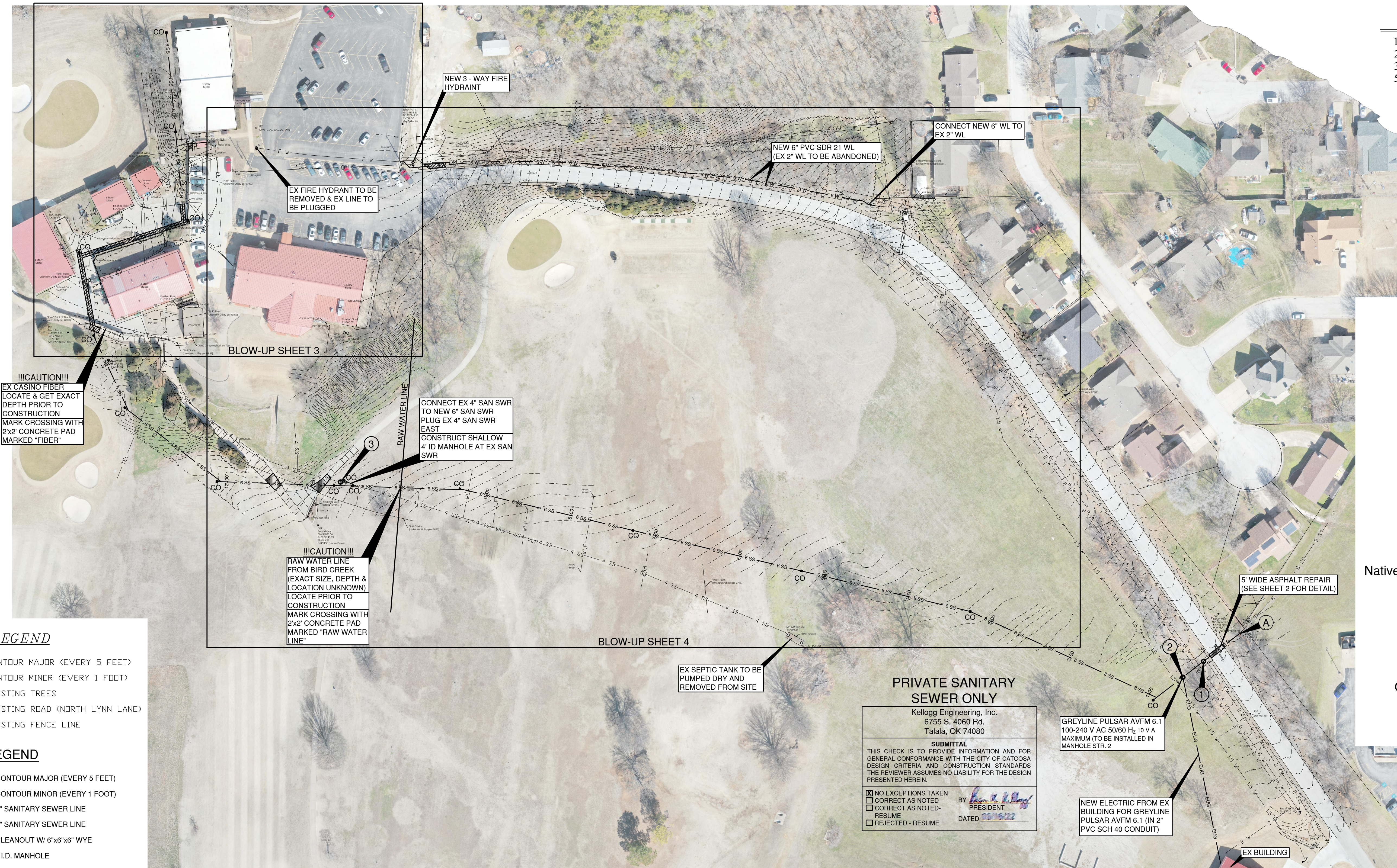

EXISTING LEGEND

- CONTOUR MAJOR (EVERY 5 FEET)
- CONTOUR MINOR (EVERY 1 FOOT)
- EXISTING TREES
- EXISTING ROAD (NORTH LYNN LANE)
- x — x — EXISTING FENCE LINE

PROPOSED LEGEND

- NEW CONTOUR MAJOR (EVERY 5 FEET)
- NEW CONTOUR MINOR (EVERY 1 FOOT)
- 6 SS — 6 SS — NEW 6" SANITARY SEWER LINE
- 8 SS — 8 SS — NEW 8" SANITARY SEWER LINE
- *CO — NEW CLEANOUT W/ 6"x6"x6" WYE
- — NEW 4' ID. MANHOLE
- _{LH} — NEW LAMP HOLE MANHOLE

PRIVATE SANITARY SEWER ONLY

Kellogg Engineering, Inc.
6755 S. 4060 Rd.
Tulala, OK 74080

SUBMITTAL

THIS CHECK IS TO PROVIDE INFORMATION AND FOR GENERAL CONFORMANCE WITH THE CITY OF CATOOSA DESIGN CRITERIA AND CONSTRUCTION STANDARDS. THE REVIEWER ASSUMES NO LIABILITY FOR THE DESIGN PRESENTED HEREIN.

- NO EXCEPTIONS TAKEN
- CORRECT AS NOTED
- CORRECT AS NOTED - RESUME
- REJECTED - RESUME

BY: *[Signature]*
PRESIDENT
DATED: 03/22/2023

BASIS OF BEARINGS

State Plane Coordinates
NAVD 1988

ENGINEER

RK & Associates, PLC
4815 South Harvard Ave. Ste. 290
Tulsa, Oklahoma 74135
Phone: (918) 277-4784
e-mail: rkosman@sbcglobal.net
Certificate of Authorization No. 4831
Expires June 30, 2021

SURVEYOR

Native Plains Surveying & Mapping, LLC
5807 South Garnett Road, Suite K
Tulsa, OK 74146
Certificate of Authorization No. 4916
Expires June 30, 2023

OWNER

Cherokee Nation Businesses
777 Cherokee Drive
Catoosa, OK 74135
Phone: (918) 384-7785

OWNER: Cherokee Nation Businesses (CNB)

REVISIONS

DATE

APPROVED

THIS DOCUMENT IS PRELIMINARY IN NATURE, AND IS NOT A FINAL SIGNED AND SEALED DOCUMENT.



RICHARD L. KOSMAN, PE. & ASSOCIATES, PLC
CIVIL ENGINEERING
4815 South Harvard Ave. Ste. 290
Tulsa, OK 74135
Phone: 918(277-4784)
Email: rkosman@sbcglobal.net
Certificate of Authority No. 4831
Expires June 30, 2023

THESE PLANS AND DRAWINGS MAY NOT BE REPRODUCED, CHANGED OR COPIED, IN ANY WAY UNLESS FIRST OBTAINING THE EXPRESS WRITTEN CONSENT OF RK & ASSOCIATES, NOR SHALL THEY BE ASSIGNED TO ANY THIRD PARTY UNLESS SAID WRITTEN CONSENT IS FIRST OBTAINED. ANY CHANGES MADE TO THESE PLANS WITHOUT THE CONSENT OF RK & ASSOCIATES SHALL RELIEVE RK & ASSOCIATES OF RESPONSIBILITY FOR ANY CONSEQUENCES RESULTING FROM SUCH CHANGES.

COVER SHEET

CHEROKEE NATION BUSINESSES (CNB)

SHEET 1 OF 5 02222 DATE: 03/22/2023



811 BEFORE YOU DIG...
1-800-522-4543
CALL OKIE

LOCATIONS OF UNDERGROUND UTILITIES WERE OBTAINED FROM THE UTILITY OWNERS. BEFORE DOING ANY WORK WITH HEAVY EQUIPMENT, THE CONTRACTOR SHALL NOTIFY THE UTILITY OWNERS OR "CALL OKIE (OKLAHOMA ONE-CALL)" NOT LESS THAN 48 HOURS IN ADVANCE AND SHALL ESTABLISH THE EXACT LOCATION AND DEPTH OF ALL UNDERGROUND UTILITIES.

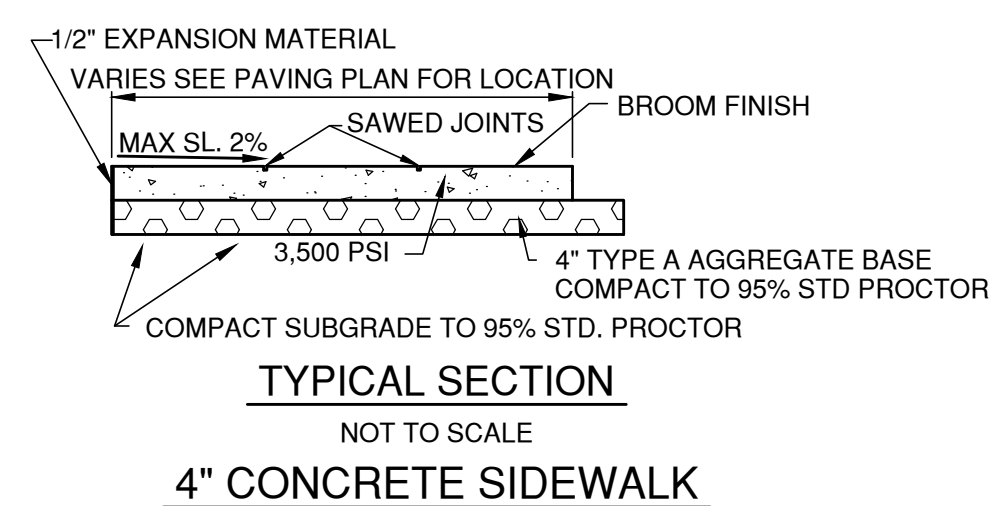

4" CONCRETE SIDEWALK
NOT TO SCALE

- COST FOR NEW CONCRETE SIDEWALK SHALL INCLUDE ALL SAWING, COMPACTION OF SUBGRADE TO 95% STD. PROCTOR AND TYPE "A" AGGREGATE BASE.
- CONTRACTOR TO PROVIDE 1/2" EXP. MAT'L. AT BUILDING.
- SEE STANDARD FOR RAMPS.
- USE SAME SECTION FOR MOTORCYCLE PARKING.
- 1/2" EXPANSION JOINTS ARE TO BE INSTALLED AT LEAST EVERY 25'. THEY SHALL ALSO BE INSTALLED BETWEEN THE NEW SIDEWALK AND (A) CURBS, (B) INTERSECTING SIDEWALKS AND DRIVEWAYS, (C) STEPS, (D) RETAINING WALLS, (E) FIXED OBJECTS.
- MAX. SLOPE 2%.
- CONTRACTOR TO LAYOUT SIDEWALK JOINTS & GET APPROVAL FROM OWNER & ENGINEER BEFORE SAW CUTTING BEGINS.
- SAW JOINTS SHALL 1" DEEP SHALL BE CUT AS SOON AS POSSIBLE AFTER MEDIUM BROOM FINISH WORK IS COMPLETE AND CONCRETE HAS CURED TO ACCEPT TYPE OF SAW EQUIPMENT.
- PROPORTION CONCRETE TO PRODUCE A STRENGTH OF 3,500 PSI AT 28 DAYS WITH MINIMUM CEMENT CONTENT OF 5 1/2 SACKS PER CU. YD. AND 5 TO 7 PERCENT ENTRAINED AIR, EXCEPT WHERE OTHERWISE INDICATED ON DRAWINGS.

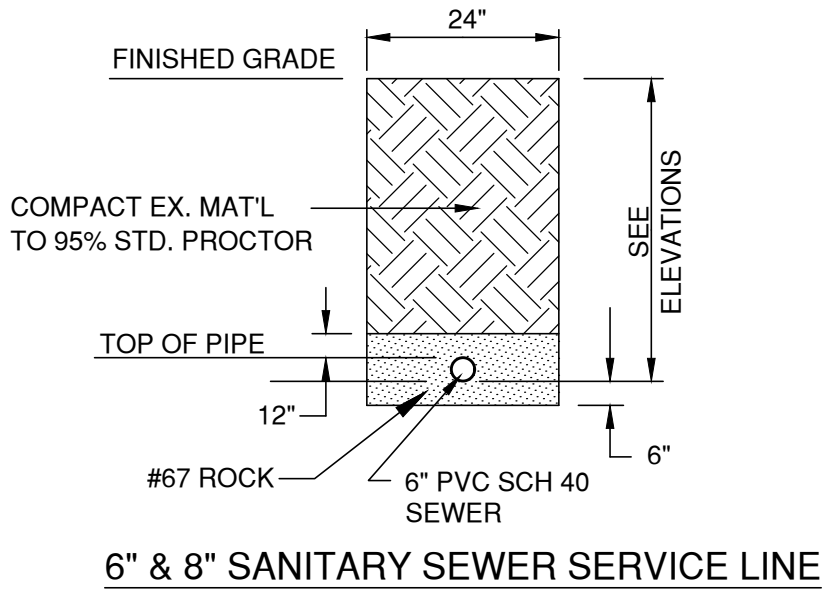

6" & 8" SANITARY SEWER SERVICE LINE TRENCH DETAIL NATURAL GROUND

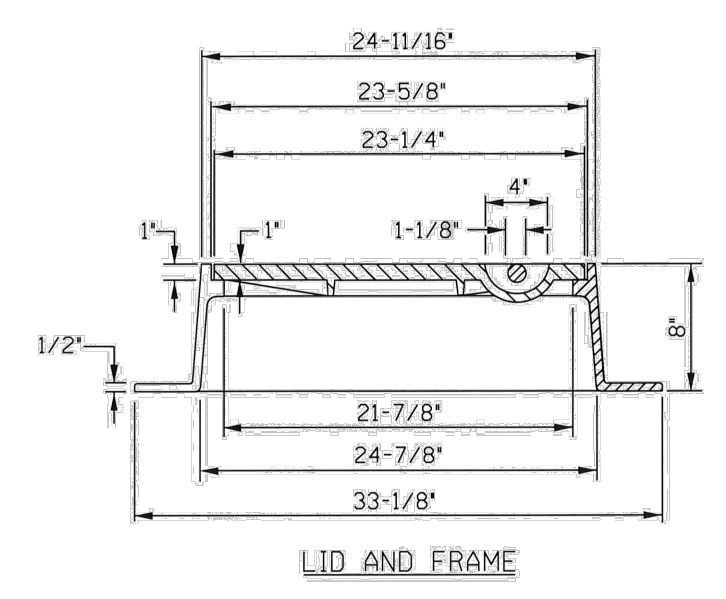

FRAME & LID DETAIL FOR 4' I.D. MH
SCALE: NONE

NOTE:
1. FURNISHED WITH MACHINED HORIZONTAL BEARING SURFACE.
2. BACK SIDE OF COVER READS: MADE IN USA AASHTO A48 358 JULIAN HEAT DATE

NOTE:
BOTTOM REINFORCEMENT CONFIGURATION MAY VARY ACCORDING TO MANUFACTURER, HOWEVER, ALL LIDS AND FRAMES SHALL CONFORM TO AND BE TESTED IN ACCORDANCE WITH THE STANDARD SPECIFICATION FOR GRAY IRON CASTINGS, ASTM A48, AND DRAINAGE STRUCTURE CASTINGS, AASHTO DESIGNATION: M306-89.

ALL LIDS AND FRAME SHALL MEET THE PROOF LOAD TEST AS SPECIFIED IN AASHTO DESIGNATION: M306-89, REPRESENTING A 2.5 SAFETY FACTOR OVER H-20 AND HS-20 LOADING.

- UTILITY NOTES:**
- THE LOCATION AND/OR ELEVATION OF EXISTING UTILITIES AS SHOWN ON THE PLANS IS BASED ON RECORDS OF THE VARIOUS UTILITY COMPANIES, AND WHERE POSSIBLE, MEASUREMENTS TAKEN IN THE FIELD. THE INFORMATION IS NOT TO BE RELIED ON AS BEING EXACT OR COMPLETE. THE CONTRACTOR MUST CONTACT THE APPROPRIATE UTILITY COMPANY AT LEAST 72 HOURS BEFORE ANY EXCAVATION TO REQUEST EXACT FIELD LOCATION OF EXISTING UTILITIES.
 - CONTRACTOR SHALL NOTIFY THE UTILITY AUTHORITIES BEFORE CONNECTING TO ANY EXISTING LINES. CONTRACTOR SHALL COORDINATE AND SCHEDULE TIE-INS/CONNECTIONS WITH ALL UTILITY COMPANIES/OWNERS.
 - ALL NECESSARY INSPECTIONS AND/OR CERTIFICATIONS REQUIRED BY CODES AND/OR UTILITY SERVICE COMPANIES SHALL BE PERFORMED PRIOR TO ANNOUNCED BUILDING POSSESSION AND THE FINAL CONNECTION OF SERVICE.
 - THE CONTRACTOR SHALL COORDINATE WITH THE APPROPRIATE UTILITY COMPANY PRIOR TO CONSTRUCTION, ADJUSTMENT, OR RELOCATION OF EXISTING UTILITIES AS DESIGNATED ON THE PLANS.
 - CONTRACTOR SHALL BE RESPONSIBLE FOR ALL CITY OF CATOOSA FEES.
 - CONTRACTOR SHALL PROVIDE ALL CONDUITS NECESSARY AS SHOWN ON THE PLANS. VERIFY LOCATION OF UTILITY TIE IN AND PROVIDE NYLON PULL CORDS INSIDE CONDUITS.
 - CONTRACTOR SHALL KEEP A DAILY AS-BUILT DRAWING ALONG WITH PICTURES OF ALL OF THE UNDERGROUND UTILITIES PRIOR TO BACKFILLING. PICTURES SHALL BE GIVEN TO ENGINEER, ARCHITECT AND OWNER'S REPRESENTATIVE ON A MONTHLY BASIS.

- SITE NOTES:**
- THE WORK AND MATERIAL SHALL COMPLY WITH ALL CITY/COUNTY/STATE FEDERAL REGULATIONS CODES AND OSHA STANDARDS.
 - CONTRACTOR SHALL ENSURE ALL NECESSARY PERMITS ARE OBTAINED PRIOR TO CONSTRUCTION START.

- GENERAL NOTES:**
- ALL PAVING CONSTRUCTION SHALL BE IN ACCORDANCE WITH THE OKLAHOMA DEPARTMENT OF TRANSPORTATION CURRENT STANDARD SPECIFICATIONS & STANDARDS.
 - CONTRACTOR SHALL GIVE THE NOTIFICATION CENTER OF THE OKLAHOMA 'ONE-CALL SYSTEM INC'. NOTICE OF ANY EXCAVATION NO SOONER THAN TEN DAYS OR LATER THAN 72 HOURS (EXCLUDING SATURDAYS, SUNDAYS OR LEGAL HOLIDAYS), PRIOR TO COMMENCEMENT OF WORK. PHONE 1-800-522-6543.
 - THE EXISTENCE AND LOCATION OF ANY UNDERGROUND UTILITY PIPES OR STRUCTURES SHOWN ON THESE DRAWINGS ARE OBTAINED BY A SEARCH OF THE AVAILABLE RECORDS. TO THE BEST OF OUR KNOWLEDGE, THERE ARE NO EXISTING UTILITIES EXCEPT AS SHOWN ON THESE DRAWINGS AND WE ASSUME NO RESPONSIBILITY AS TO THE ACCURACY OF THEIR DEPICTED LOCATION ON THESE DRAWINGS. THE CONTRACTOR IS REQUIRED TO TAKE DUE PRECAUTIONARY MEASURES TO PROTECT THE UTILITY LINES SHOWN, AND ALL OTHER LINES NOT OF RECORD OR NOT SHOWN ON THESE DRAWINGS BY VERIFICATION OF THEIR LOCATION IN THE FIELD PRIOR TO THE INITIATION OF THE ACTUAL PORTION OF THEIR WORK.
 - ALL CONSTRUCTION STAKING SHALL BE PERFORMED BY LICENSED SURVEYOR. ELECTRONIC DATA WILL BE MADE AVAILABLE TO THE SURVEYOR FOR HIS USE.
 - THE CONTRACTOR SHALL COMPLY WITH ALL APPLICABLE FEDERAL, STATE AND LOCAL LAWS GOVERNING SAFETY, HEALTH, AND SANITATION. THE CONTRACTOR SHALL PROVIDE ALL SAFEGUARDS, SAFETY DEVICES AND PROTECTIVE EQUIPMENT, AND TAKE ANY OTHER NEEDED ACTIONS ON HIS OWN RESPONSIBILITY OR AS THE ENGINEER MANY DETERMINE REASONABLY NECESSARY TO PROTECT PROPERTY IN CONNECTION WITH THE PERFORMANCE OF THE WORK COVERED BY THE CONTRACT. THE CONTRACTOR SHALL COMPLY WITH THE LATEST OSHA REGULATIONS.
 - ALL EXISTING TOPSOIL SHALL BE STRIPPED AND STOCKPILED IN AN AREA APPROVED BY THE OWNER.
 - ALL EXCESS MATERIAL SHALL BECOME THE PROPERTY OF AND BE DISPOSED OF BY THE CONTRACTOR IN A MANNER APPROVED BY THE OWNER.

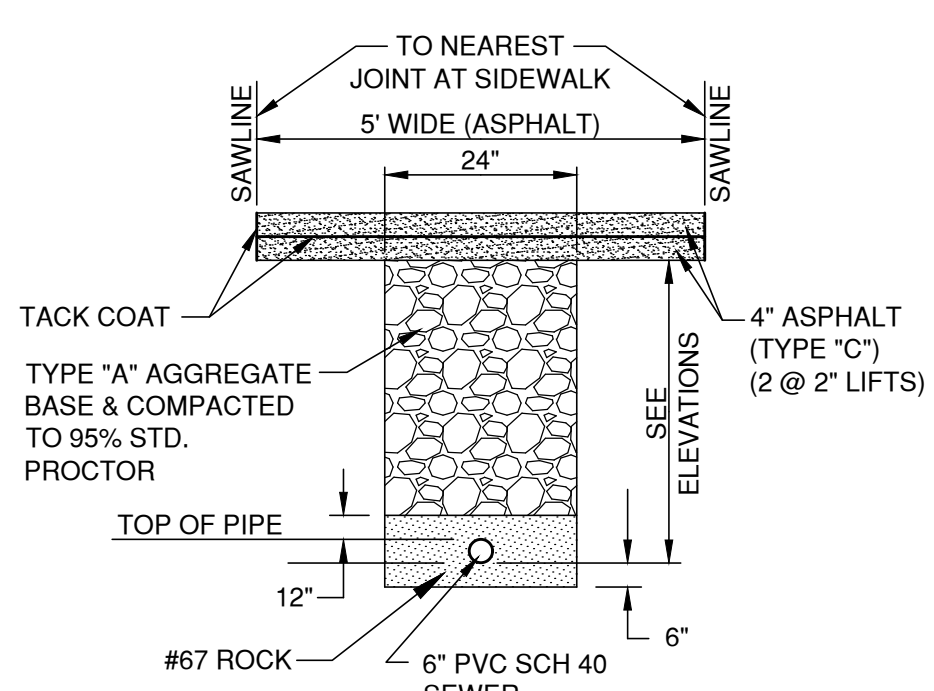

6" & 8" SANITARY SEWER SERVICE LINE & 6" WATER LINE TRENCH DETAIL UNDER PAVEMENT & SIDEWALK

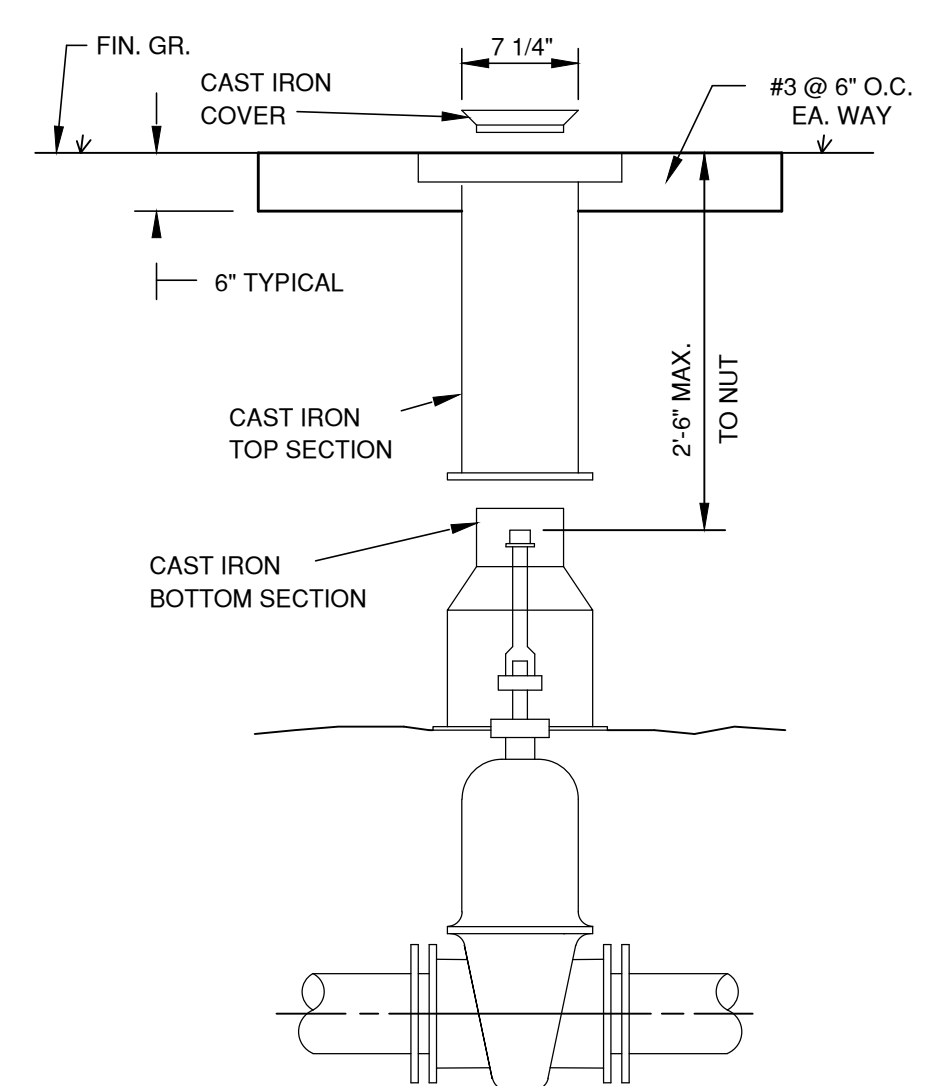

NORMAL INSTALLATION
NOTE: EXTENSION PIECE CAN BE CUT TO LENGTH REQUIRED WITH HANDSAW. POUR CONCRETE 2'-6" SQUARE AROUND TOP OF ALL VALVE BOXES.

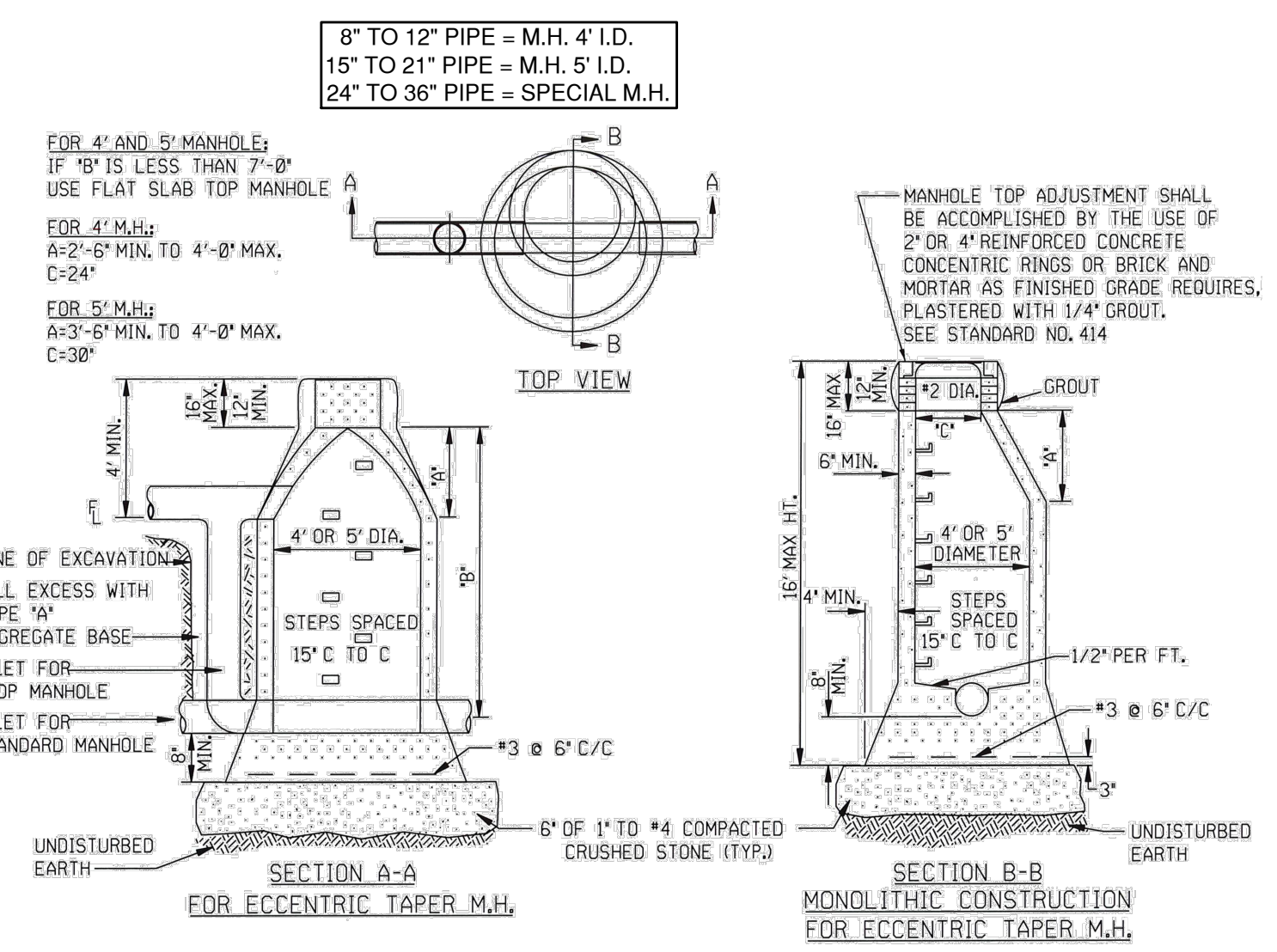

NOTE:

- CAST IN PLACE MANHOLES SHALL HAVE ECCENTRIC ENTRANCES AND SHALL BE EITHER THE FLAT SLAB OR ECCENTRIC TAPER TYPE SUBJECT TO THE SPECIFIED RESTRICTIONS.
- STEP DETAILS SHALL BE AS SHOWN ON THE STANDARD DETAIL FOR MANHOLE STEPS (STANDARD NO. 314).
- LOW SLUMP CONCRETE SHALL BE PLACED IN THE FOOTINGS AND LOWER WALLS AND SHALL BE PLACED AND VIBRATED IN ONE FOOT LIFTS.
- AN INSPECTOR MUST BE PRESENT BEFORE AND DURING THE PLACEMENT OF THE CONCRETE.
- THIS MANHOLE SHALL NOT BE USED IN PAVED STREETS OR OTHER TRAVELED AREAS.
- THE CONCRETE MUST SET FOR 48 HOURS BEFORE PIPE INSIDE OF MANHOLE IS TRIMMED.
- (ALTERNATE 3) INVERT MUST BE FORMED AT TIME OF BOTTOM POUR.
- WATER STOPS MAY BE ELIMINATED IF BARREL OF MANHOLE IS POURED WITHIN 4 HOURS AFTER BASE IS POURED AND PROVIDED BASE IS CLEANED OF ALL MUD, SILT AND DEBRIS.
- THE TOP STEP SHALL NOT BE MORE THAN 27 INCHES AND NOT LESS THAN 18 INCHES FROM THE TOP OF LID.

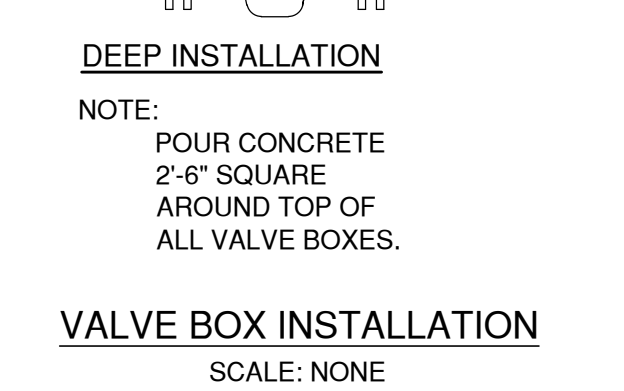

VALVE BOX INSTALLATION
SCALE: NONE

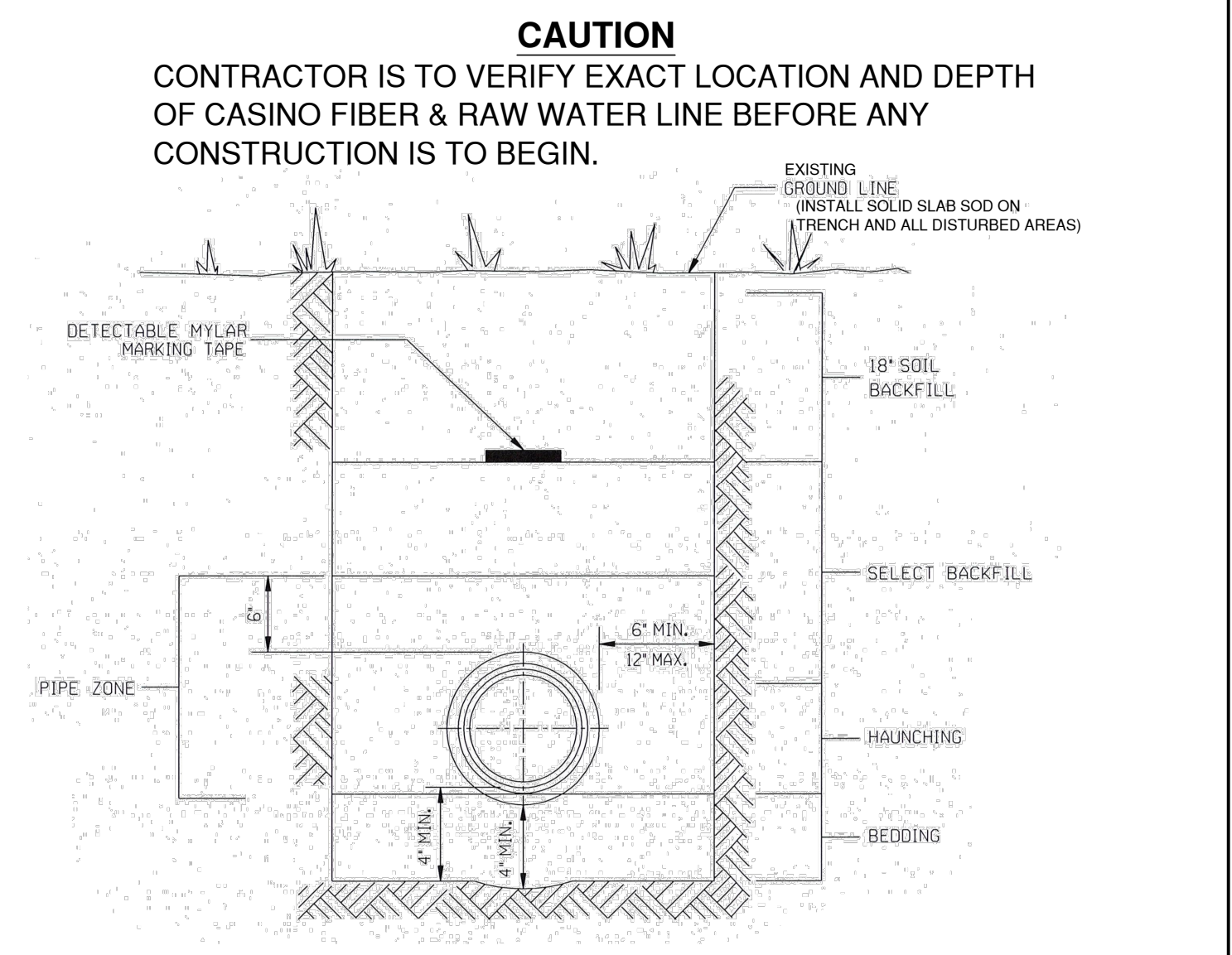

- CAUTION**
CONTRACTOR IS TO VERIFY EXACT LOCATION AND DEPTH OF CASINO FIBER & RAW WATER LINE BEFORE ANY CONSTRUCTION IS TO BEGIN.
- NOTE:**
- BEDDING SHALL BE #67 ROCK.
 - SELECT BACKFILL SHALL BE IN ACCORDANCE WITH ODOT 703.01 AGGREGATE BASE TYPE A PLACED IN HORIZONTAL LIFTS NOT TO EXCEED 8 INCHES AND THE COMPACTED. INITIAL BACKFILL SHALL BE TO THE HAUNCH OF THE PIPE IN HORIZONTAL LIFTS NOT TO EXCEED 6 INCHES AND THE COMPACTED. COMPACTION PROCEDURE AND RESULTS SHALL BE SUBJECT TO APPROVAL OF THE ENGINEER.
 - SOIL BACKFILL SHALL BE IN ACCORDANCE WITH ODOT 616.04.L BACKFILLING.
 - COMPACTION SHALL BE 95% STANDARD PROCTOR DENSITY PER AASHTO T-99.
 - 6" PIPE SHALL BE AWWA CLASS 200.
 - ALL 6" BENDS & FITTINGS SHALL BE D.I.P. AND WITH MEGALUGS RESTRAINTS.
 - ALL 2" PIPE SHALL BE PVC SCH 40.

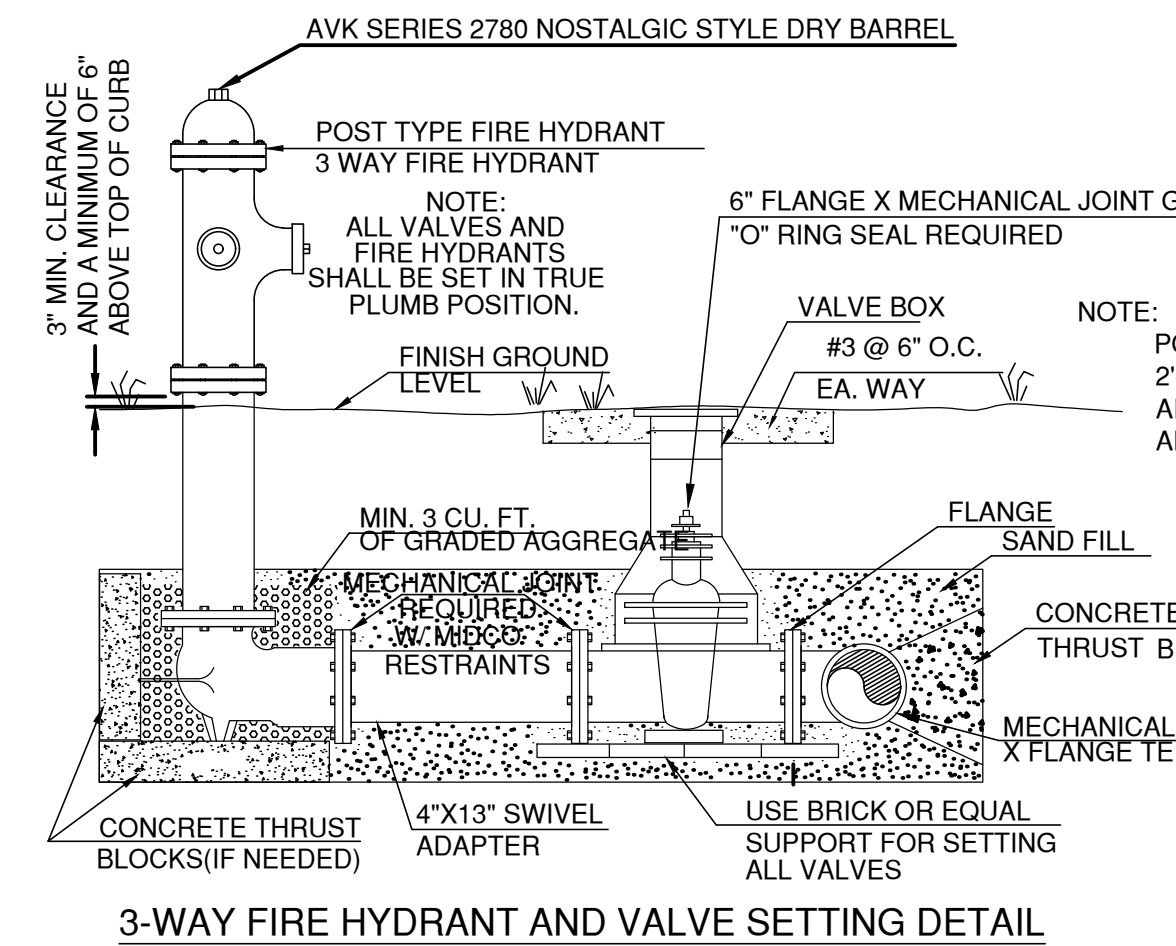
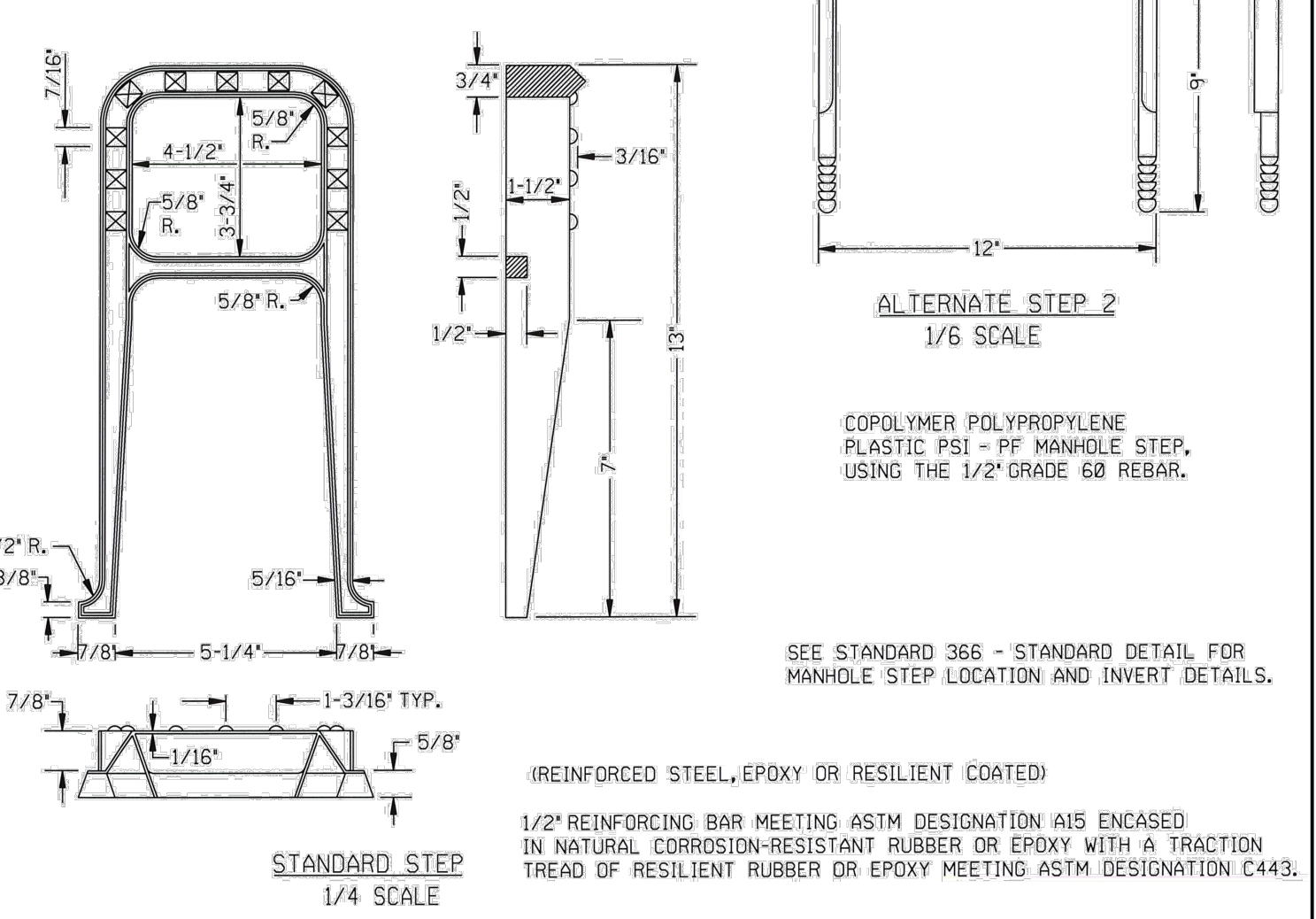

NOTE:
HYDRANT DETAILS SHALL MEET THE CONSTRUCTION REQUIREMENTS LISTED IN OAC 252-626-19-3.

Approved 3 - Way Hydrants
Approved American Darling B84B
AVK Series 2780 Nostalgic Style Dry Barrel
Clown Medallion
East Jordan Water Master 5CD250
Kennedy Guardian
Mueller Centurian (Aquaquip allowed)

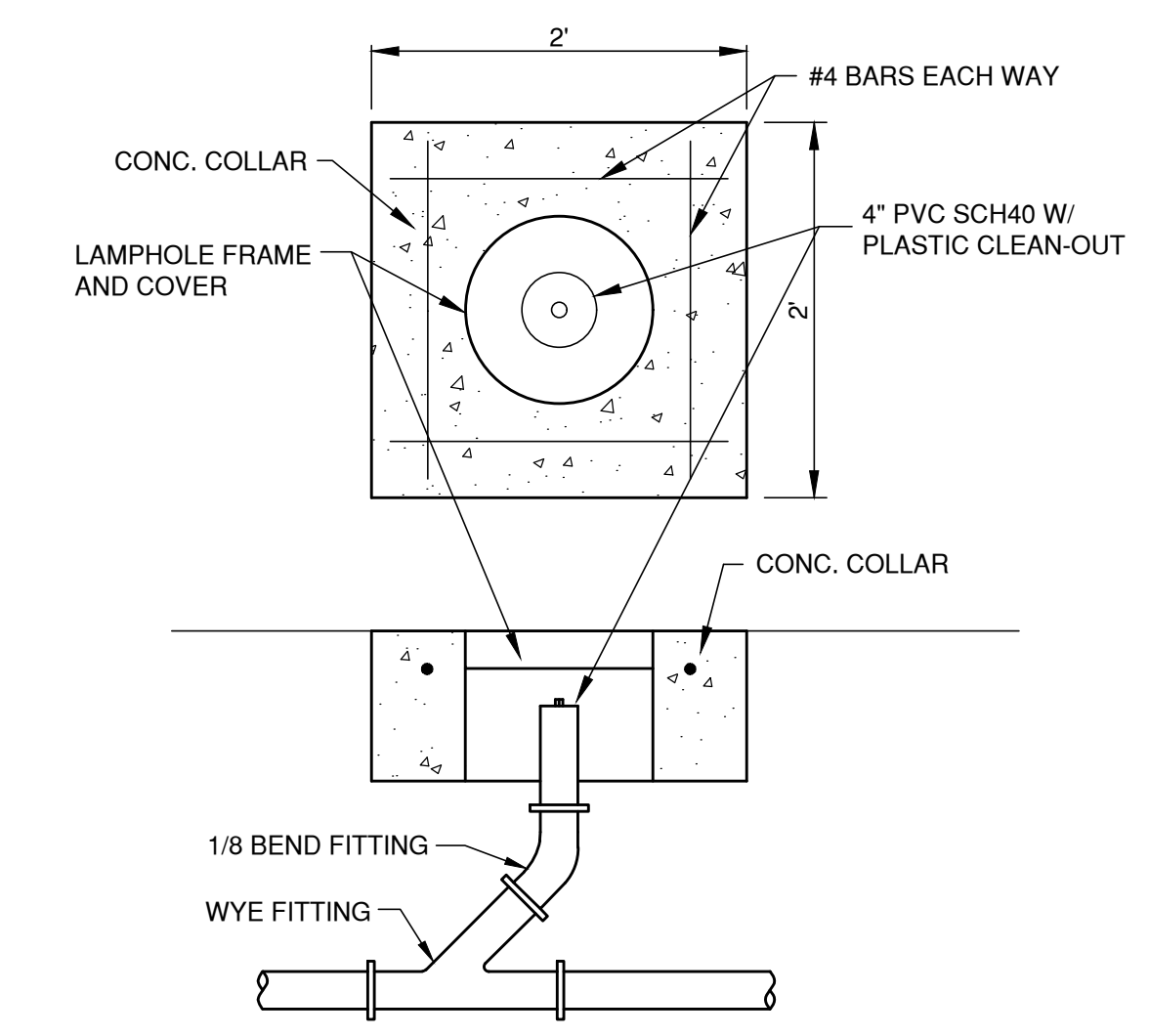

SANITARY SEWER CLEANOUT
NOT TO SCALE

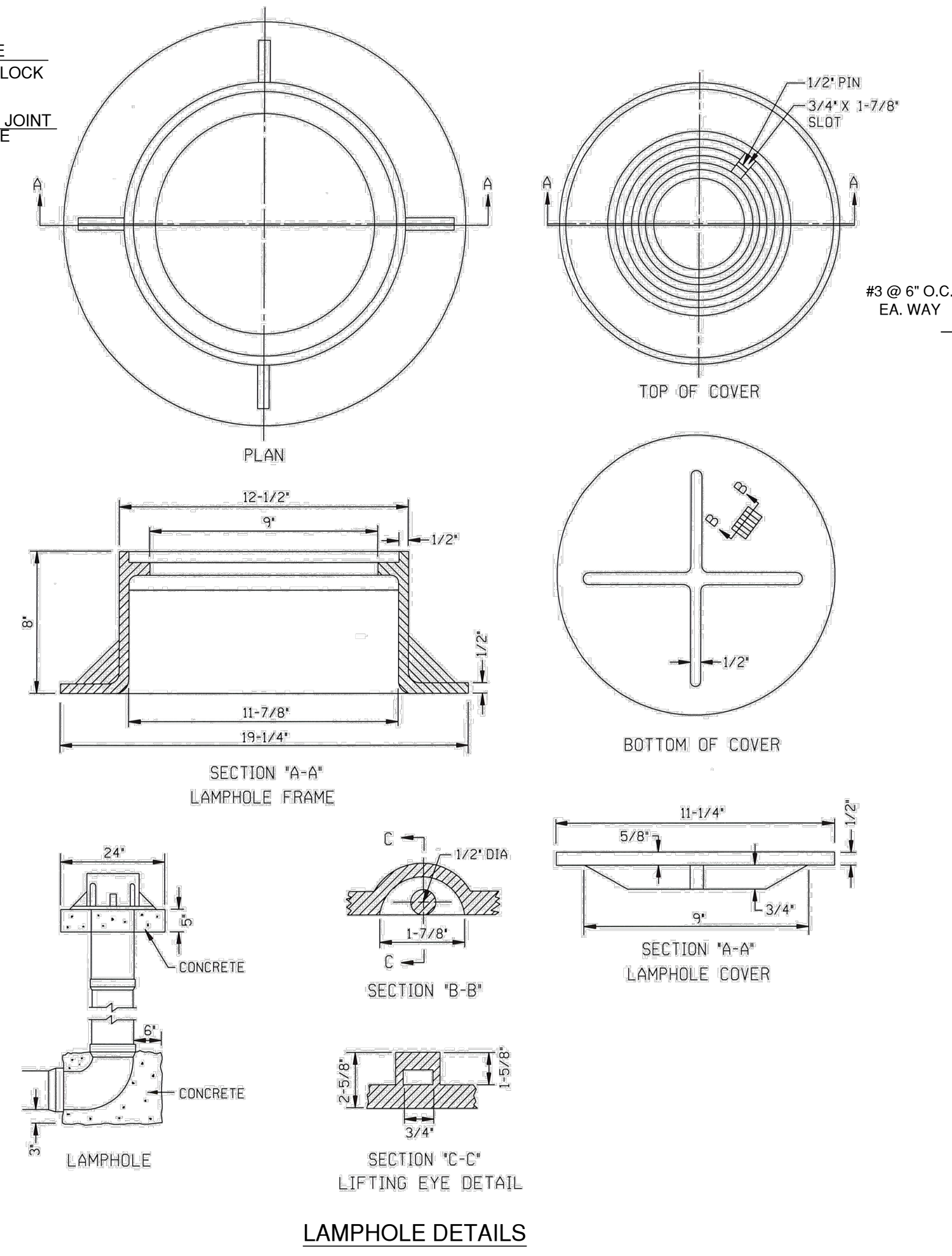

LAMPHOLE DETAILS

OWNER: Cherokee Nation Enterprises (CNE)

811 BEFORE YOU DIG... CALL OKIE

LOCATIONS OF UNDERGROUND UTILITIES WERE OBTAINED FROM THE UTILITY OWNERS. BEFORE DOING ANY WORK WITH HEAVY EQUIPMENT, THE CONTRACTOR SHALL NOTIFY THE UTILITY OWNERS OR "CALL OKIE (OKLAHOMA ONE-CALL)" NOT LESS THAN 48 HOURS IN ADVANCE AND SHALL ESTABLISH THE EXACT LOCATION AND DEPTH OF ALL UNDERGROUND UTILITIES.

REVISIONS	DATE	APPROVED

RICHARD L. KOSMAN, PE. & ASSOCIATES PLC
CIVIL ENGINEERING
4815 South Harvard Ave. Ste. 200
Tulsa, OK. 74135
Phone: 918(277-4784)
Email: rkosman@sbglobal.net
Certificate of Authority No. 4831
Expires June 30, 2023

THESE PLANS AND DRAWINGS MAY NOT BE REPRODUCED, CHANGED OR COPIED, IN ANY WAY UNLESS FIRST OBTAINING THE EXPRESS WRITTEN CONSENT OF RK & ASSOCIATES. NOR SHALL THEY BE ASSIGNED TO ANY THIRD PARTY UNLESS SAID WRITTEN CONSENT IS FIRST OBTAINED. ANY CHANGES MADE TO THESE PLANS WITHOUT THE CONSENT OF RK & ASSOCIATES SHALL RELIEVE RK & ASSOCIATES OF RESPONSIBILITY FOR ANY CONSEQUENCES RESULTING FROM SUCH CHANGES.

NOTES & DETAILS

CHEROKEE NATION ENTERPRISES (CNE)

SHEET 2 OF 5 02222 DATE: 03/07/2023

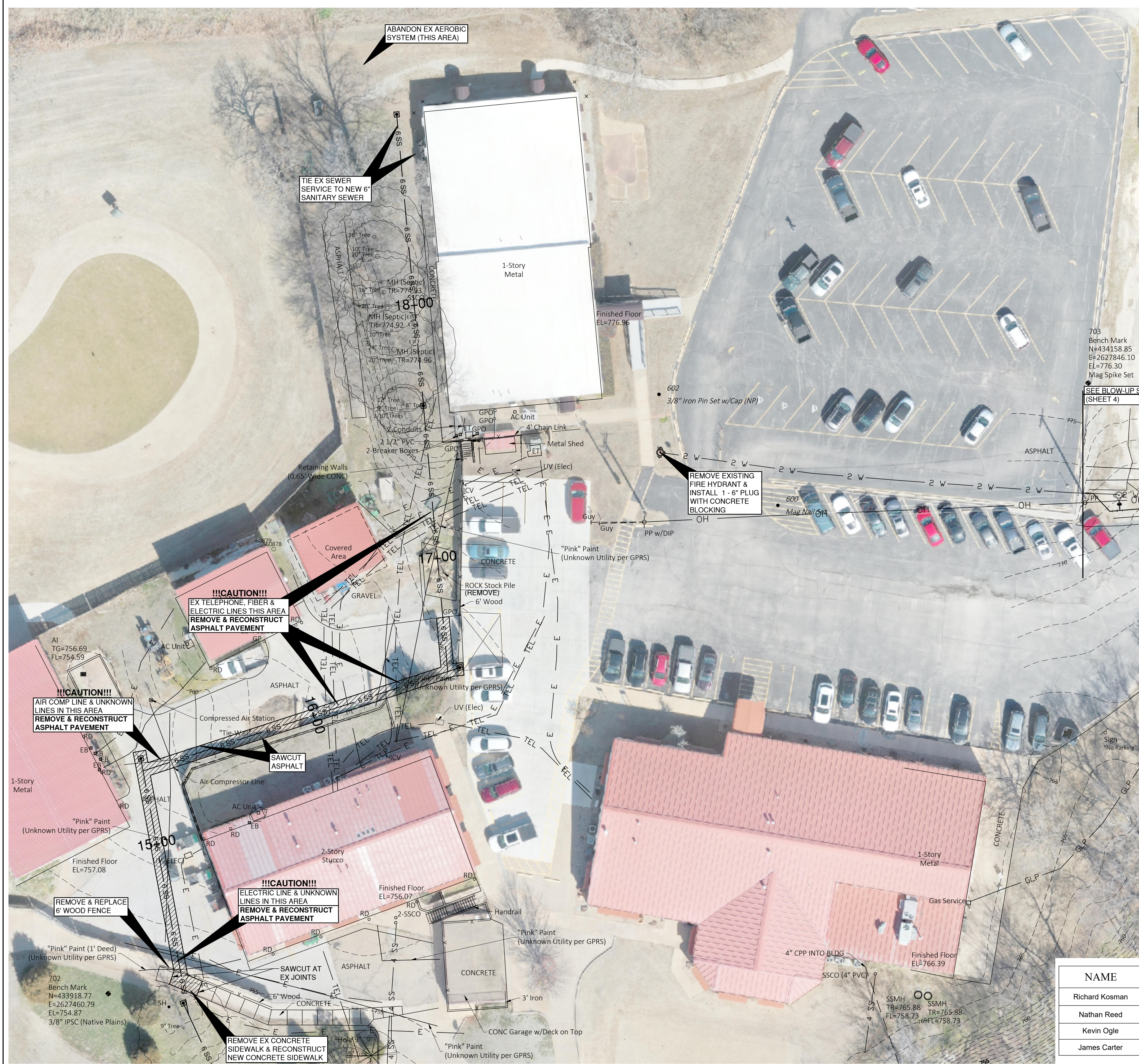
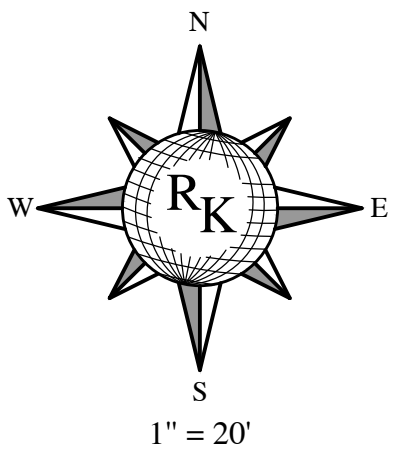

NAME	COMPANY	PHONE NO	CELL NO	EMAIL ADDRESS	ADDRESS
Richard Kosman	RK & Associates PLC	(918) 277-4784	(918) 277-4784	rkosman@sbcglobal.net	4815 South Harvard Avenue, Suite 290, Tulsa, OK 74135
Nathan Reed	Native Plains Surveying & Mapping	(918) 234-4859	(918) 914-9250	nathan@nativeplains.us	5807 South Garnett Road, Stek, Tulsa, OK 74146
Kevin Ogle	CNE		(918) 906-6188	kevin.ogle@cn-bus.com	777 Cherokee Drive, Catoosa, OK 74135
James Carter	CNE		(918) 232-2173	james.carter@cnet.com	777 Cherokee Drive, Catoosa, OK 74135

CONTACT LIST

OWNER: Cherokee Nation Enterprises (CNE)

811 BEFORE YOU DIG ... CALL OKIE

LOCATIONS OF UNDERGROUND UTILITIES WERE OBTAINED FROM THE UTILITY OWNERS. BEFORE DOING ANY WORK WITH HEAVY EQUIPMENT, THE CONTRACTOR SHALL NOTIFY THE UTILITY OWNERS OR "CALL OKIE (OKLAHOMA ONE-CALL)" NOT LESS THAN 48 HOURS IN ADVANCE AND SHALL ESTABLISH THE EXACT LOCATION AND DEPTH OF ALL UNDERGROUND UTILITIES.

REVISIONS	DATE	APPROVED

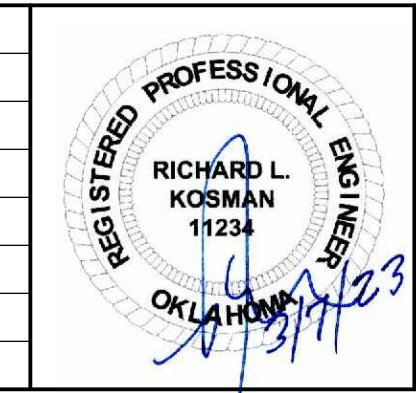

RICHARD L. KOSMAN, PE. & ASSOCIATES PLC
 CIVIL ENGINEERING
 4815 South Harvard Ave. Ste. 290
 Tulsa, OK 74135
 Phone: 918(277-4784)
 Email: rkosman@sbcglobal.net
 Certificate of Authority No. 4831
 Expires June 30, 2023

THESE PLANS AND DRAWINGS MAY NOT BE REPRODUCED, CHANGED OR COPIED, IN ANY WAY UNLESS FIRST OBTAINING THE EXPRESS WRITTEN CONSENT OF RK & ASSOCIATES, NOR SHALL THEY BE ASSIGNED TO ANY THIRD PARTY UNLESS SAID WRITTEN CONSENT IS FIRST OBTAINED. ANY CHANGES MADE TO THESE PLANS WITHOUT THE CONSENT OF RK & ASSOCIATES SHALL RELIEVE RK & ASSOCIATES OF RESPONSIBILITY FOR ANY CONSEQUENCES RESULTING FROM SUCH CHANGES.

BLOW-UP PLAN		
CHEROKEE NATION ENTERPRISES (CNE)		
SHEET 3 OF 5	02222	DATE: 03/07/2023

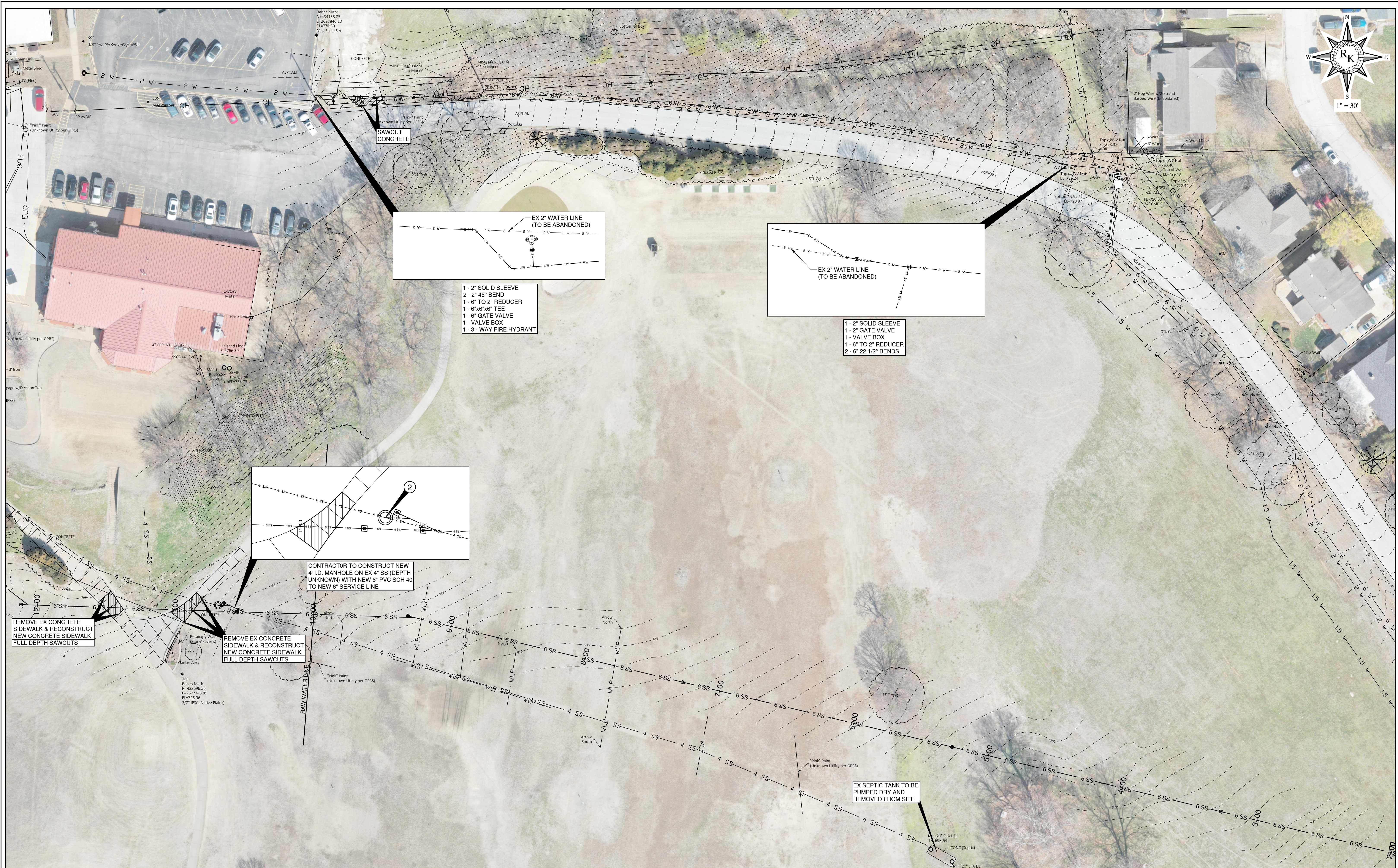

OWNER: Cherokee Nation Enterprises (CNE)

811 BEFORE YOU DIG... CALL OKIE

LOCATIONS OF UNDERGROUND UTILITIES WERE OBTAINED FROM THE UTILITY OWNERS. BEFORE DOING ANY WORK WITH HEAVY EQUIPMENT, THE CONTRACTOR SHALL NOTIFY THE UTILITY OWNERS OR "CALL OKIE (OKLAHOMA ONE-CALL)" NOT LESS THAN 48 HOURS IN ADVANCE AND SHALL ESTABLISH THE EXACT LOCATION AND DEPTH OF ALL UNDERGROUND UTILITIES.

REVISIONS	DATE	APPROVED

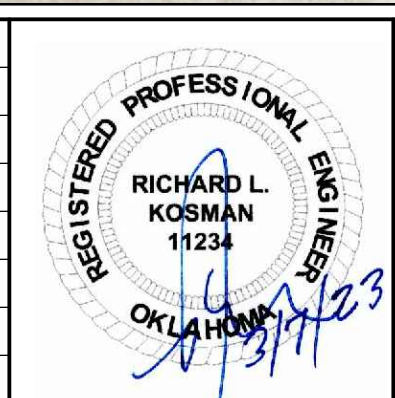

RICHARD L. KOSMAN, PE. & ASSOCIATES PLC
 CIVIL ENGINEERING
 4815 South Harvard Ave. Ste. 200
 Tulsa, OK, 74135
 Phone: 918(277-4784)
 Email: rkosman@sbcglobal.net
 Certificate of Authority No. 4831
 Expires June 30, 2023

THESE PLANS AND DRAWINGS MAY NOT BE REPRODUCED, CHANGED OR COPIED, IN ANY WAY UNLESS FIRST OBTAINING THE EXPRESS WRITTEN CONSENT OF RK & ASSOCIATES, NOR SHALL THEY BE ASSIGNED TO ANY THIRD PARTY UNLESS SAID WRITTEN CONSENT IS FIRST OBTAINED. ANY CHANGES MADE TO THESE PLANS WITHOUT THE CONSENT OF RK & ASSOCIATES SHALL RELIEVE RK & ASSOCIATES OF RESPONSIBILITY FOR ANY CONSEQUENCES RESULTING FROM SUCH CHANGES.

BLOW-UP PLAN		
CHEROKEE NATION ENTERPRISES (CNE)		
SHEET 4 OF 5	02222	DATE: 03/07/2023

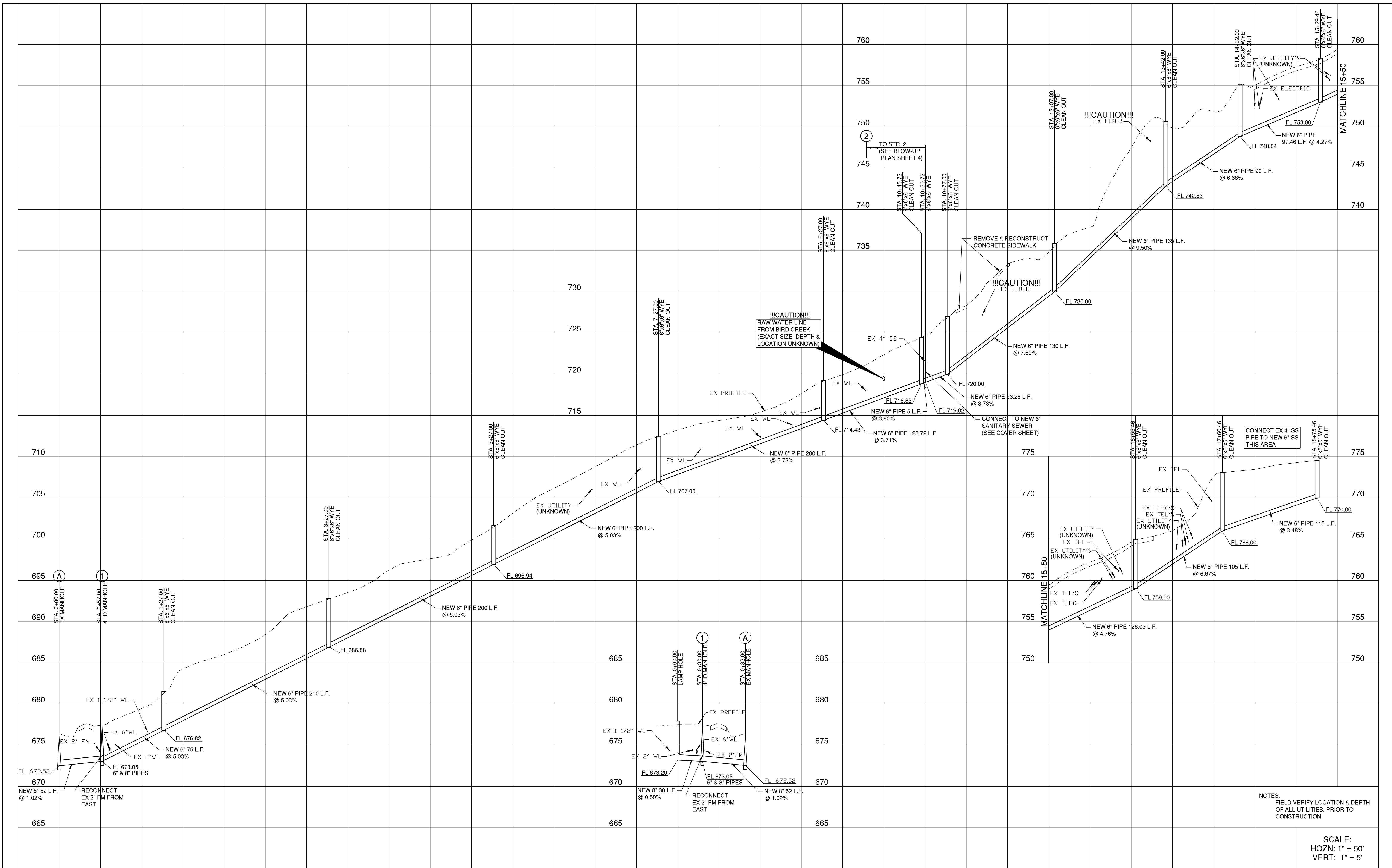

NOTES:
FIELD VERIFY LOCATION & DEPTH
OF ALL UTILITIES. PRIOR TO
CONSTRUCTION.

SCALE:
HOZN: 1" = 50'
VERT: 1" = 5'

OWNER: Cherokee Nation Enterprises (CNE)

811 BEFORE YOU DIG ... CALL OKIE

LOCATIONS OF UNDERGROUND UTILITIES WERE OBTAINED FROM THE UTILITY OWNERS. BEFORE DOING ANY WORK WITH HEAVY EQUIPMENT, THE CONTRACTOR SHALL NOTIFY THE UTILITY OWNERS OR "CALL OKIE (OKLAHOMA ONE-CALL)" NOT LESS THAN 48 HOURS IN ADVANCE AND SHALL ESTABLISH THE EXACT LOCATION AND DEPTH OF ALL UNDERGROUND UTILITIES.

REVISIONS	DATE	APPROVED

RICHARD L. KOSMAN, PE.
& ASSOCIATES PLC
CIVIL ENGINEERING

4815 South Harvard Ave. Ste. 200
Tulsa, OK, 74135
Phone: 918(277-4784)
Email: rkosman@sbcglobal.net
Certificate of Authority No. 4831
Expires June 30, 2023

THESE PLANS AND DRAWINGS MAY NOT BE REPRODUCED, CHANGED OR COPIED, IN ANY WAY UNLESS FIRST OBTAINING THE EXPRESS WRITTEN CONSENT OF RK & ASSOCIATES. NOR SHALL THEY BE ASSIGNED TO ANY THIRD PARTY UNLESS SAID WRITTEN CONSENT IS FIRST OBTAINED. ANY CHANGES MADE TO THESE PLANS WITHOUT THE CONSENT OF RK & ASSOCIATES SHALL RELIEVE RK & ASSOCIATES OF RESPONSIBILITY FOR ANY CONSEQUENCES RESULTING FROM SUCH CHANGES.

PROFILES & DETAILS

CHEROKEE NATION ENTERPRISES (CNE)

SHEET 5 OF 5 02222 DATE: 03/07/2023