

# SINGLE FAMILY HOME, 3 BR ADA

HOUSING AUTHORITY OF THE CHEROKEE NATION  
N. SHERIDAN RD. & E. 136TH ST. N. COLLINSVILLE, OK

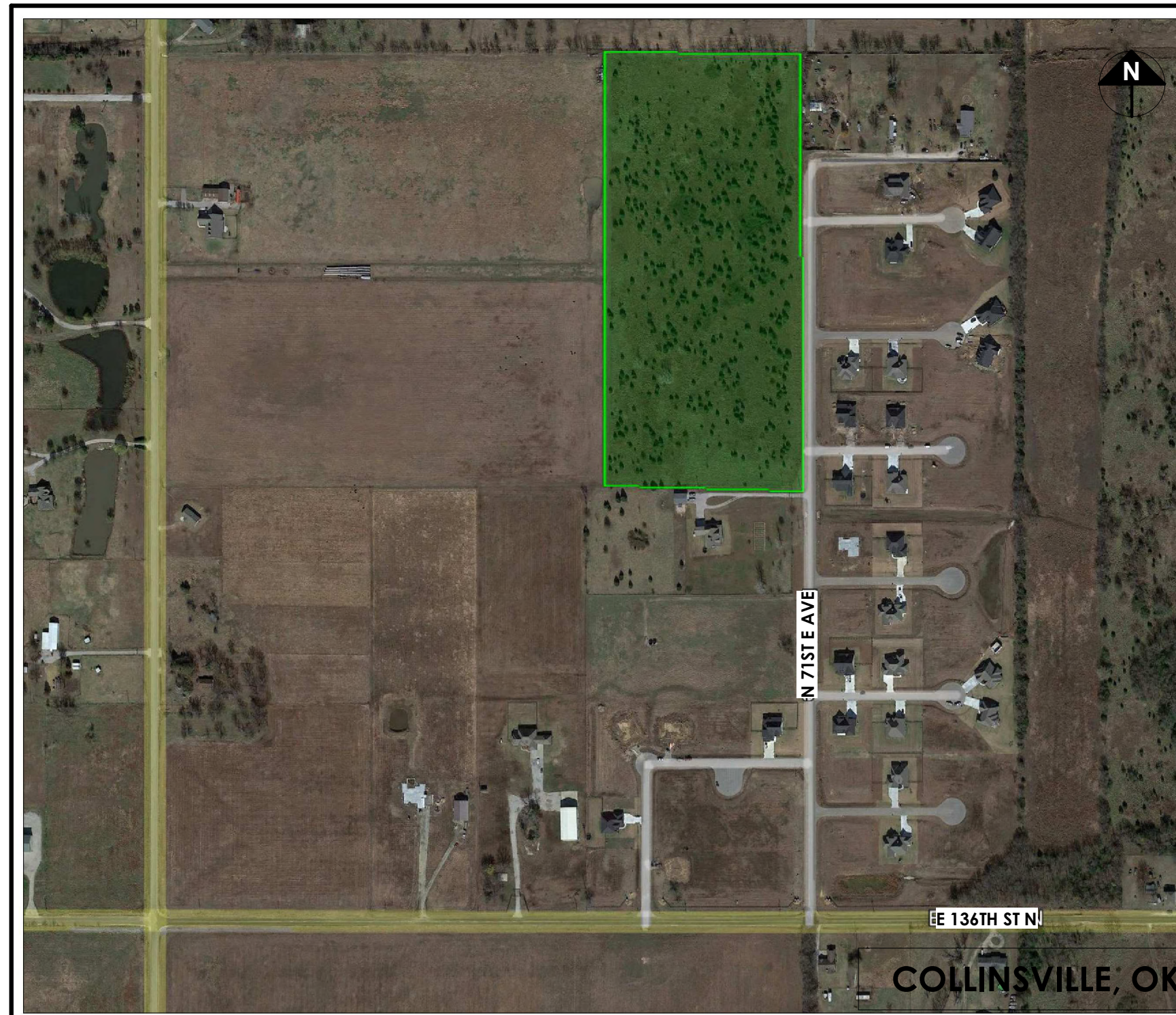

ABOVE IMAGE IS CONCEPTUAL REFER TO ORTHOGRAPHIC DRAWINGS FOR SPECIFIC REQUIREMENTS



INDEX OF DRAWINGS			
<b>.GENERAL</b>	<b>ARCHITECTURE</b>	<b>A600</b>	<b>FLOOR &amp; WALL FINISH PLAN</b>
.G000 COVER SHEET	A101 FLOOR PLAN & ROOF PLAN	A610	INTERIOR ELEVATIONS
.G001 ARCHITECTURAL SPECIFICATIONS	A130 REFLECTED CEILING PLAN	9	
.G002 PLUMBING SPECIFICATIONS	A300 EXTERIOR ELEVATIONS - FRONT		<b>PLUMBING</b>
.G003 MECHANICAL SPECIFICATIONS	A301 EXTERIOR ELEVATIONS	P101	PLUMBING PLAN
.G004 ELECTRICAL SPECIFICATIONS	A302 BUILDING SECTIONS	1	
5	A310 WALL SECTIONS		<b>MECHANICAL</b>
	A500 SPECIALTIES, DOORS & WINDOWS		M101 MECHANICAL PLAN
			1
<b>STRUCTURAL</b>			<b>Grand total: 20</b>
S001 GENERAL NOTES			
S101 STRUCTURAL FOUNDATIONS PLAN/ DETAILS			
S102 FRAMING DETAILS			
S103 ROOF AND CEILING FRAMING PLANS			
4			

## PROJECT TEAM

### ARCHITECT:

TriArch  
www.tri-arch.com  
618 E 3rd St.  
Tulsa OK 74120  
PHONE (918) 743-2724

Tony Popp  
tpopp@Tri-Arch.com



O N M L K J I H G F E D C B A

ABBREVIATIONS			
<b>A</b>	ANCHOR BOLT	<b>G</b>	GAUGE
AB	AIR CONDITIONING	GA	GALVANIZED
ACP	ACOUSTICAL PANEL	GB	GRAB BAR
ACT	ACOUSTICAL CEILING TILE	GCMU	GLAZED CONCRETE
AD	AREA DRAIN		MASONRY UNIT
ADH	ADHESIVE	GD	GRADE
ADJ	ADJUSTABLE	GL	GLASS
AFF	ABOVE FINISH FLOOR	GR	GRONMET
AL	ALUMINUM	GSL	GLAZED STRUCTURAL UNIT
ALT	ALTERNATE	GRNBD	GREEN BOARD
AMB	AMBULATORY	GYP	GYP SUM
ANSI	AMERICAN NATIONAL STANDARDS INSTITUTE	<b>H</b>	
AP	ACCESS PANEL	HB	HOSE BIBB
APPROX	APPROXIMATE	H/C	HANDICAPPED
ARCH	ARCHITECT(U)RAL	HC	HOLLOW CORE
ASPH	ASPHALT	HD	HEAVY DUTY
AUTO	AUTOMATIC	HDR	HEADER
<b>B</b>		HDW	HARDWARE
BD	BOARD	HK	HOOK
BIT	BITUMINOUS	HM	HOLLOW METAL
BDLG	BUILDING	HR	HORIZONTAL
BL	WINDOW BLINDS	HP	HORSEPOWER
BLKG	BLOCKING	HR	HOUR
BM	BENCH MARK, BEAM	HT	HEIGHT
BO	BY OWNER, BY OTHERS	HVAC	HEATING, VENTILATING, AIR CONDITIONING
BR	BRACKET	HWD	HARDWOOD
BRG	BEARING	<b>I</b>	
BTB	BACK TO BACK	INSUL	INSULATION
BUR	BUILT-UP ROOFING	INT	INTERIOR
<b>C</b>		<b>J</b>	
CAB	CABINET	JAN	JANITOR'S CLOSET
CB	CATCH BASIN	JB	JUNCTION BOX
CBB	CEMENTITIOUS BACKING BOARD	JOH	JAMB OPENING HEIGHT
CF	CUBIC FEET	JOW	JAMB OPENING WIDTH
CFM	CUBIC FEET PER MINUTE	<b>K</b>	
CG	CORNER GUARD	KD	KNOCKDOWN
CJ	CAST IRON	KG	KILOGRAM
CL	CAST IN PLACE	KIT	KITCHEN
CJ	CONTROL JOINT	KO	KNOCKOUT
CL	CENTERLINE	KVA	KILOVOLT AMPERES
CLG	CEILING	KW	KILOWATTS
CLR	CLEAR(ANCE)	<b>L</b>	
CM	CONSTRUCTION MANAGER	L	LENGTH
CMU	CONCRETE MASONRY UNIT	LAM	LAMINATE(D)
COL	COLUMN	LAV	LAVATORY
CONC	CONCRETE	LBS	POUNDS
CONST	CONSTRUCTION	LKR	LOCKER
CONT	CONTINUOUS	LL	LIVE LOAD
CORR	CORRIDOR	LLH	LONG LEG HORIZONTAL
CPT	CARPET	LLV	LONG LEG VERTICAL
CSMT	CASEMENT	LVR	LOUVER
CT	CERAMIC TILE	LVT	LUXURY VINYL TILE
CY	CUBIC YARD	L/G	LIGHTWEIGHT
<b>D</b>		<b>M</b>	
D	DRAIN	M	METER
DBL	DOUBLE	MAINT	MAINTENANCE
DEG	DEGREES	MAX	MAXIMUM
DEMO	DEMOLISH, DEMOLITION	MBR	MEMBRANE
DH	DOUBLE HUNG	MC	MEDICINE CABINET
DIA	DIAMETER	MECH	MECHANICAL
DIAG	DIAGONAL	MEZZ	MEZZANINE
DIM	DIMENSION	MFR	MANUFACTURER
DIV	DIVISION	MH	MANHOLE
DL	DEAD LOAD	MIN	MINIMUM
DN	DOWN	MI	MIRROR
DP	DAMP PROOFING	MISC	MISCELLANEOUS
DR	DOOR	MKRD	MARKER BOARD
DS	DOWNSPOUT	MLDG	MOULDING
DWG	DRAWING	MM	MILLIMETER
DWR	DRAWER	MO	MASONRY OPENING
<b>E</b>		MPJ	MULTIPURPOSE UNIT
E	EAST	MR	MOP RACK
EB	EXPANSION BOLT	MTG	MOUNTING
EJ	EXPANSION JOINT	MTL	MATERIAL
EL	ELEVATION	MULL	MULLION
ELEC	ELECTRIC(AL)	<b>N</b>	
ELEV	ELEVATOR, ELEVATION	N	NORTH
ENGR	ENGINEER	NE	NORTHEAST
EQ	EQUAL	NIC	NOT IN CONTRACT
EQUIP	EQUIPMENT	NOM	NOMINAL
ES	EACH SIDE	NPS	NOMINAL PIPE SIZE
EW	EACH WAY	<b>O</b>	
EXH	EXHAUST	OC	ON CENTER
EXP	EXPOSED	OD	OUTSIDE DIAMETER
EXT	EXTERIOR	OH	OVERHEAD
EXIST	EXISTING	OTO	OUT TO OUT
FA	FIRE ALARM	OZ	OUNCE
FB	FACE BRICK	<b>P</b>	
FD	FLOOR DRAIN	PBD	PARTICLEBOARD
FE	FIRE EXTINGUISHER	P/C	PRECAST (CONCRETE)
FEC	FIRE EXTINGUISHER CABINET	PC	POLISHED CONCRETE
FF	FACTORY FINISH	PCF	POUNDS PER CUBIC FOOT
FFE	FURNITURE, FIXTURES, & EQUIPMENT	PE	PORCELAIN ENAMEL
FFL	FINISH FLOOR LINE	PEJ	PREFORMED
FHC	FIRE HOSE CABINET	PFB	EXPANSION JOINT
FL	FLOOR FLOORING	PL	PREFABRICATED
FOC	FACE OF CONCRETE	PL	PLATE, PROPERTY LINE,
FOF	FACE OF FINISH	PLAM	PLASTIC LAMINATE
FOM	FACE OF MASONRY	PLBG	PLUMBING
FOS	FACE OF STUDS	PLYWD	PLYWOOD
FP	FIREPROOF	PNL	PANEL(S)
FRT	FIRE RETARDANT TREATED	PR	PAIR
FSR	FLEXIBLE SHEET ROOFING	PSF	POUNDS PER SQUARE FOOT
FT	FOOT, FEET	PSI	POUNDS PER SQUARE INCH
FTG	FOOTING	PT	PAINT, POINT
FUR	FURRING	PVC	POLYVINYL CHLORIDE
FURN	FURNITURE	PVG	PAVING
<b>Q</b>		<b>QT</b>	QUARTZ
<b>R</b>		<b>R</b>	RADIUS
RA	RETURN AIR	RA	RETURN AIR
RB	RUBBER BASE	RD	RUBBER FLOOR
RD	ROOF DRAIN	RFG	ROOFING
REF	REFERENCE, REFRIGERATOR	RM	ROOM
REINFC	REINFORCING, REINFORCEMENT	RO	ROUGH OPENING
REQ	REQUIRED	ROW	RIGHT-OF-WAY
RES	RESILIENT	RPM	REVOLUTIONS PER MINUTE
REV	REVISION	RS	ROLLER SHADES
RF	RUBBER FLOOR	RTU	ROOF TOP UNIT (HVAC)
RFG	ROOFING	RV	ROOF VENT PENETRATION
RM	ROOM	<b>S</b>	
RO	ROUGH OPENING	S	SOUTH
ROW	RIGHT-OF-WAY	SATB	SOUND ATTENUATION BLANKET
RPM	REVOLUTIONS PER MINUTE	SC	SOLID CORE, SEALED CONCRETE
RS	ROLLER SHADES	SCH	SCHEDULE, SCHLUTER
RTU	ROOF TOP UNIT (HVAC)	SD	STORM DRAIN
RV	ROOF VENT PENETRATION	SE	SOUTHEAST
<b>S</b>		SECT	SECTION
S	SOUTH	SF	SQUARE FOOT
SATB	SOUND ATTENUATION BLANKET	SGL	SAFETY GLASS
SC	SOLID CORE, SEALED CONCRETE	SIM	SIMILAR
SCH	SCHEDULE, SCHLUTER	SNR	SANITARY NAPKIN RECEPTACLE
SD	STORM DRAIN	SP	SOUNDPROOF
SE	SOUTHEAST	SPEC	SPECIFICATIONS
SECT	SECTION	SQ	SQUARE
SF	SQUARE FOOT	SR	SHOWER ROD
SGL	SAFETY GLASS	SS	SERVICE SINK, STAINLESS STEEL
SIM	SIMILAR	SS	SOLID SURFACE
SNR	SANITARY NAPKIN RECEPTACLE	STD	STANDARD
SP	SOUNDPROOF	STG	SEATING
SPEC	SPECIFICATIONS	STL	STEEL
SQ	SQUARE	STOR	STORAGE
SR	SHOWER ROD	STP	STANDPIPE
SS	SERVICE SINK, STAINLESS STEEL	STRUC	STRUCTURAL
SS	SOLID SURFACE	SW	SOUTHWEST
STD	STANDARD	SYM	SYMMETRICAL
STG	SEATING	SY	SYSTEM
STL	STEEL	<b>T</b>	
STOR	STORAGE	TB	TILE BASE
STP	STANDPIPE	T/C	TOP OF CURB
STRUC	STRUCTURAL	TD	TOWEL DISPENSER
SW	SOUTHWEST	TDWR	TOWEL DISPENSER & WASTE
SYM	SYMMETRICAL	TEL	TELEPHONE
SY	SYSTEM	TEMP	TEMPERATURE
<b>T</b>		TGL	TEMPERED GLASS
TB	TILE BASE	TH	TOWEL HOOK, THICK(NESS)
T/C	TOP OF CURB	THR	THRESHOLD
TD	TOWEL DISPENSER	TL	TOILET
TDWR	TOWEL DISPENSER & WASTE	TOPO	TOPOGRAPHY MAP
TEL	TELEPHONE	TTD	TOILET TISSUE DISPENSER
TEMP	TEMPERATURE	TRT	TREATED (PRESERVATIVE)
TGL	TEMPERED GLASS	T/S	TOP OF SLAB
TH	TOWEL HOOK, THICK(NESS)	T/STL	TOP OF STEEL
THR	THRESHOLD	TV	TELEVISION
TL	TOILET	T/W	TOP OF WALL
TOPO	TOPOGRAPHY MAP	TYP	TYPICAL
TTD	TOILET TISSUE DISPENSER	T&B	TOP AND BOTTOM
TRT	TREATED (PRESERVATIVE)	T&G	TONGUE AND GROOVE
T/S	TOP OF SLAB	<b>U</b>	
T/STL	TOP OF STEEL	UC	UNDERCUT
TV	TELEVISION	UH	UNIT HEATER
T/W	TOP OF WALL	UNFIN	UNFINISHED
TYP	TYPICAL	US	UTILITY SHELF
T&B	TOP AND BOTTOM	UTIL	UTILITY
T&G	TONGUE AND GROOVE	<b>V</b>	
<b>U</b>		V	VENT
UC	UNDERCUT	VB	VAPOR BARRIER
UH	UNIT HEATER	VCT	VINYL COMPOSITION TILE
UNFIN	UNFINISHED	VERT	VERTICAL
US	UTILITY SHELF	VIN	VINYL (SHEET)
UTIL	UTILITY	VJ	V-JOINED(ED)
<b>V</b>		VOL	VOLUME
V	VENT	<b>W</b>	
VB	VAPOR BARRIER	W	WEST, WIDTH
VCT	VINYL COMPOSITION TILE	W/	WITH
VERT	VERTICAL	WC	WATER CLOSET, WALL COVERING
VIN	VINYL (SHEET)	WD	WOOD
VJ	V-JOINED(ED)	WH	WATER HEATER
VOL	VOLUME	WM	WIRE MESH
<b>W</b>		W/O	WITHOUT
W	WEST, WIDTH	WP	WATERPROOFING
W/	WITH	WSC	WASTE RECEPTACLE
WC	WATER CLOSET, WALL COVERING	WT	WEIGHT
WD	WOOD	WWF	WELDED WIRE FABRIC
WH	WATER HEATER	<b>Y</b>	
WM	WIRE MESH	YD	YARD
W/O	WITHOUT		
WP	WATERPROOFING		
WSC	WASTE RECEPTACLE		
WT	WEIGHT		
WWF	WELDED WIRE FABRIC		
<b>Y</b>			
YD	YARD		

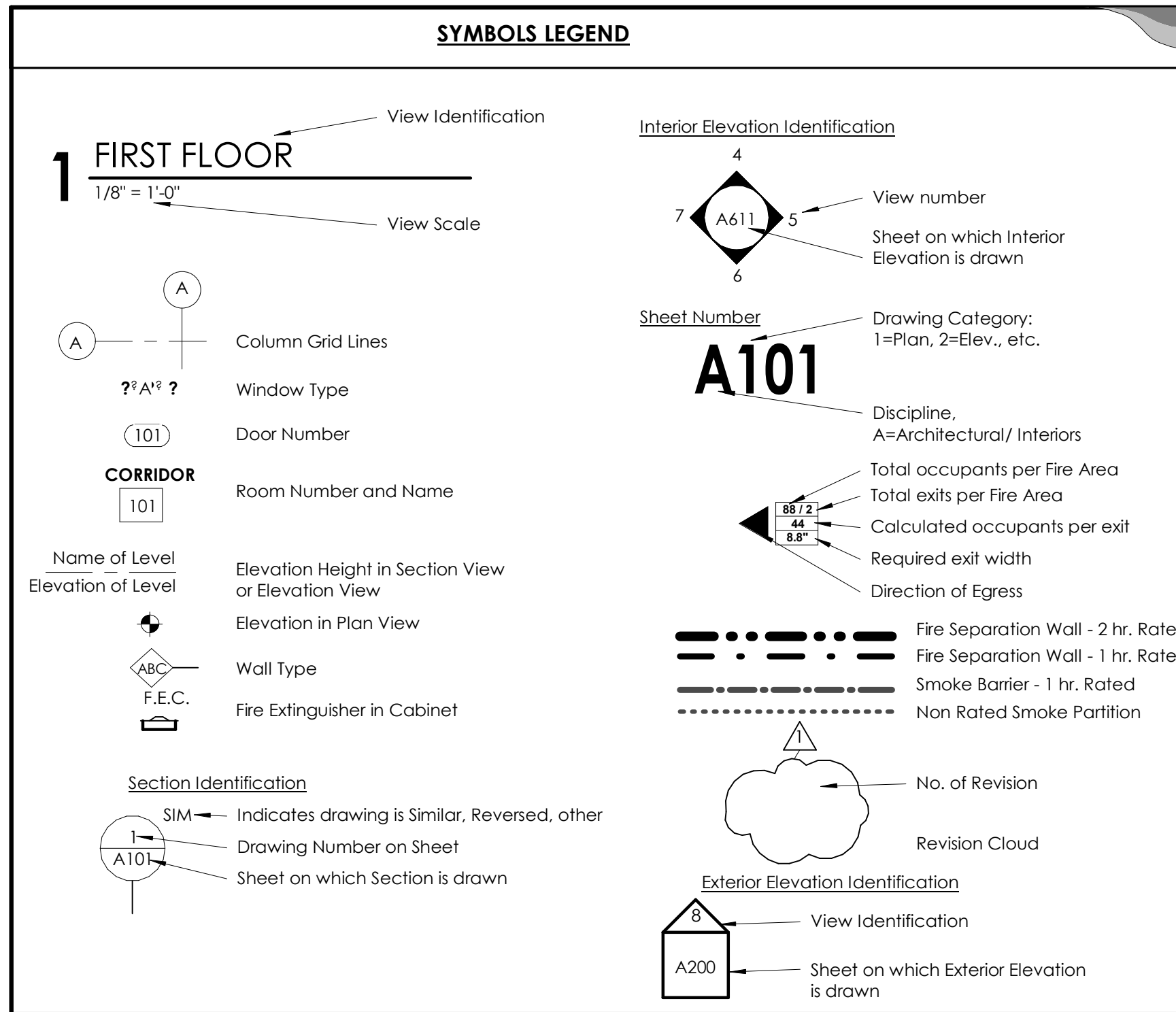

**TriArch**  
Purpose. Driven. Architecture.  
618 E 3rd St.  
Tulsa, OK 74120  
918.743.2724 (M)  
918.743.2724 (F)

**REVISIONS**

No.	Description	Date

Consultants

**SINGLE FAMILY HOME  
3 BR ADA HOME**

HOUSING AUTHORITY OF  
THE CHEROKEE NATION  
N. SHERIDAN RD. & E. 136TH ST. N.  
COLLINSVILLE, OK

Key Plan

**CONSTRUCTION DOCUMENTS**

PROJECT NO. 01-2207

SHEET TITLE: COVER SHEET

DRAWN BY: Author  
CHECKED BY: Checker  
ISSUE DATE: 2 -14-2022

**G000**

This document and the ideas and designs incorporated herein are an instrument of professional service. In the property of TriArch, and are not to be re-used, reproduced, or otherwise disseminated without the written authorization of TriArch.  
 PRINT THIS SHEET FULL SIZE (11" X 17")



Following NEC Code Standards are typical and may not be current or accurate for all applications or jurisdictions. Always contact your local building authority for complete and up to date code information.

- 110  
 14. U.L. listed anti-oxidant compound shall be used on all aluminum conductor terminations, unless product information specifically states that it is not required.  
 14. Any underground wiring shall be rated for underground use. Any splicing of underground wiring shall use wire splicing means specifically intended for underground use.  
 14. Only one conductor shall be installed under a terminal screw. In boxes with more than one ground wire, the ground wires shall be spliced with a wire tail, or pig tail attached to the grounding terminal screw.

- 300  
 3. All conductors of the same circuit, including grounded conductors, shall be contained in the same raceway, cable, or trench.  
 4. In both exposed and concealed locations, where cables are installed through bored holes in joists, rafters, or wood framing members, the holes shall be bored so that the edge of the hole is not less than 1 1/4 inch from the nearest edge of the wood member. Where this distance cannot be maintained, the cable shall be protected from penetration by screws or nails by a steel plate at least 1/16th inch thick and of appropriate length and width, protective sleeves, or equivalent.  
 14. At all boxes there shall be a minimum wire length of 6 inches, with at least 3 inches outside the box.  
 15. All splices, including ground wires, shall be made with an approved splice cap or wire nut and shall be made in approved electrical boxes or enclosures.  
 22. Wiring is only permitted to travel through the cold-air returns but not other ducts, plenums, or other air handling spaces. If Type NM cable must be installed in spaces used for cold air returns, NM is only permitted to pass through perpendicular to the long dimension of such spaces.

- 314  
 11. All electrical equipment, metal boxes, cover plates, and plaster rings shall be grounded. All switches, including dimmer switches, shall be grounded.  
 16. Each wire entering a box and terminating or splicing therein is counted as one wire. Interior box clamps all count as one conductor. Each device shall count as two conductors based on the largest conductor connected to it.  
 17. All openings in boxes shall be effectively closed. When openings in non-metallic boxes are broken out and not used, the entire box must be replaced.  
 17. Outer jacket of NM cable shall extend into the box a minimum of 1 inch.  
 19. Junction boxes shall be installed so that the wiring contained in them can be rendered accessible without removing any part of the building.  
 23. All electrical boxes shall be rigidly secured to the building structure.  
 25. In completed installations, each lighting box shall have a lamp-holder, canopy or device with an appropriate cover plate.  
 27. When boxes are used as the sole support for a ceiling paddle fan, they shall be listed and labeled for such use. Fans that exceed 50 pounds must be supported independently of the box.

- 334  
 24. Bends in Romex cable shall be made so the radius of the curve of the inner edge of the bend is not smaller than 5 times the diameter of the cable.

- 336  
 18. Type NM (nonmetallic) cable shall be secured at intervals not greater than 12 feet and within 12 inches of each box. However, if a single gang device box without a clamp is used, the cable shall be secured within 8 inches of the box.

- 352  
 26. Maximum bends of conduit shall not exceed 360 degrees total.

- 370  
 2. Nonmetallic sheathed cable shall be supported every 4.5 feet and within 12 inches of every box.  
 4. Metal boxes, cover plates, and plaster rings shall be grounded. Switches, including dimmer switches, shall be grounded and shall provide a means to ground metal cover plates.  
 16. The volume of electrical boxes shall be sufficient for the number of conductors, devices, and cable clamps contained within the box. Nonmetallic boxes are marked with their cubic inch capacity:

Conductor Size	14 gauge	12 gauge
For each separate insulated wire	2 cu in	2.25 cu in
All ground wires (combined)	2 cu in	2.25 cu in
For each device (switch/receptacle)	4 cu in	4.5 cu in
All internal cable clamps (combined)	2 cu in	2.25 cu in

- 370  
 23. All electrical boxes shall be securely supported by the building structure.  
 25. In a completed installation, all outlet boxes shall have a cover, canopy for a lighting fixture, or device with an appropriate plate.  
 29. Do not conceal junction boxes in walls, ceilings, or non-accessible attics and under-floor areas.

- 404  
 2. Switches or circuit breakers shall not disconnect the grounded conductor of a circuit.  
 9. All electrical equipment, metal boxes, cover plates, and plaster rings shall be grounded. All switches, including dimmer switches, shall be grounded.

- 422  
 33. Cord connected, built-in kitchen appliances are allowed, but the receptacle must be accessible without removing the appliance.

**Electrical specifications**

**Part 1 - general**

- A. Scope  
 1. Finish and install a completely wired and operational electrical system as shown on the drawings and specified herein, including but not limited to, these major items.  
 A. Lighting fixtures as indicated and specified on the plans.  
 B. Electrical panels, controls, service, disconnects, conduit wiring, etc., for all outlets and equipment.  
 C. Telephone outlets and as indicated.  
 D. and outlets for alarm, computer, and security systems as indicated.  
 E. Control wiring for electrical systems.  
 2. Provide permits and inspections as required.  
 B. Codes, regulations and standards  
 1. The installation shall comply with applicable local and state codes and ordinances, with the regulations of the latest adopted edition of the following codes and with the requirements of the power and telephone companies furnishing services to this installation.  
 2. The following industry standards, specifications and codes are minimum requirements:  
 A. NEMA-national electrical manufacturer's association.  
 B. NEC-national electrical code.  
 C. UL-Underwriter Laboratories Incorporated standards  
 D. ANSI-american national standards institute  
 E. IEEE-institute of electrical and electronics engineers  
 F. NESC-national electrical safety code  
 C. Inspection of site  
 1. Prior to submitting a bid for electrical work, the electrical contractor shall visit the site of the proposed construction and shall thoroughly acquaint himself with existing utilities and working conditions to be encountered, etc. Allowance will not be made for non-compliance with this condition after bidding.  
 D. General workmanship  
 1. All work shall be executed and finished in a practical manner and shall present a neat and workmanlike appearance when completed.  
 2. All work must be acceptable to the owner. Where a detailed method of installing the work is not specified or indicated, install work as directed by the owner.  
 E. Related work by others  
 21. Electrical drawings identify utility service requirements for power, telephone, and cable tv within and up to five feet outside the building. Utility electrical service transformer(s), where shown on the site plan, are for information only and indicate the preferred point of service. Utility systems, pull boxes, and other structures, where shown on the site plan, are also for information only and indicated preferred routing. The electrical contractor shall refer to utility service drawings for actual utility service requirements for this project. Utility systems shall be constructed in accordance with the approved utility service drawings. It shall be the electrical contractor's responsibility to contact and follow-up with all utility companies to obtain both preliminary and final design drawings for this project.  
 A. The electrical contractor shall coordinate the installation of the electrical service entrance, meet all power company requirements, and shall pay all utility company charges.  
 B. The local telephone company will furnish and install all telephone wiring and equipment and will make all final telephone connections. The electrical contractor shall coordinate the installation of the telephone service entrance, meet all telephone requirements, and shall pay all utility company charges.  
 C. The electrical contractor shall coordinate the installation of the cable service entrance, meet all cable company requirements, and shall pay all utility company charges.  
 F. Cooperation with other contractors  
 1. Cooperate with the other trades so that the installation of the electrical outlets and equipment will be properly coordinated, fixtures, and other equipment locations shall be checked with the other trades to avoid conflict with the piping, ductwork, steel beams, or other obstructions.  
 2. Carefully check the locations of the outlet boxes and determine that they have not been disturbed during the installation of materials of other trades.  
 3. Coordinate the location of trenches and conduits for utility services and other disciplines with the general contractor.  
 G. Mechanical and electrical coordination  
 1. Any device which carries the full load current of the electrically driven machinery, as opposed to the control of instrumentation current in the holding coil, is a power circuit and is the responsibility of the electrical contractor. Control or instrumentation circuits connecting holding coils to the control system as specified by the mechanical engineer are the responsibility of the mechanical contractor.  
 2. The power circuit is defined as all devices necessary to operate, and as required by code to protect and service the unit, including branch circuit protective devices, disconnects, magnetic motor starters with running overload and single phasing protection, magnetic contactors, etc.  
 3. The control or instrumentation circuit is defined as all devices necessary to interface the electrical power circuit with the control system as specified by the mechanical engineer including boxes, fittings, conductors, electric-pneumatic switches, pneumatic-electric switches, electrical and pneumatic relays, pneumatic tubing, etc.  
 4. The electrical contractor shall be responsible to provide 120v duplex receptacles within 25 feet of all roof mounted equipment, per NEC 210.63.  
 H. Drawings  
 1. The drawings indicate the general arrangement and locations of the electrical work. Information presented on these drawings are as accurate as planning can determine, but field verification of all dimensions, locations, levels, etc., to suit field conditions is required. Review all architectural, structural, and mechanical drawings and adjust all work to meet the requirements of conditions shown. The architectural drawings shall take precedence over all other drawings. Discrepancies between different plans, or between drawings and specifications, or regulations and codes governing the installation shall be brought to the attention of the engineer in writing before the date of bid opening. Where discrepancies do exist, they shall reflect the most stringent requirements. The electrical contractor shall be responsible to field measure and confirm mounting heights and location of electrical equipment with respect to counters, etc. Do not scale distances off the electrical drawings. Use actual building dimensions.  
 2. Upon completion of the work under these drawings and specifications, the electrical contractor shall provide the owner with a complete set of marked-up electrical drawings showing the "as-built" condition of the work. Bond prints of the drawings required will be furnished by the owner, for this purpose.  
 3. All operating instructions, parts lists, and equipment manuals and equipment furnished and/or installed by the electrical contractor shall be turned over to the owner (three copies).  
 I. Shop drawings and approvals  
 1. Submittals shall consist of detailed shop drawings, specifications, block wiring diagrams, "catalog cuts" and data sheets containing physical and dimensional information, performance data, electrical characteristics, materials used in fabrication, and material finish. Clearly indicate by arrows or brackets precisely what is being submitted on and those optional accessories which are included and those optional accessories which are included and those which are excluded.  
 2. Each submittal shall be accompanied shall bear a stamp stating that the submittal must be thoroughly reviewed by the contractor and is in full compliance with the requirements of contract documents. Cover letters shall list in full the items and data submitted. Failure to comply with these requirements shall constitute grounds for rejection of data.  
 3. The contractor shall submit detailed drawings of all electrical equipment and generator rooms, yards, and utility areas. Minimum scale: 1/4"=1'-0".  
 4. As part of the equipment submittals, the manufacturer shall provide anchorage calculations for floor and wall mounted electrical equipment. Structural calculations shall be prepared and signed by registered structural engineer in California.  
 5. All resubmittals shall include a cover letter that lists the action taken and revisions made to every drawing and equipment data sheet in response to submittal review comments. Failure to include this cover letter will constitute rejection of the resubmittal package.  
 6. Contractor shall submit short circuit and coordination studies signed by a registered electrical engineer. Studies shall be performed in acceptance with IEEE guidelines. Contractor shall be submitted for architect-engineer review prior to ordering and installing any equipment. Contractor shall ensure that the actual feeder lengths match studies (revise studies if necessary). Service equipment markings as required per NEC 110.24 shall be based on contractor submitted studies.  
 7. Submit conduits; fittings; outlet pull and junction boxes; safety switches; fuses; transformers; panelboards; switchboards; circuit breakers; lighting control system/devices; and fire alarm systems.  
 J. Substitutions  
 1. All requests for substitutions shall conform to the general requirements and procedure outlined in division 1.  
 2. Where items are noted as "or equal", a product of equal design, construction and performance will be considered.  
 3. Substitutions shall be equal, in the opinion of the owner's representative, to the specified product.  
 4. The burden of proof of equality of a proposed substitution for a specified item shall be upon the electrical contractor. Electrical contractor shall support its request with sufficient test data, photometric analysis, detailed breakdown defining cost savings, and other means to permit the architect and/or engineer to make a fair and equitable decision on the merits of the proposed substitution. Any item by a manufacturer other than those specified, or of a brand name or model number will be considered a substitution. The architect and/or engineer will be the sole judge of whether or not the substitution is equal in quality, utility and economy to that specified.  
 5. Approval of a substitution shall not relieve electrical contractor from responsibility for compliance with all requirements of the contract documents. Electrical contractor shall bear the expense for any changes in other parts of this work or other work caused by the proposed substitution.  
 6. If architect and/or engineer rejects electrical contractor's substitute item on the first submittal, electrical contractor may make only one additional request for substitution in the same category.  
 K. Guarantee & testing  
 1. Guarantee all material furnished and all workmanship performed for a period of one year from the date of final acceptance of the work. Any defects developing within this period, traceable to material furnished as part of this section or workmanship performed hereunder, shall be corrected as necessary at no cost to the owner.  
 2. System shall be tested for proper operation. If test show that work is defective, electrical contractor shall make corrections as necessary at no cost to the owner.  
 L. Labeling  
 1. Provide engraved name plates on switchboards, panel boards, disconnect switches, motor control centers, transformers, etc., indicating equipment designated (or designation of equipment served) and voltage.  
 M. Housekeeping pads  
 1. Provide 4-inch-high concrete equipment pads for all floor-mounted equipment including switchboards, motor control center, transformers, etc.

**N. Materials**

1. All materials shall be new and of quality as specified on the plans or specifications and must carry the underwriter's laboratories approval covering the purpose for which they are used, in addition to meeting all recruitments of the current applicable codes and regulations.  
 2. Electrical contractor shall be responsible for replacing equipment which is damaged due to incorrect field wiring provided under this section or factory wiring in equipment provided under this section.  
 O. Storage and handling of material  
 1. Deliver materials and equipment to the project in the manufacturer's original, unopened, labeled containers. Protect against moisture, tampering, or damage from improper handling or storage. Electrical contractor shall protect and be responsible for any damage to work or materials until final acceptance by the owner, and shall arrange good storage for the owner, any damage or loss that may occur during this period.  
 2. Arrange for timely delivery of materials and equipment to the jobsite in order to minimize the length of time between delivery and installation.  
 3. Arrange for timely delivery of owner supplied materials and equipment to the jobsite in order to minimize the length of time between delivery and installation.  
 4. Cover and protect any material which may be affected by the weather while in transit or stored at the project site. Any material found defective or not installed in accordance with the contract documents may be rejected by the engineer.  
 5. No electrical work shall be installed in areas where other trades' work might cause physical damage to wires, equipment, boxes, or fittings until the other trade's work has been completed. Any equipment or materials which become damaged shall be removed and replaced at no extra cost to the owner.  
 P. Clean-up  
 1. Keep the premises free from accumulation of waste materials, or rubbish caused by employees or work under this division of the specifications. At the completion of the work, remove all surplus materials, tools, etc., and leave the premises "broom-clean".  
 Q. Excavation, cutting and fitting  
 1. Perform the excavation, cutting, fitting, repairing, and finishing of the work necessary for the installation of electrical equipment. However, no cutting of the work of other trades or of any structural member shall be done without the consent of the architect.  
 R. Excavation and backfill  
 1. Perform all excavation and backfilling required for work performed under this division of the specifications. Trench bottoms shall be graded true and free from stones or soft spots. Use excavated materials for backfill unless off site materials are deemed necessary by the architect. Trenching and backfilling for electrical and telephone utility services to building shall be provided by the electrical contractor in accordance with utility company requirements.  
 2. Verify location of existing underground utilities prior to trenching.

**Part 2 - products and execution**

- A. Conduit  
 a. Instead of using conduit, Non-Metallic sheathed cable (NM-B) may be used in residential applications in compliance with IRC allowable wiring methods  
 b. GRC may be used in all areas. IMC may be used in indoor locations not in contact with earth. EMT may be used in indoor locations not in contact with earth, not in concrete slabs or walls and not subject to damage. PVC may be used in or below concrete and direct buried in earth. Liquid-tight flexible steel conduit shall be for outdoor final connections to equipment not to exceed 36".  
 c. Cover metallic conduit in contact with earth or fill with polyethylene tape spiral wrapped, 1/2" lapped to provide double thickness. Tapes shall be Scotch no. 50 tape. Conduit and ducts not under buildings and feeder ducts shall be installed per NEC 300.5, except that the bends in conduit larger than 1" in diameter shall be made with galvanized steel conduit treated as noted above. Make joints with compound to be watertight.  
 d. Any installed conduit sizes shall be as required by code and as indicated or specified on drawings. No conduit smaller than 3/4-inch trade size shall be used.  
 e. Penetration through floor slabs where subject to damage shall be in wrapped rigid steel. Schedule 40 PVC elbows and penetrations may be used in slab on grade where penetrations occur in protected areas (walls, electrical rooms, etc.).  
 f. Conduits and outlets shall be concealed within the building structure, except that certain motor and lighting feeder conduits may be run exposed in certain areas as indicated on the drawings. Conduit shown to be installed in cabinets, counters, and casework shall be run as directed by the architect.  
 g. Any conduit serving roof mounted equipment and devices including HVAC equipment, GFCI maintenance receptacles and duct type smoke detectors shall be routed in the ceiling space. Conduit shall penetrate roof at equipment locations only no wiring or conduit shall be installed horizontally across roof surface.  
 h. Any flexible metallic and non-metallic conduit systems shall have a code sized copper ground conductor.  
 i. Any empty conduit systems shall have a 200-pound test pull cord installed to facilitate installation of future wire.  
 B. Fittings  
 1. EMT-fittings and conduit bodies shall be steel, malleable iron or die cast compression or set screw type.  
 2. IMC and GRC shall be steel or malleable iron type and shall engage a minimum of five (5) threads.  
 C. Outlet, pull and junction boxes  
 1. Pull and/or junction boxes shall be installed wherever shown on the drawings or as required by code.  
 2. Switch, Light, Receptacle, Junction, Pull and Outlet boxes shall be of the one-piece, knockout type, in general 4-inch square, 2 1/8-inch with plaster ring. Plaster rings shall be set to provide not more than 1/8" from wall surface to ring. In no case shall plaster ring project beyond surface of wall. Single gang rings similar to steel city 52050 shall be used for 4" boxes in unfinished brick. Number 180 boxes may be used for unfinished masonry flush wall outlets. Center all outlet boxes in block course.  
 3. Boxes installed in poured cement floors shall be flush type cast iron with watertight gasketed covers gray metallic finish. Where boxes are installed in floors with tile or carpet floor covering, covers shall be of the recessed type to accommodate the floor covering.  
 4. Boxes installed for the alarm, computer and security system shall be provided with appropriate cover plates.  
 5. Pull boxes shall be the types, size and design as approved by the NEC for the class of installation required.  
 6. Pull boxes and outlet boxes shall be sized by the electrical contractor as required by the NEC based on number of conductors, yokes, straps, etc., used in the installation.  
 D. Wire  
 1. Match building standards if applicable in an existing building condition, unless otherwise follow the specifications below.  
 2. Conductor size shown on the drawings based on copper wire. Unless otherwise specified, all wire shall be 75-degree c type thwn or xthwn. All branch circuit and feeder wiring shall be copper. Where raceway and cables exposed to direct sunlight on or above rooftops, provide type xhw-2 insulated conductors.  
 3. Wires shall be marked with color to simplify circuit identification. Unless otherwise required by local ordinances, identification shall be as follows:  
 A. 120/208v and 120/240v - phase a: black, phase b: red, phase c: blue, neutral: white, ground: green.  
 B. 277/480v - phase a: brown, phase b: orange, phase c: yellow, neutral: gray, ground: green.  
 4. The wire shall be #12 AWG unless otherwise indicated.  
 5. No wire shall be installed in a conduit system until the conduit system is complete. Use U.I. Approved lubricant to facilitate the installation of the conductors in the conduit system.  
 6. Conductors no. 10 AWG and smaller shall be solid. Conductors larger than no. 10 AWG shall be stranded.  
 7. MC cable is approved only for light fixture "whips" no longer than 6".  
 E. Wiring devices  
 1. Switches: wall switches shall be specification grade ac silent type switches 20ca, 120 - 277 volt, Hubbell 1221 (sp), 1222 (dp), 1223 (3-way) and 1224 (4-way). Dimmers shall be specification grade with reset slide control. Color shall be as approved by the architect/owner. Match building standard (if existing).  
 2. Receptacles: duplex type outlets shall be heavy duty, specification grade NEMA 5-20r, 20a, 120v grounded type equal to hubbell 5362. Isolated ground outlets shall be equal to hubbell ig5362. Special application receptacles shall be as indicated on plans and verified with equipment supplier. Color shall be as approved by the architect/owner. Match building standard (if existing).  
 3. Weatherproof receptacles: covers shall be hubbell wps26 with 5362 duplex outlet or equal.  
 4. GFCI receptacles: shall be hubbell g5362. GFCI receptacles shall be used in all outdoor applications as well as those placed within 6' of water source and all other NEC required locations.  
 5. Mounting heights: switches - +48 inches. Receptacles - +18 inches. Communication devices - +18 inches. Fire alarm devices - as required by ADA, NFPA 72 or authority having jurisdiction. All mounting heights are to centerline of device.  
 6. Device plates shall be equal to sierra smooth-line plastic wall plates. Color shall be as approved by the architect/owner. Match building standard (if existing).  
 7. In all cases, switches controlling lighting are to be located on the strike side of door. Locations indicated for switch and outlets are approximate. Owner may make minor relocations at no additional charge.  
 F. Lighting fixtures  
 1. Coordinate the final location of fixtures shown diagrammatically on the drawings with other trades in order to avoid interferences. Relocate fixtures as required as part of the work under this division if new location is within a five-foot radius of location shown.  
 2. Provide all lighting fixtures, wired and connected. The drawings indicating the fixtures for each location. Electrical contractor shall verify fixture locations, mounting requirements and U.I. Labeling of all fixtures prior to ordering. Include all accessories need for a complete installation including mounting clips, plaster frames, hangers, and hardware in base bid. Provide lamps for all fixtures. Verify ceiling construction before ordering recessed units.  
 3. Adjustable fixtures shall be located and properly aimed as directed by the architect or the lighting designer.  
 4. Support recessed fixture from ceiling structural support per adopted building codes.  
 5. All fixtures to bear the U.I. Label. All outdoor fixtures shall be U.I. Labeled for wet or damp location as defined by NEC article 100.

**G. Lamps**

1. Lamps shall be by the same manufacturer. Lamps shall be manufactured by GE, Philips, Ushio, Nichia, Samsung led or Cree.  
 2. Lamps shall be light emitting diode (led) type - minimum 80 cri indoors and 70 cri outdoors, 3500k (u.n.o.), 50,000 rated lamp hours. LEDs must be from the same manufacturer and batch.  
 H. Led drivers  
 1. Drivers shall be easily accessible without the use of special tools. Luminaires shall be capable of being operated by standard motion/vacancy sensors, daylight sensors, and dimmers. Dimming for 0-10 volt dc control circuits minimum. Drivers shall be specifically compatible with lighting control system being provided.  
 2. Temperature rating: +20 degrees Celsius minimum starting temperature. Luminaires accessories shall be able to range temperatures in excess of 110 degrees Fahrenheit design.  
 3. 90-percent minimum power factor, 50-60 hz frequency, total harmonic distortion less than 20-percent, led and driver life expectancy of 50,000 minimum projected hours at 6,000 hours testing for both LEDs and drivers; luminaires in contact with insulation material shall be ic rated; rated for dry and damp locations.  
 4. Approved driver manufacturers include Osram, Philips, Kenall, Eldolee, general electric, and other only if approved.  
 I. Safety switches  
 1. Safety switches shall be general duty type, 250 volt for 208 volt equipment and heavy duty type, 400 volt for 480 volt equipment. Safety switches shall have the number of poles required. Wire terminations shall be listed as specified by the NEC. Safety switches for air conditioning use shall be of the fusible type where recommended by equipment manufacturer. Fusible switches shall accept class 'Y' fuses only and will reject all other types. The switch size, number of poles and voltage rating shall be as required by code and as indicated on the drawings. Where outside the building, the switches shall be type NEMA 3r weatherproof. All switches shall be lockable.  
 2. Provide dymo-tape tag inside cover of each fusible switch, indicating size and type of fuses provided.  
 J. Fuses  
 1. Fuses shall be dual element time delay type, as manufactured by bussman mfg. Company, or as indicated or required by equipment supplied.  
 2. Provide two (2) sets of three (3) spare fuses for each size and type provided on this project. Install fuses in a hinged door, sheet metal storage cabinet equipment with clips or cubicles, each marked with size and type of fuse stored therein. Provide nameplate "spare fuses," install in location as directed by owner.  
 K. Service entrance  
 1. The service entrance equipment size, voltage and rating shall be as indicated on the drawings. Provide copper wiring unless otherwise noted or permitted. Equipment shall carry the u.I. Label and shall conform to the power company regulations.  
 2. Electrical contractor is responsible to verify and confirm that equipment submitted shall fit within the allotted space requirements shown on the plans. Drawings indicate maximum dimensions for the switchboards including clearances between switchboards on adjacent surfaces and other items. Comply with maximum dimensions. If any space or size discrepancies are anticipated, it is the electrical contractor's responsibility to notify the engineer prior to submittal. Once the submittals have been approved it is the electrical contractor's responsibility to install the equipment in the space allotted space at no additional cost to the owner.  
 3. Service entrance equipment shall be manufactured by general electric, square d, cutter-hammer, siemens or approved equal.  
 4. All overcurrent protection devices and electrical distribution equipment shall be fully (100%) rated for available fault current indicated. Series rated devices are note acceptable.  
 L. Transformers  
 1. Transformers shall be dry type with copper windings. 115-degree temperature rise, and doe10 cfr part 431 appendix c table 431.201. Energy efficiency under doe 2016 requirements it to be energy verified by u.I.  
 2. All transformers shall be provided with class 220-degree Celsius insulation system and shall be completely enclosed except for ventilation openings.  
 3. Transformers shall be 115-degree temperature rise above 40-degree Celsius ambient temperature. 4. Transformers shall be equipped with 2-1/2% (2 above and 2 below normal voltage) primary taps.  
 M. Panelboards  
 1. Circuit breaker type as indicated on drawings. All panels shall have panelboard type construction with bolt-on circuit breakers. Panels installed as load centers shall include bonding jumpers, sized according to the applicable provisions of the NEC. Busing shall be copper unless otherwise noted or permitted.  
 2. Manufacturers shall be general electric, square d, cutter-hammer, siemens with voltage, sizes and rating as indicated on drawings. All panelboards in the facility shall be by the same manufacturer.  
 3. The circuit breakers shall be operable in any position and be removable from the front of the panelboard without disturbing the adjacent units. Branch breakers shall be of such design that combination of single-pole, double-pole and three-pole breakers can be assembled on the same panel. Each branch circuit shall be clearly numbered. Branch and main terminals shall be of the solderless type. Handle ties to form multi-pole breakers are note acceptable.  
 4. Wire termination for panelboards, load centers and circuit breakers shall be listed as specified by the NEC.  
 5. Provide a printed circuit index behind clear plastic cover on inside of door. Information shall include room and type of load served. All circuit breakers shall be identified, including spares. Index card frame shall be metal, secured to door.  
 7. Where panelboards are installed flush with the walls, extend empty conduits from the panelboard to an accessible space above or below. Provide 3/4" (minimum size) conduit for every three single spare circuit breakers or space or accommodate multi-pole arrangement, or fraction thereof, but not less than two conduits for each panelboard.  
 N. System grounding  
 1. Grounding shall comply with requirements of article 250. All exposed noncurrent-carrying metallic parts of electrical equipment, metallic raceway systems, metallic cable armor, grounding conductor of nonmetallic sheathed cables, grounding conductor in nonmetallic raceways, and grounded conductors of the wiring system shall be grounded.  
 2. The grounded conductor (neutral) of the wiring system shall be connected to the system grounding conductor at a single place in each system by removable bonding jumpers, sized according to the applicable provisions of the NEC. The grounded conductor (neutral) to the grounding conductor connection shall be located in the enclosure for the system's overcurrent protection or where otherwise indicated on the plans or specifications.  
 3. Ground bus separate from the neutral bus shall be provided in all switchboards and panelboards. Ground bus shall be retorque (checked) prior to energizing equipment per manufacturer's recommendations.  
 4. Ground buses and neutral buses in all distribution panels, switchboards, panelboards and those provided in any equipment shall be isolated except where required to be connected as specified above for the service entrance and in transformer terminal compartments.  
 5. When indicated on the drawings, equipment grounding conductors shall be extended from the ground bus in the distribution equipment to the receptacle, fixture or device jugs where they are provided. When not provided, they shall be connected to equipment enclosures. The connection shall be arranged such that removal of the receptacles, the equipment ground conductors, or the ground jumpers from ground busing shall not affect the ground system.  
 6. Raceways may not be used as a grounding conductor for power and lighting circuits. Every conduit supplying power and lighting circuits shall have a separate code sized green ground wire installed in the conduit to ensure a continuous grounding path.  
 7. In inaccessible locations make connections by exothermic weld process.  
 8. In accessible locations, connection shall be made with approved bolted bronze grounding devices.  
 O. Equipment connections  
 1. All motors shall be wired to conform with manufacturer's recommendations and with applicable codes. Furnish necessary materials, such as wire, fittings, etc. Required to connect motor. However, motors, controls, etc. shall be furnished by the supplier of the driven equipment. Verify equipment location and sizes with the trade supplying the motor before installing the wiring or outlets.  
 2. Final connection to all HVAC or motor loads from load side of disconnect shall be made using copper wire only, aluminum wire is not acceptable.  
 P. Communication systems  
 1. For all communication outlets provide double gang back box with single gang plaster ring. Provide blank cover plates for all unused boxes.  
 2. Provide 3/4" fire rated plywood for telephone terminal.

**ELECTRICAL LAYOUT AND DESIGN IS DELEGATED TO SUBCONTRACTOR. SUBMIT LAYOUT FOR REVIEW AND COORDINATION WITH OTHER TRADES**

**PROVIDED ELECTRICAL PLAN IS FOR BIDDING REFERENCE ONLY**

**TriArch**  
 Purpose. Driven. Architecture.  
 618 E. 3rd St.  
 Tulsa, OK 74103  
 918.243.2264 (M)  
 918.243.2279 (F)

No.	Description	Date

REVISIONS

Consultants

**SINGLE FAMILY HOME  
 3 BR ADA HOME**

HOUSING AUTHORITY OF  
 THE CHEROKEE NATION  
 N. SHERIDAN RD. & E. 136TH ST. N.  
 COLLINSVILLE, OK

Key Plan

STATE OF OKLAHOMA  
 WESTON VICKO  
 No. 8292  
 License  
 ARCHITECT

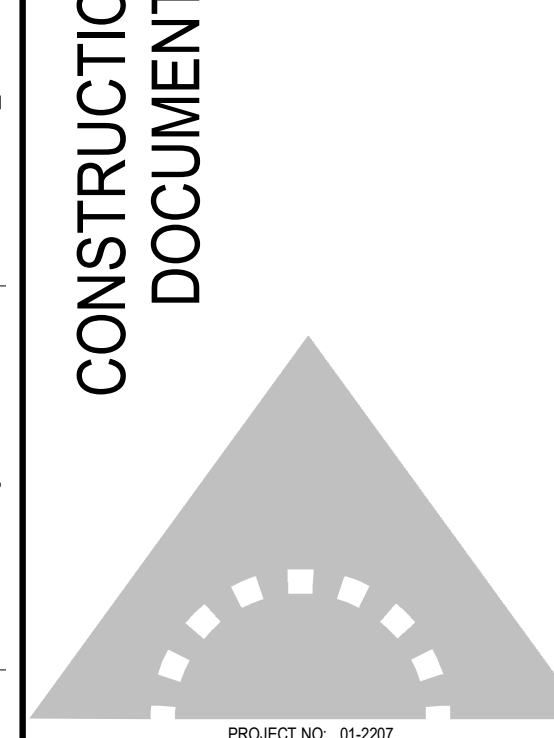

SHEET TITLE: **ELECTRICAL SPECIFICATIONS**

DRAWN BY: Author  
 CHECKED BY: Checker  
 ISSUE DATE: 2 -14-2022

**G004**

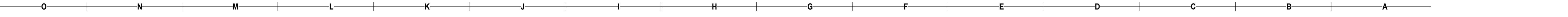

THIS DOCUMENT AND DESIGN INCORPORATED HEREIN ARE THE PROPERTY OF TRIARCH AND ARE NOT TO BE REPRODUCED, COPIED, OR OTHERWISE USED FOR ANY OTHER PROJECT WITHOUT THE WRITTEN AUTHORIZATION OF TRIARCH.





No.	Description	Date

REVISIONS

Consultants

**SINGLE FAMILY HOME  
3 BR ADA HOME**

HOUSING AUTHORITY OF  
THE CHEROKEE NATION

N. SHERIDAN RD. & E. 136TH ST. N.  
COLLINSVILLE, OK

Key Plan

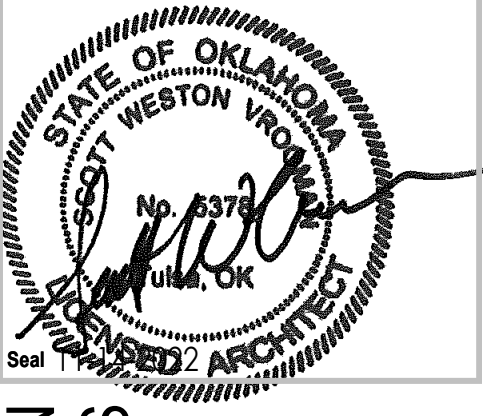

**CONSTRUCTION DOCUMENTS**

PROJECT NO. 01-2207

SHEET TITLE: **GENERAL NOTES**

DRAWN BY: Author  
CHECKED BY: Checker  
ISSUE DATE: 2 -14-2022

**S001**

# GENERAL NOTES

## DESIGN PARAMETERS

- BUILDING CODE:** 2015 INTERNATIONAL RESIDENTIAL CODE
  - DEAD LOADS:**
    - ROOF: 20 PSF (UNIFORM)
  - LIVE LOADS:**
    - ROOF: 20 PSF (UNIFORM)
  - SNOW LOADS:**
    - GROUND SNOW LOAD, P<sub>g</sub>: 10 PSF
  - WIND LOADS:**
    - BASIC WIND SPEED (3 SECOND GUST): 115 MPH
    - EXPOSURE CLASSIFICATION: C
    - INTERNAL PRESSURE COEFFICIENT: 0.18
    - IMPORTANCE FACTOR: 1.0
  - SEISMIC LOADS:**
    - SPECTRAL RESPONSE ACCELERATION (SHORT PERIOD), S<sub>s</sub>: 0.181
    - SPECTRAL RESPONSE ACCELERATION (1-SEC. PERIOD), S<sub>1</sub>: 0.063
    - SPECTRAL RESPONSE COEFFICIENT (SHORT PERIOD), S<sub>ds</sub>: 0.193
    - SPECTRAL RESPONSE COEFFICIENT (1-SEC. PERIOD), S<sub>d1</sub>: 0.100
  - SITE CLASS:** D
  - IMPORTANCE FACTOR:** I: 1.0
  - SEISMIC DESIGN CATEGORY:** B
  - BASIC STRUCTURAL SYSTEM AND SEISMIC RESISTING SYSTEM:** LIGHT FRAME WOOD WALL WITH STRUCTURAL WOOD SHEAR PANEL
  - RESPONSE MODIFICATION FACTOR, R:** 7
  - K SYSTEM OVER-STRENGTH FACTOR, W:** 2.5
  - DEFLECTION AMPLIFICATION FACTOR, C<sub>d</sub>:** 4.5
  - ANALYSIS PROCEDURE:** EQUIVALENT LATERAL FORCE
8. **FOUNDATIONS:**  
ISOLATED AND CONTINUOUS FOOTINGS BEARING ON APPROVED NATIVE SOILS OR STRUCTURAL FILL HAVE BEEN DESIGNED FOR AN ALLOWABLE NET BEARING PRESSURE OF 1,800 PSF PER THE RECOMMENDATIONS PROVIDED IN THE REFERENCED GEOTECHNICAL REPORT.

## DIVISION 3 - CONCRETE

- ALL CONCRETE SHALL CONFORM TO THE SPECIFICATIONS FOR STRUCTURAL CONCRETE, ACI 301.
- CONTRACTOR SHALL FOLLOW ACI 308.1 FOR COLD WEATHER CONCRETE PLACEMENT AND CURING GUIDELINES.
- ARRANGEMENTS AND DETAIL OF REINFORCING BENDS SHALL BE IN ACCORDANCE WITH THE LATEST EDITION OF PUBLICATION SP-86, "ACI DETAILING MANUAL" AND ACI 318, "BUILDING CODE REQUIREMENTS FOR STRUCTURAL CONCRETE."
- UNLESS NOTED OTHERWISE, BAR SPLICES SHALL BE CLASS B TENSION LAPS AND SHALL BE LAPPED WITH MINIMUM LENGTHS AS LISTED IN THE LAP LENGTH SCHEDULE, WHERE REQUIRED IN REINFORCING. SHORTER LAPS MAY BE ACCEPTABLE IF SPECIFIC LOCATIONS OF ALTERNATE LAPS ARE SHOWN ON THE REINFORCING PLACEMENT DRAWINGS AND CALCULATIONS ARE SUBMITTED BY A REGISTERED PROFESSIONAL ENGINEER, LICENSED TO PRACTICE IN THE STATE IN WHICH THE PROJECT IS LOCATED, JUSTIFYING THE ALTERNATE LAP LENGTHS.
- PROVIDE SUITABLE WIRE SPACERS, CHAIRS, TIES, ETC. FOR SUPPORTING REINFORCING STEEL IN THE PROPER POSITION BEFORE PLACING CONCRETE. DO NOT "WET STICK" DOWELS.
- ALL WELDED WIRE FABRIC SHALL BE LAPPED A MINIMUM OF 12" AT THE SIDES AND ENDS.
- LOCATIONS AND SIZES OF OPENINGS, SLEEVES, ETC. REQUIRED FOR OTHER TRADES MUST BE VERIFIED BY THESE TRADES BEFORE PLACING CONCRETE.
- ALL SLOTS, SLEEVES, TRENCHES AND OTHER EMBEDDED ITEMS SHALL BE SET AND SECURED AGAINST MOVEMENT BEFORE THE CONCRETE IS PLACED. SEE ARCHITECTURAL, ELECTRICAL, MECHANICAL, PLUMBING, AND VENDOR DRAWINGS FOR SIZES, AND LOCATIONS. COORDINATE LOCATIONS, SPACINGS, AND SIZES WITH THE STRUCTURAL ENGINEER OF RECORD PRIOR TO PLACING CONCRETE.
- AS PART OF THE SUBMITTAL PROCESS, THE ELECTRICAL AND MECHANICAL CONTRACTOR(S) SHALL SUBMIT PROPOSED ROUTING PLAN FOR ALL PIPES, CONDUITS, OR OTHER DEVICES TO BE EMBEDDED IN THE CONCRETE. THE SUBMITTAL SHALL SHOW SPECIFIC SIZES AND LOCATIONS OF ALL PROPOSED EMBED ITEMS REFERENCING PROXIMITY TO BEAM, COLUMN, AND SLAB EDGES. NO ITEMS SHALL BE ALLOWED TO BE EMBEDDED IN THE CONCRETE WITHOUT PRIOR WRITTEN APPROVAL FROM THE STRUCTURAL ENGINEER OF RECORD.
- CONDUITS AND PIPES EMBEDDED IN CONCRETE SLABS MAY BE NO LARGER THAN 1/3 OF THE SLAB THICKNESS (BASED ON THE MAXIMUM OUTSIDE DIAMETER) AND SHALL HAVE A CENTER-TO-CENTER SPACING NO LESS THAN THREE (3) CONDUIT DIAMETERS. REGARDLESS OF DIAMETER, THE MINIMUM CLEAR SPACING BETWEEN CONDUITS OR REINFORCING SHALL BE (1) INCH.
- NO MORE THAN FOUR CONDUITS MAY BE PLACED ADJACENT TO EACH OTHER WITHOUT PRIOR APPROVAL IN WRITING FROM THE STRUCTURAL ENGINEER OF RECORD.
- NO ALUMINUM CONDUITS, DEVICES, OR FIXTURES MAY BE EMBEDDED INTO THE CONCRETE SO THAT THE ALUMINUM IS IN DIRECT CONTACT WITH THE CONCRETE.
- CORNER BARS SHALL BE PROVIDED FOR ALL HORIZONTAL REINFORCING BARS AT THE INTERSECTIONS AND CORNERS OF ALL STRIP FOOTINGS, BEAMS, AND WALLS UNLESS NOTED OTHERWISE. CORNER BARS SHALL BE OF THE SAME SIZE AND GRADE AS THE HORIZONTAL REINFORCING THEY CONNECT. MINIMUM LAP LENGTHS SHALL BE AS INDICATED ABOVE UNLESS NOTED OTHERWISE.
- FOR EXTERIOR RETAINING WALLS AND BUILDING STEM WALLS EXPOSED TO VIEW ACROSS THE LENGTH OF WALL, PROVIDE FORMED "V" CONTROL JOINTS AT 15'-0" OC MAX.

LAP LENGTHS FOR SPLICES		
BAR SIZE	TOP BARS**	OTHER
#3	1'-5"	1'-4"
#4	1'-11"	1'-5"
#5	2'-4"	1'-10"
#6	2'-10"	2'-2"
#7	4'-7"	3'-7"
#8	5'-10"	4'-6"
#9	7'-2"	5'-6"

\* BASED ON MINIMUM CONCRETE COVER OF 1 1/2". A MINIMUM CENTER-TO-CENTER BAR SPACING OF THREE BAR DIAMETERS, AND 3,000 PSI CONCRETE.

\*\* TOP BARS ARE HORIZONTAL BARS WITH MORE THAN (12) INCHES OF CONCRETE CAST BELOW BARS.

REQUIRED CONCRETE STRENGTHS (28 DAY)	
CONCRETE ELEMENT	f <sub>c</sub> (PSI)
FOOTINGS AND STEM WALLS	3,000
FOUNDATION WALLS AND PEDESTALS	4,000
INTERIOR SLABS-ON-GRADE	3,500
SLABS ON COMPOSITE DECK	3,000
STEEL STAIR FANS (SLABS ON NON-COMPOSITE DECK)	3,000
BUILDING FRAME MEMBERS	4,000
BUILDING WALLS	4,000
EXTERIOR EXPOSED CONCRETE (AIR ENTRAINED)	4,500

REINFORCEMENT MATERIALS			
REINF ELEMENT	ASTM	F <sub>y</sub> (KSI)	F <sub>u</sub> (KSI)
TYP REINFORCING	A615	60	90
WELDED AND BENT REINF	A706	60	80
WELDED WIRE REINFORCING, SMOOTH	A185	65	75
WELDED WIRE REINFORCING, DEFORMED	A497	70	80

REINFORCEMENT COVER REQUIREMENTS	
LOCATION	COVER (IN)
COLUMNS, GIRDERS, AND BEAMS	1 1/2
CONCRETE CAST AGAINST EARTH	3
CONCRETE CAST IN FORMS, EXPOSED TO WEATHER OR EARTH	2
CONCRETE CAST ON VOID FORMS WITH MASONITE OR PLYWOOD COVERING	2
JOISTS	1 1/2
SLABS OR WALLS NOT EXPOSED TO EARTH OR WEATHER	1

## GENERAL

- STRUCTURAL DRAWINGS ARE NOT STAND-ALONE DOCUMENTS AND ARE INTENDED TO BE USED IN CONJUNCTION WITH CIVIL, ARCHITECTURAL, MECHANICAL, ELECTRICAL, AND DRAWINGS FROM OTHER DISCIPLINES. THE CONTRACTOR SHALL COORDINATE ALL REQUIREMENTS OF THE CONTRACT DOCUMENTS INTO THE SHOP DRAWINGS AND FIELD WORK.
- WHERE CONFLICT EXISTS AMONG VARIOUS PARTS OF THE STRUCTURAL CONTRACT DOCUMENTS, STRUCTURAL DRAWINGS, GENERAL NOTES, AND SPECIFICATIONS, THE STRICTEST REQUIREMENTS, AS INDICATED BY THE ENGINEER, SHALL GOVERN.
- ALL STRUCTURAL ELEMENTS OF THE PROJECT HAVE BEEN DESIGNED BY THE STRUCTURAL ENGINEER TO RESIST THE REQUIRED CODE VERTICAL AND LATERAL FORCES THAT COULD OCCUR IN THE FINAL COMPLETED STRUCTURE ONLY. IT IS THE RESPONSIBILITY OF THE CONTRACTOR TO PROVIDE ALL REQUIRED BRACING DURING CONSTRUCTION TO MAINTAIN THE STABILITY AND SAFETY OF ALL STRUCTURAL ELEMENTS DURING THE CONSTRUCTION PROCESS UNTIL THE LATERAL LOAD RESISTING OR STABILITY-PROVIDING SYSTEM IS COMPLETELY INSTALLED AND THE STRUCTURE IS COMPLETELY TIED TOGETHER.
- THE STRUCTURE HAS BEEN DESIGNED FOR THE LOADS IDENTIFIED WITHIN THESE STRUCTURAL DRAWINGS THAT ARE ANTICIPATED TO BE APPLIED TO THE FINAL STRUCTURE ONE COMPLETED AND OCCUPIED. THE CONTRACTOR SHALL NOT OVERLOAD THE STRUCTURE DURING CONSTRUCTION. THE CONTRACTOR SHALL BE RESPONSIBLE FOR CHECKING THE ADEQUACY OF THE STRUCTURE TO SUPPORT ANY APPLIED CONSTRUCTION LOADS, INCLUDING THOSE DUE TO CONSTRUCTION VEHICLES OR EQUIPMENT, MATERIAL HANDLING OR STORAGE, SHORING AND RESHORING, OR ANY OTHER PROPOSED CONSTRUCTION LOADS THAT ARE IN EXCESS OF THE STATED DESIGN LOADS. THE STRUCTURAL ENGINEER IS NOT RESPONSIBLE TO DESIGN OR CHECK THE STRUCTURE FOR LOADS APPLIED TO THE STRUCTURE FOR ANY CONSTRUCTION ACTIVITY.
- WEIGHTS OF MECHANICAL EQUIPMENT SHOWN ON THE STRUCTURAL PLANS ARE FOR UNITS SPECIFIED BY THE MECHANICAL ENGINEER. CONTRACTOR SHALL VERIFY WEIGHTS AND ANY SUBSTITUTIONS THAT RESULT IN INCREASED WEIGHT SHALL BE APPROVED BY THE STRUCTURAL ENGINEER OF RECORD.
- THE SIZE AND LOCATION OF EQUIPMENT PADS AND PENETRATIONS THROUGH THE STRUCTURE FOR MECHANICAL, ELECTRICAL, AND PLUMBING WORK SHALL BE VERIFIED BY THE CONTRACTOR. OPENINGS AND PENETRATIONS NOT SPECIFICALLY SHOWN ON THE STRUCTURAL DRAWINGS SHALL BE SUBJECT TO APPROVAL BY THE STRUCTURAL ENGINEER OF RECORD.
- PRIOR TO FABRICATION AND/OR ERECTION OF ANY MATERIALS, THE CONTRACTOR SHALL FIELD VERIFY ALL PERTINENT EXISTING DIMENSIONS, ELEVATIONS, AND CONDITIONS AND SHALL REPORT ANY DISCREPANCIES TO THE STRUCTURAL ENGINEER OF RECORD OR THE ARCHITECT IMMEDIATELY UPON DISCOVERY.
- ANY MATERIALS OR PRODUCTS SUBMITTED FOR APPROVAL THAT ARE DIFFERENT FROM THE MATERIAL OR PRODUCTS SPECIFIED IN THE STRUCTURAL CONTRACT DOCUMENTS WILL BE APPROVED ONLY IF THE FOLLOWING CRITERIA ARE SATISFIED:
  - A COST SAVINGS TO THE OWNER IS DOCUMENTED AND SUBMITTED WITH THE REQUEST.
  - THE MATERIAL OR PRODUCT HAS BEEN APPROVED BY THE INTERNATIONAL CODE COUNCIL (ICC) AND THE ICC REPORT IS SUBMITTED WITH THE REQUEST.
- THE ENGINEER SHALL NOT HAVE CONTROL NOR CHARGE OF, AND SHALL NOT BE RESPONSIBLE FOR, CONSTRUCTION MEANS, METHODS, TECHNIQUES, SEQUENCES, OR PROCEDURES, FOR SAFETY PRECAUTIONS AND PROGRAMS IN CONNECTION WITH THE WORK. FOR THE ACTS OR OMISSION OF THE CONTRACTOR, SUBCONTRACTOR, OR ANY OTHER PERSONS PERFORMING ANY OF THE WORK, OR FOR THE FAILURE OF ANY OF THEM TO CARRY OUT THE WORK IN ACCORDANCE WITH THE CONTRACT DOCUMENTS.
- PERIODIC SITE OBSERVATION BY FIELD REPRESENTATIVES OF 360 ENGINEERING GROUP, LLC, IS SOLELY FOR THE PURPOSE OF BECOMING GENERALLY FAMILIAR WITH THE PROGRESS AND QUALITY OF THE WORK COMPLETED AND DETERMINING, IN GENERAL, IF THE WORK OBSERVED IS BEING PERFORMED IN A MANNER INDICATING THAT THE WORK, WHEN FULLY COMPLETED, WILL BE IN ACCORDANCE WITH THE STRUCTURAL CONTRACT DOCUMENTS. THIS LIMITED SITE OBSERVATION SHOULD NOT BE CONSTRUED AS EXHAUSTIVE OR CONTINUOUS TO CHECK THE QUALITY OR QUANTITY OF THE WORK, BUT RATHER PERIODIC IN AN EFFORT TO GUARD THE OWNER AGAINST DEFECTS OR DEFICIENCIES IN THE WORK OF THE CONTRACTOR.

## FOUNDATIONS

- FOOTINGS SHALL BEAR EITHER ON COMPETENT NATIVE SOIL OR COMPACTED STRUCTURAL FILL.
- EXTERIOR PERIMETER FOOTINGS SHALL BEAR NOT LESS THAN 24 INCHES BELOW FINISH GRADE UNLESS OTHERWISE SPECIFIED BY A GEOTECHNICAL ENGINEER AND/OR BUILDING OFFICIAL. IF THE SOIL AT THE BEARING ELEVATIONS SHOWN IS OF QUESTIONABLE BEARING VALUE, THE STRUCTURAL ENGINEER OF RECORD OR ARCHITECT SHALL BE NOTIFIED IMMEDIATELY.
- PROVIDE A MINIMUM OF A 4-INCH CLEAN, FREE-DRAINING GRANULAR SUBBASE FILL BELOW ALL INTERIOR SLABS-ON-GRADE UNLESS NOTED OR DETAILED OTHERWISE. SUBBASE SHALL MEET GRADATION REQUIREMENTS OF ASTM C-33 SIZE NO. 67, UNLESS SPECIFICALLY NOTED OTHERWISE.
- A 15-MIL MINIMUM POLYETHYLENE FILM VAPOR RETARDER, MEETING THE REQUIREMENTS IN THE SPECIFICATIONS, SHALL BE PLACED BELOW ALL INTERIOR SLABS-ON-GRADE.
- THE CONTRACTOR IS CAUTIONED AGAINST LOADING SLAB-ON-GRADE WITH CONSTRUCTION EQUIPMENT. THE SLAB HAS NOT BEEN DESIGNED FOR CONSTRUCTION EQUIPMENT AND MAY REQUIRE AN INCREASE IN SLAB THICKNESS AND/OR REINFORCEMENT. IF THE CONSTRUCTION LOADING EXCEEDS THE DESIGN LOADS SHOWN IN THE DESIGN CRITERIA, THE CONTRACTOR IS REQUIRED TO SUBMIT CALCULATIONS SIGNED AND SEALED BY A REGISTERED STRUCTURAL, CIVIL, OR GEOTECHNICAL ENGINEER IN THE STATE WHERE THE PROJECT IS LOCATED VERIFYING THE ADEQUACY OF THE SLAB.
- EXTERIOR FOOTINGS FOR STAIRS AND RAMPS SHALL BEAR AT OR BELOW MINIMUM BEARING DEPTH.
- FOUNDATION WALLS SHALL HAVE ADEQUATE TEMPORARY BRACING INSTALLED BY THE CONTRACTOR BEFORE BACKFILL IS PLACED AGAINST THEM. TEMPORARY BRACING SHALL NOT BE REMOVED UNTIL WALL IS PERMANENTLY BRACED.

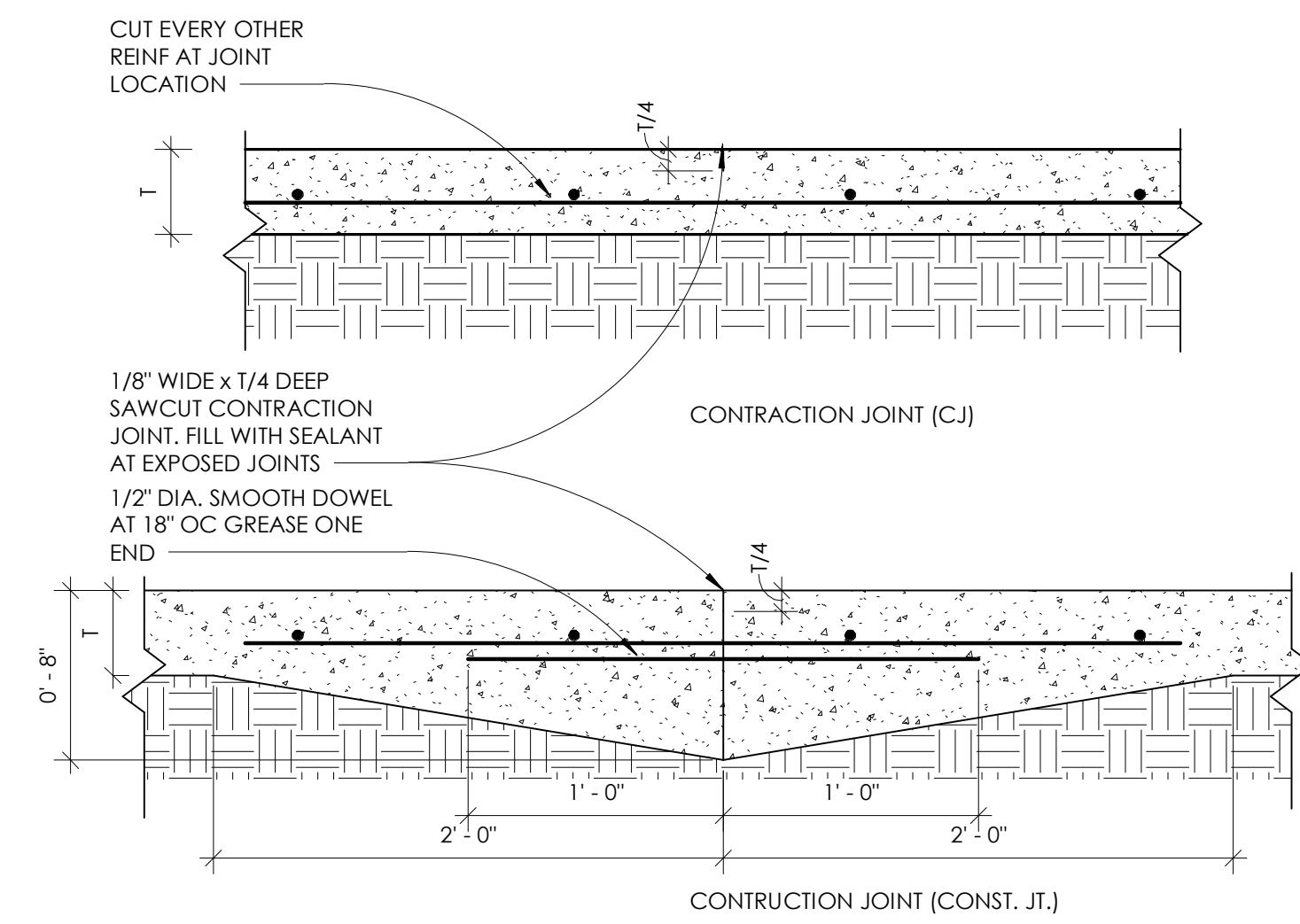

- NOTES:**
- SEE FOUNDATION PLAN FOR ADDITIONAL SLAB INFORMATION, INCLUDING DEPTH AND REINFORCING
  - THE SAWCUTTING SHOULD BE DONE AS SOON AS THE CONCRETE HAS HARDENED SUFFICIENTLY TO PERMIT CUTTING W/O CHIPPING, SPALLING OR TEARING BUT NOT MORE THAN 8 HOURS AFTER CASTING
  - DOWELS SHALL BE APARALLEL TO THE SLAB'S TOP SURFACE AND PERPENDICULAR TO THE SLAB JOINT. DOWELS SHALL BE A MINIMUM OF 6" FROM ANY SLAB EDGE.

**4** JOINT DETAILS  
1 1/2" = 1'-0"

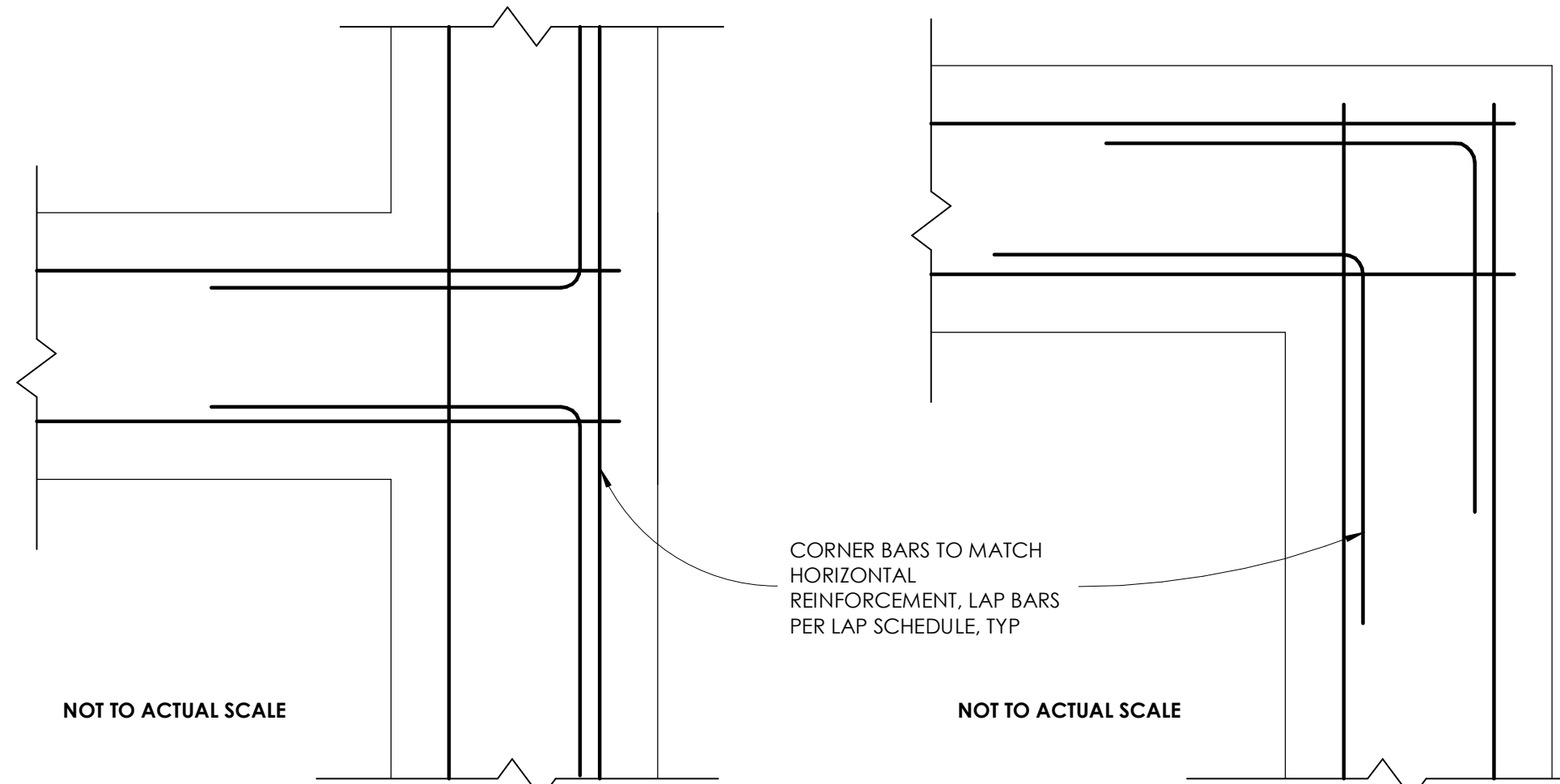

**3** DETAIL CORNER BAR DETAILS  
1 1/2" = 1'-0"

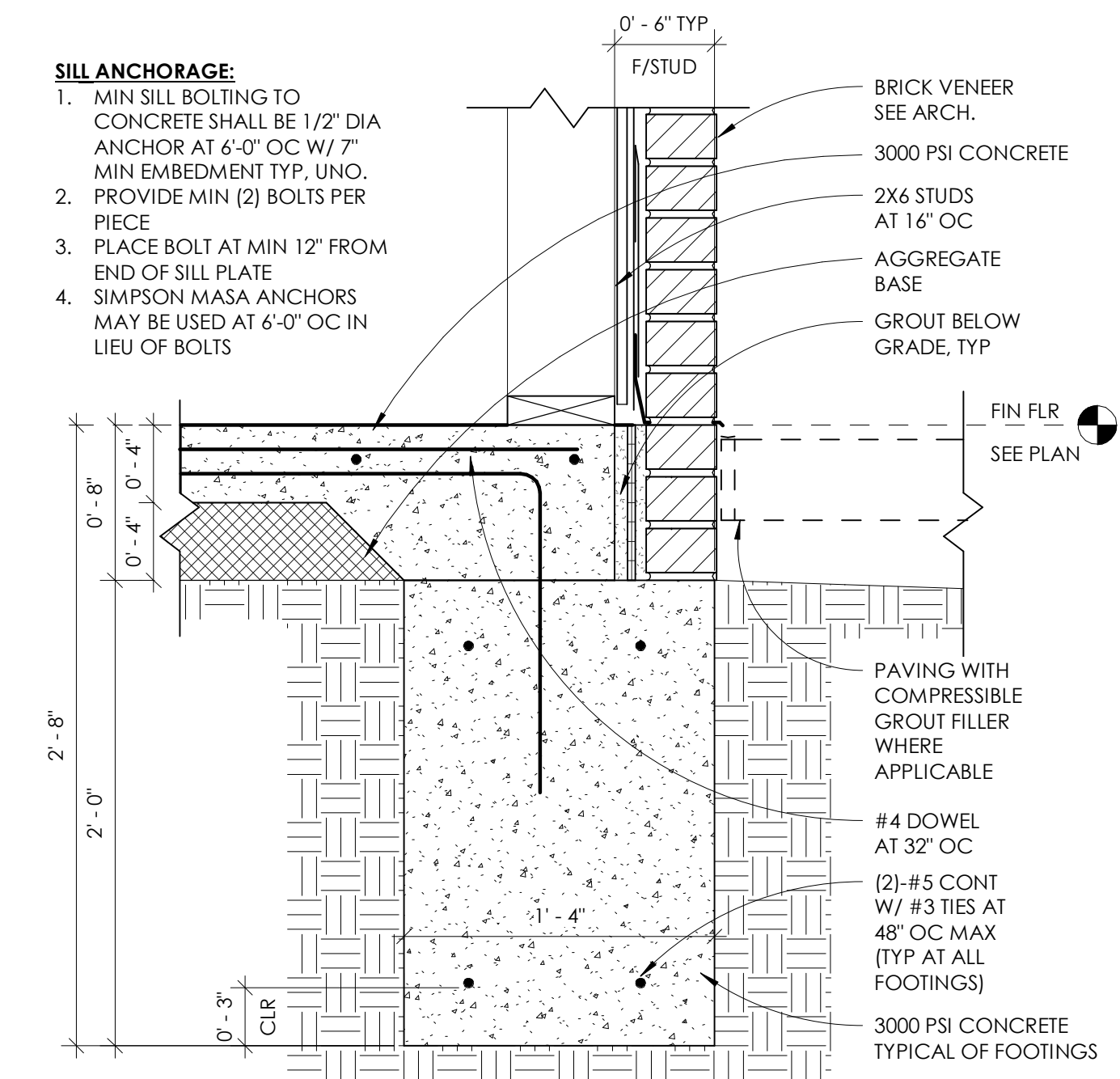

**2** TYPICAL PERIMETER FOOTING DETAIL  
1 1/2" = 1'-0"

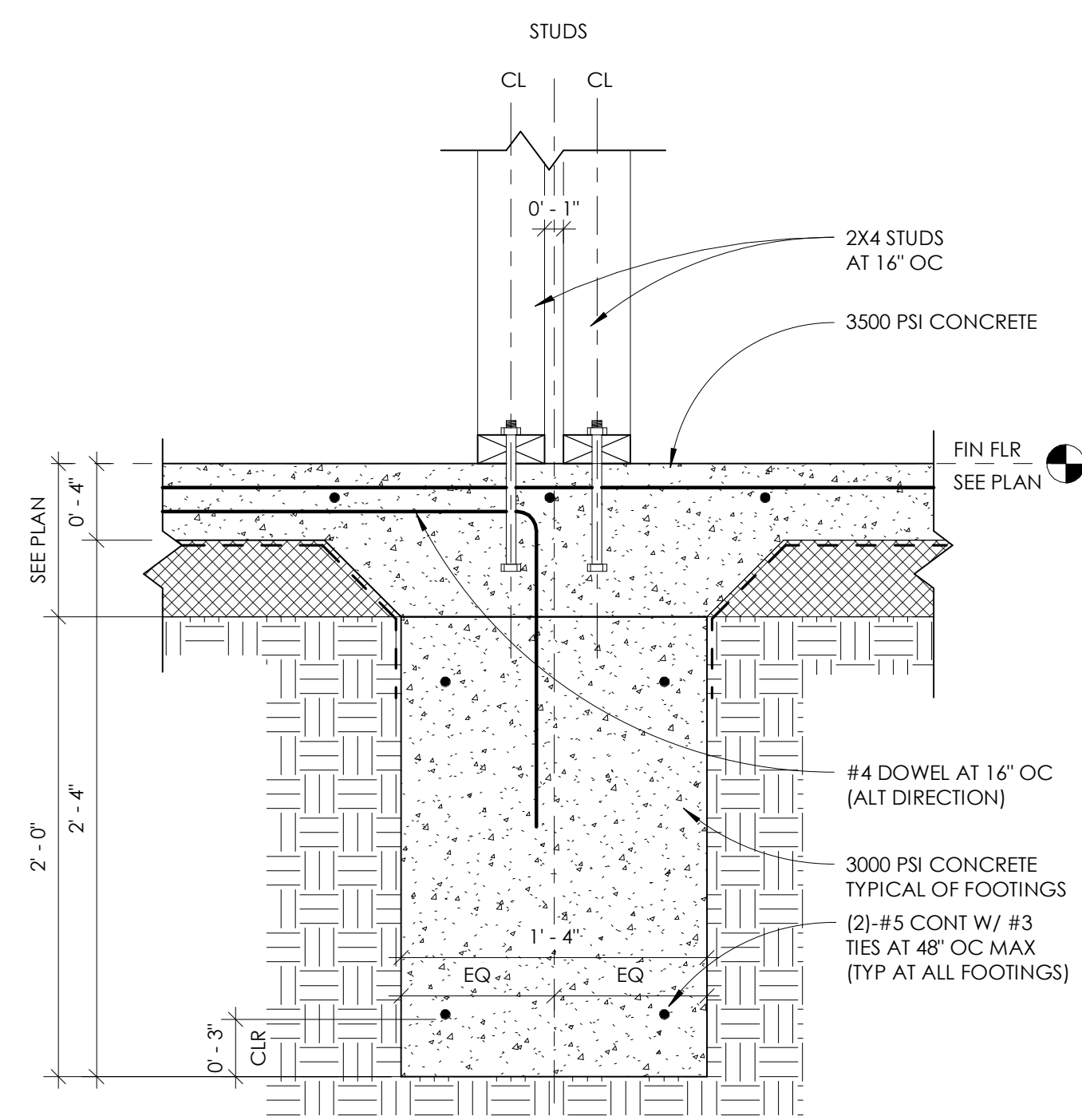

**6** TYPICAL INTERIOR DIVIDING WALL FOOTING DETAIL  
1 1/2" = 1'-0"

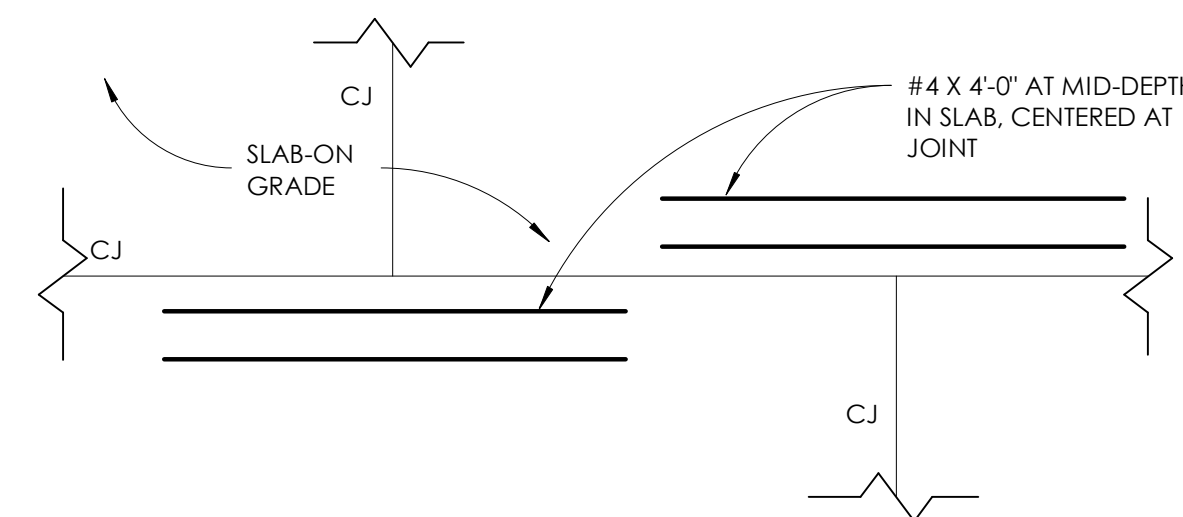

**5** REINFORCING AT SLAB JOINT  
1 1/2" = 1'-0"

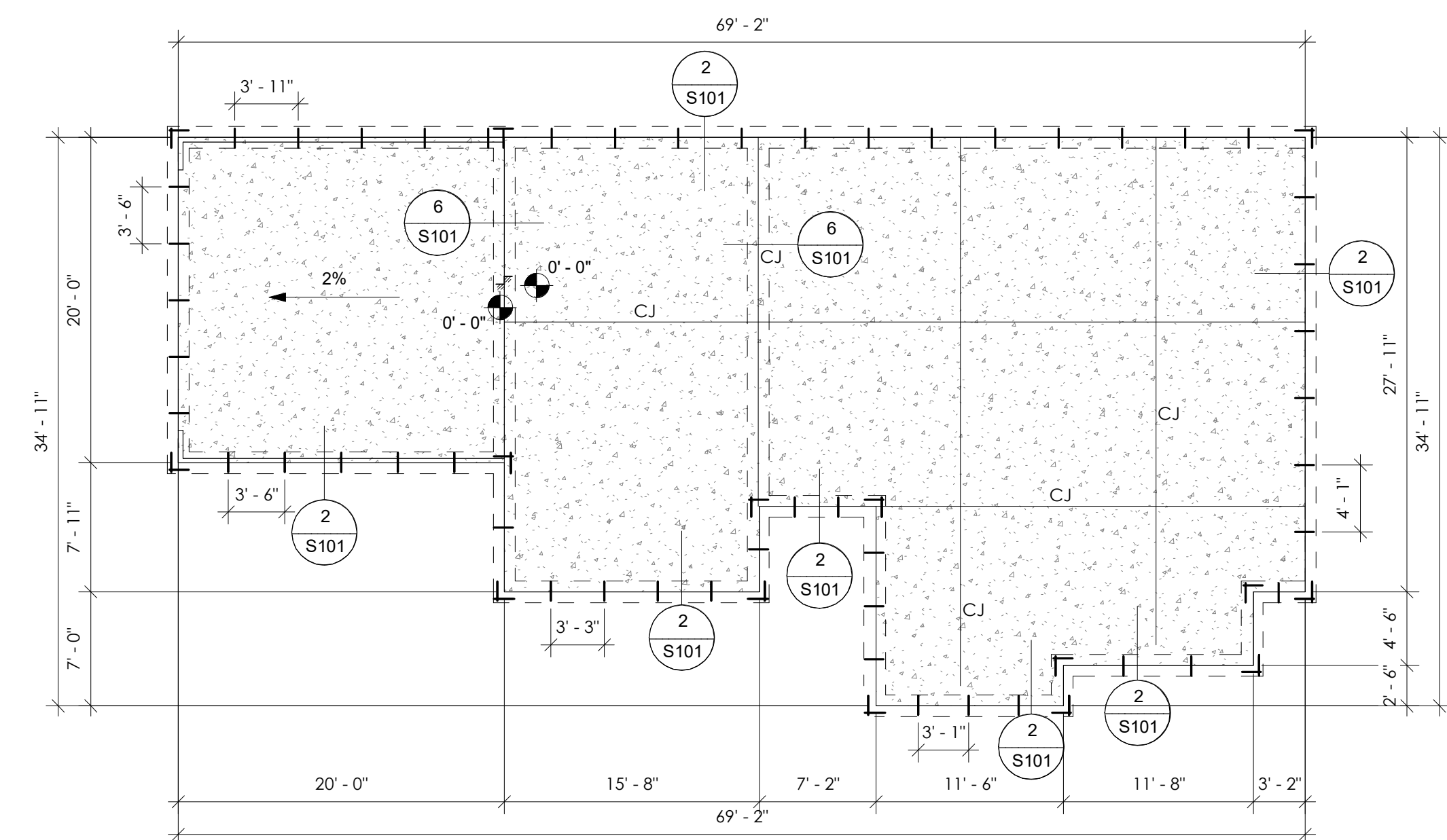

**1** STRUCTURAL FOUNDATIONS PLAN  
1/8" = 1'-0"

- FOUNDATION NOTES:**
- STRUCTURAL FOUNDATION SLAB TO BE POST TENSIONED. STRUCTURAL DESIGN OF POST TENSIONED SLAB TO BE DELEGATED TO WINNING CONTRACTOR AND MEET THE REQUIREMENTS OF THE POST TENSIONING INSTITUTE'S STANDARDS FOR SLAB-ON-GROUND, CURRENT EDITION, AS WELL AS DESIGN CRITERIA FROM THE AMERICAN CONCRETE INSTITUTE AND IBC 2018. ABOVE INFORMATION FOR REFERENCE ONLY

No.	Description	Date

REVISIONS

No.	Description	Date

Consultants

**SINGLE FAMILY HOME  
3 BR ADA HOME**

HOUSING AUTHORITY OF  
THE CHEROKEE NATION  
N. SHERIDAN RD. & E. 136TH ST. N.  
COLLINSVILLE, OK

Key Plan

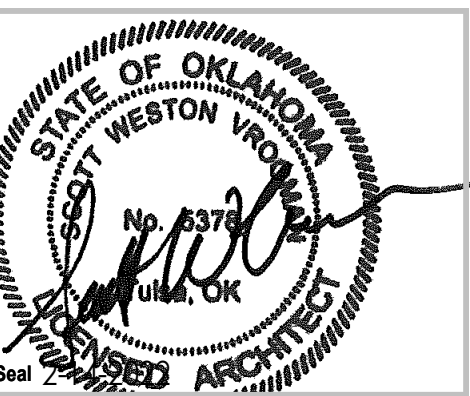

CONSTRUCTION DOCUMENTS

SHEET TITLE: **STRUCTURAL FOUNDATIONS PLAN/ DETAILS**  
DRAWN BY: Author  
CHECKED BY: Checker  
ISSUE DATE: 2-14-2022  
**S101**

PROJECT NO: 01-2207

BRICK LINTEL SCHEDULE			
TYPE	CLEAR SPANS (S)	ANGLE SIZE	BEARING (EACH END)
A	S ≤ 4'-0"	L4x4x3/8	8"
B	4'-0" < S ≤ 7'-0"	L6x4x3/8 (LLV)	8"
C	7'-0" < S ≤ 10'-0"	L8x4x1/2 (LLV)	16"

**5** BRICK LINTEL SCHEDULE  
3/4" = 1'-0"

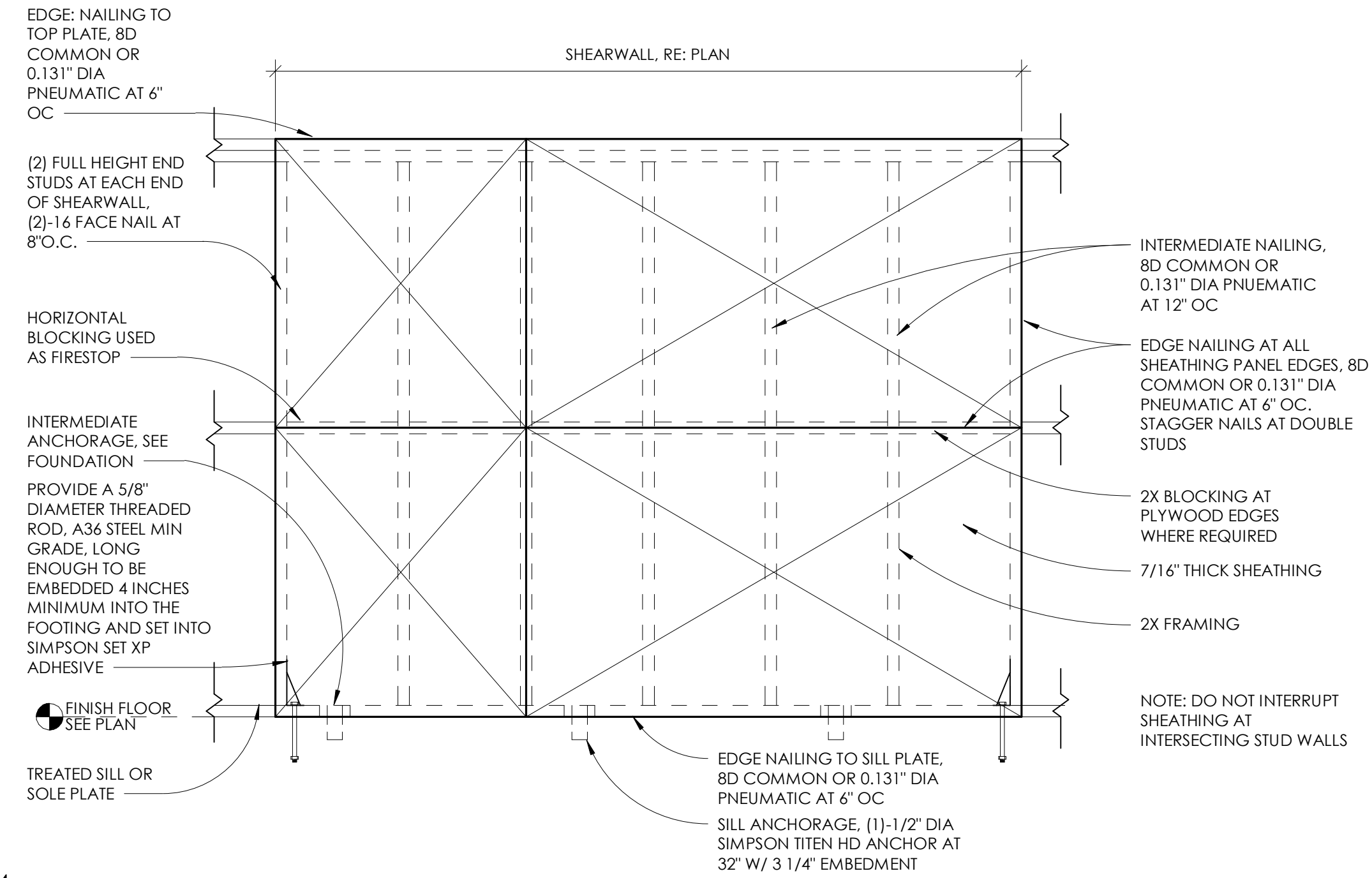

**4** SHEARWALL CONSTRUCTION AND SCHEDULE  
3/4" = 1'-0"

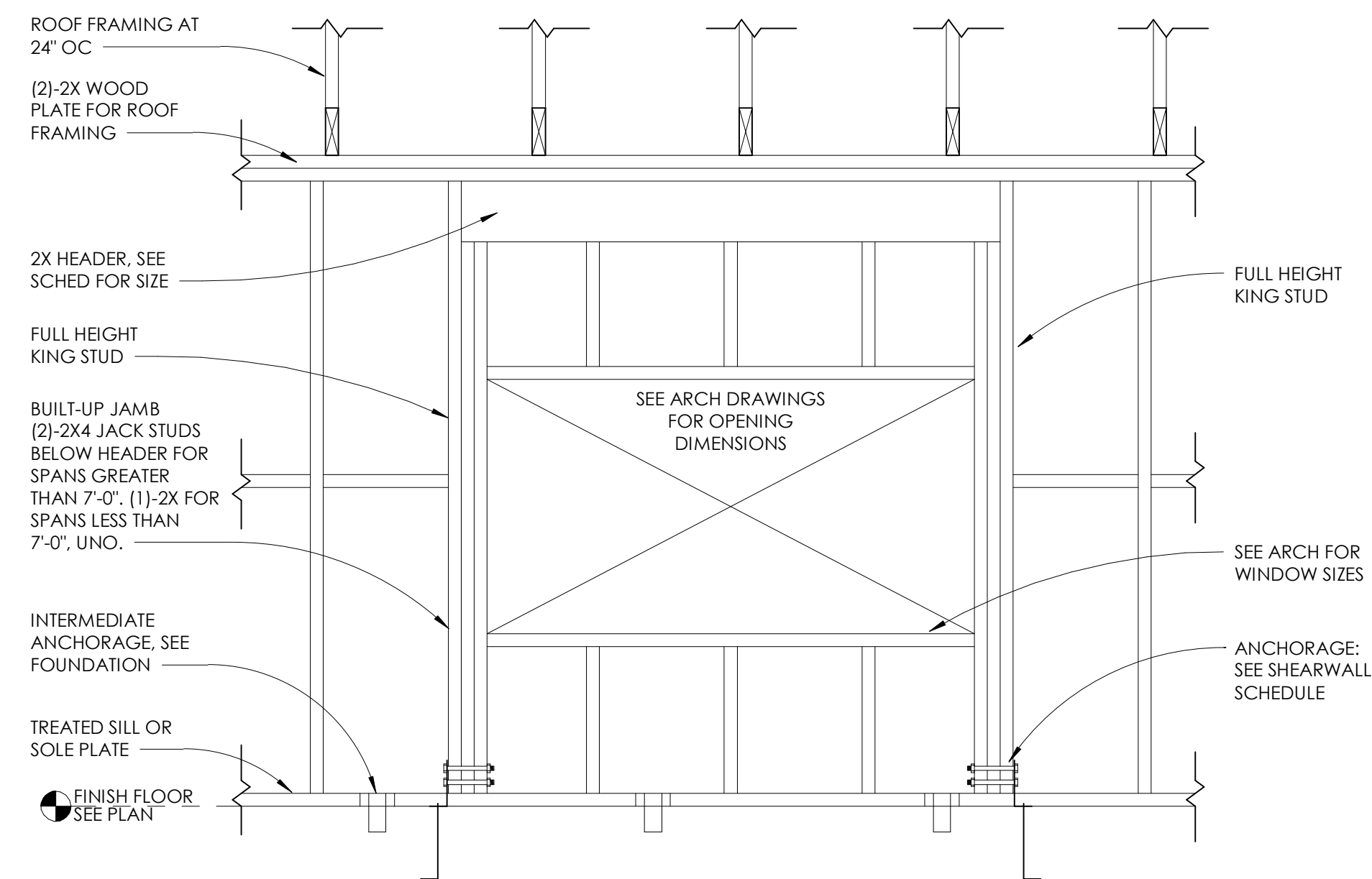

**2** EXTERIOR LINTEL ELEVATION AT BEARING WALL  
3/4" = 1'-0"

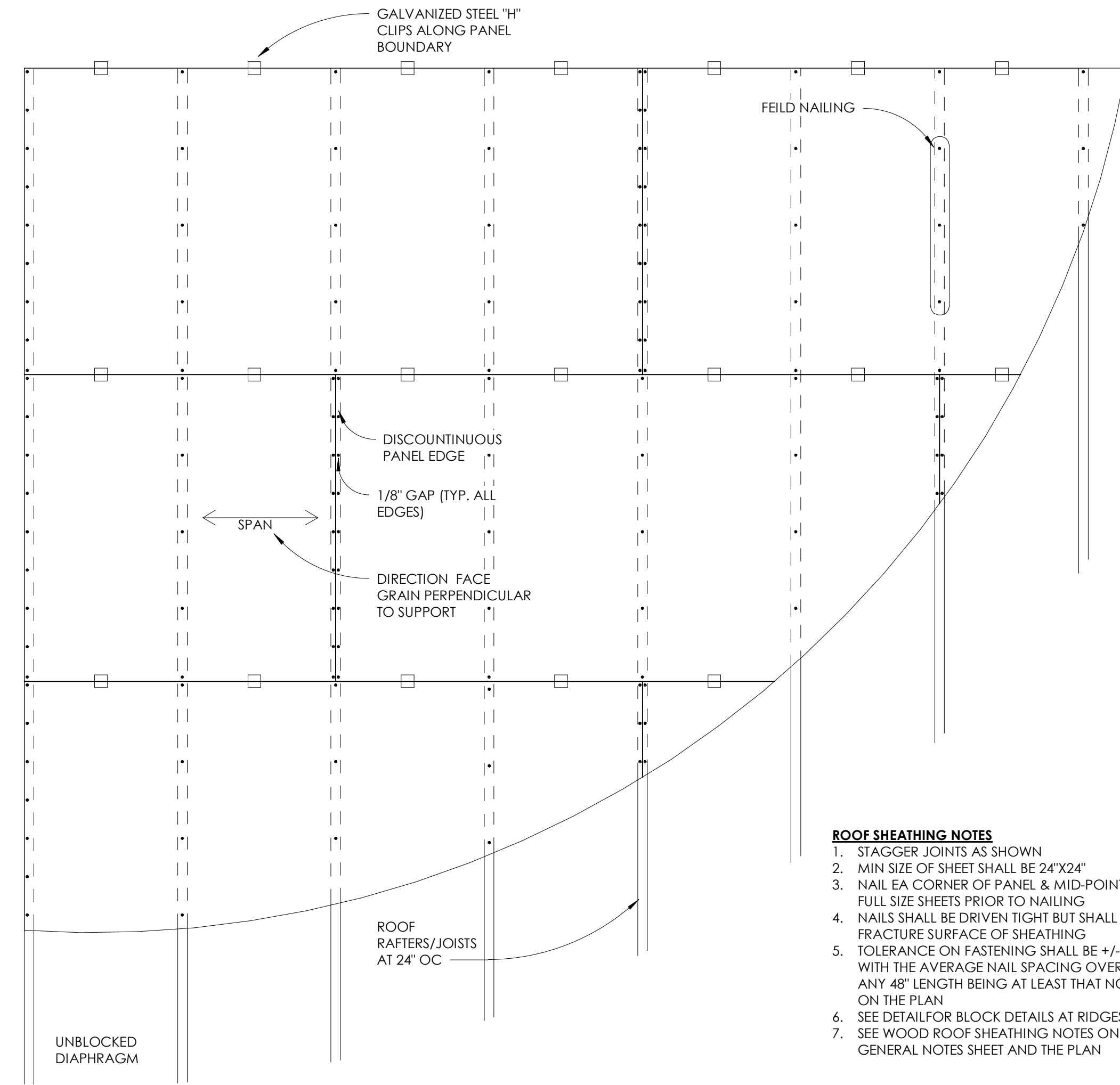

- ROOF SHEATHING NOTES**
1. STAGGER JOINTS AS SHOWN
  2. MIN SIZE OF SHEET SHALL BE 24"X24"
  3. NAIL EA CORNER OF PANEL & MID-POINT OF FULL SIZE SHEETS PRIOR TO NAILING
  4. NAILS SHALL BE DRIVEN TIGHT BUT SHALL NOT FRACTURE SURFACE OF SHEATHING
  5. TOLERANCE ON FASTENING SHALL BE +/- 1" WITH THE AVERAGE NAIL SPACING OVER ANY 48" LENGTH BEING AT LEAST THAT NOTED ON THE PLAN
  6. SEE DETAIL FOR BLOCK DETAILS AT RIDGES
  7. SEE WOOD ROOF SHEATHING NOTES ON THE GENERAL NOTES SHEET AND THE PLAN

**3** ROOF SHEATHING ON FRAMING  
3/4" = 1'-0"

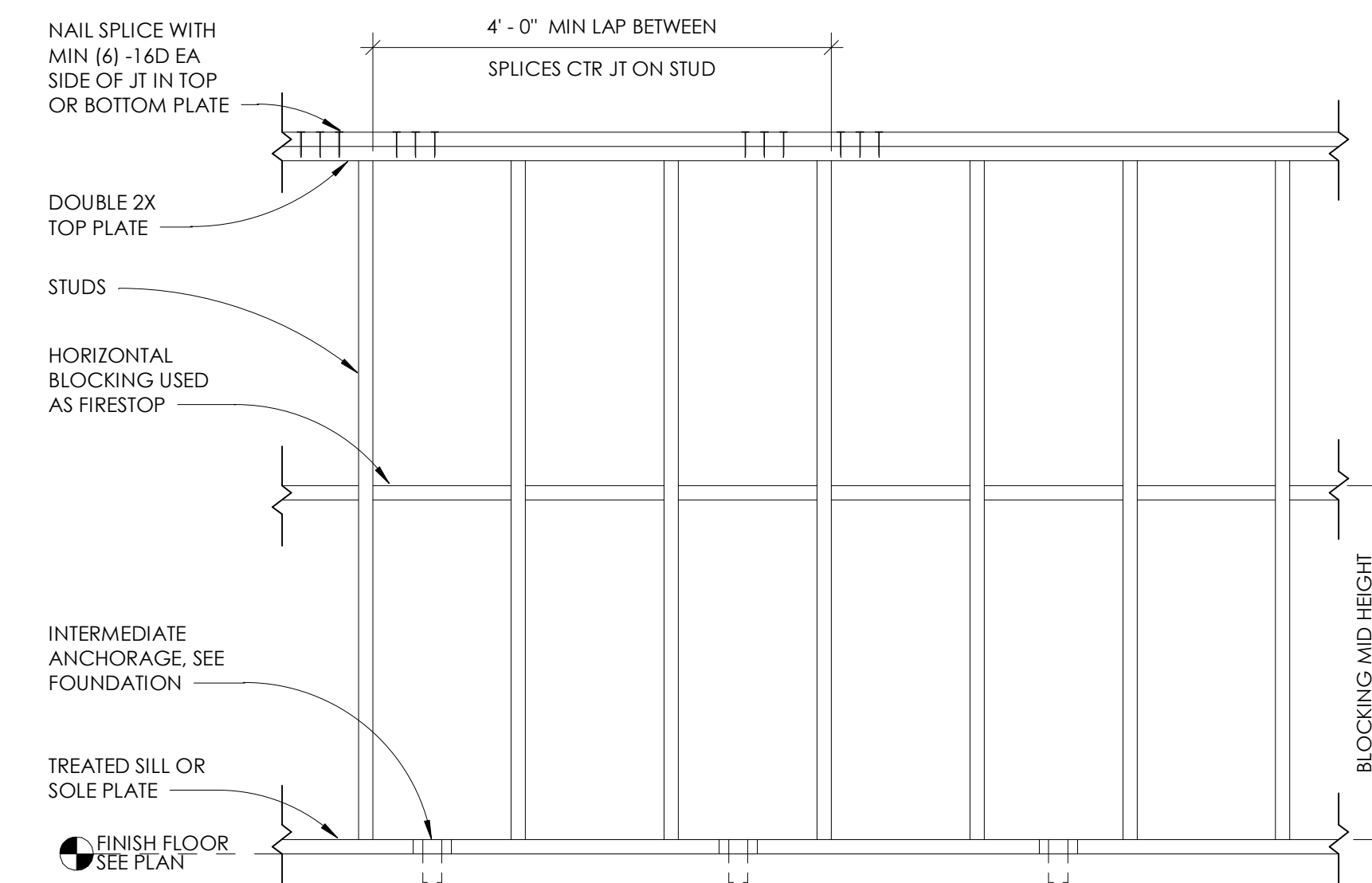

**1** TYP BEARING STUD WALL ELEVATION  
3/4" = 1'-0"



No.	Description	Date

REVISIONS

Consultants

**SINGLE FAMILY HOME  
3 BR ADA HOME**

HOUSING AUTHORITY OF  
THE CHEROKEE NATION  
N. SHERIDAN RD. & E. 136TH ST. N.  
COLLINSVILLE, OK

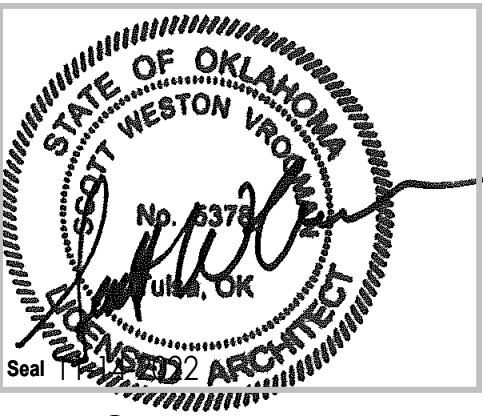

CONSTRUCTION DOCUMENTS

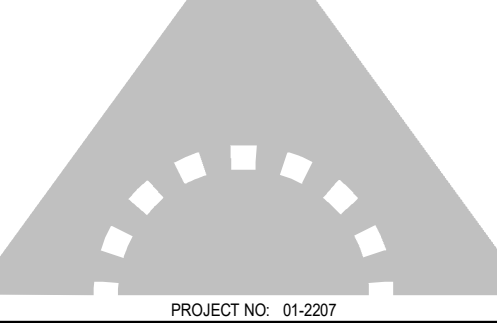

SHEET TITLE: FRAMING DETAILS

DRAWN BY: Author  
CHECKED BY: Checker  
ISSUE DATE: 2-14-2022

**S102**



SEE 2015 IRC TABLE R802.4.2 FOR SIZE AND SPACING OF CEILING JOISTS UNLESS SPECIFICALLY NOTED OTHERWISE

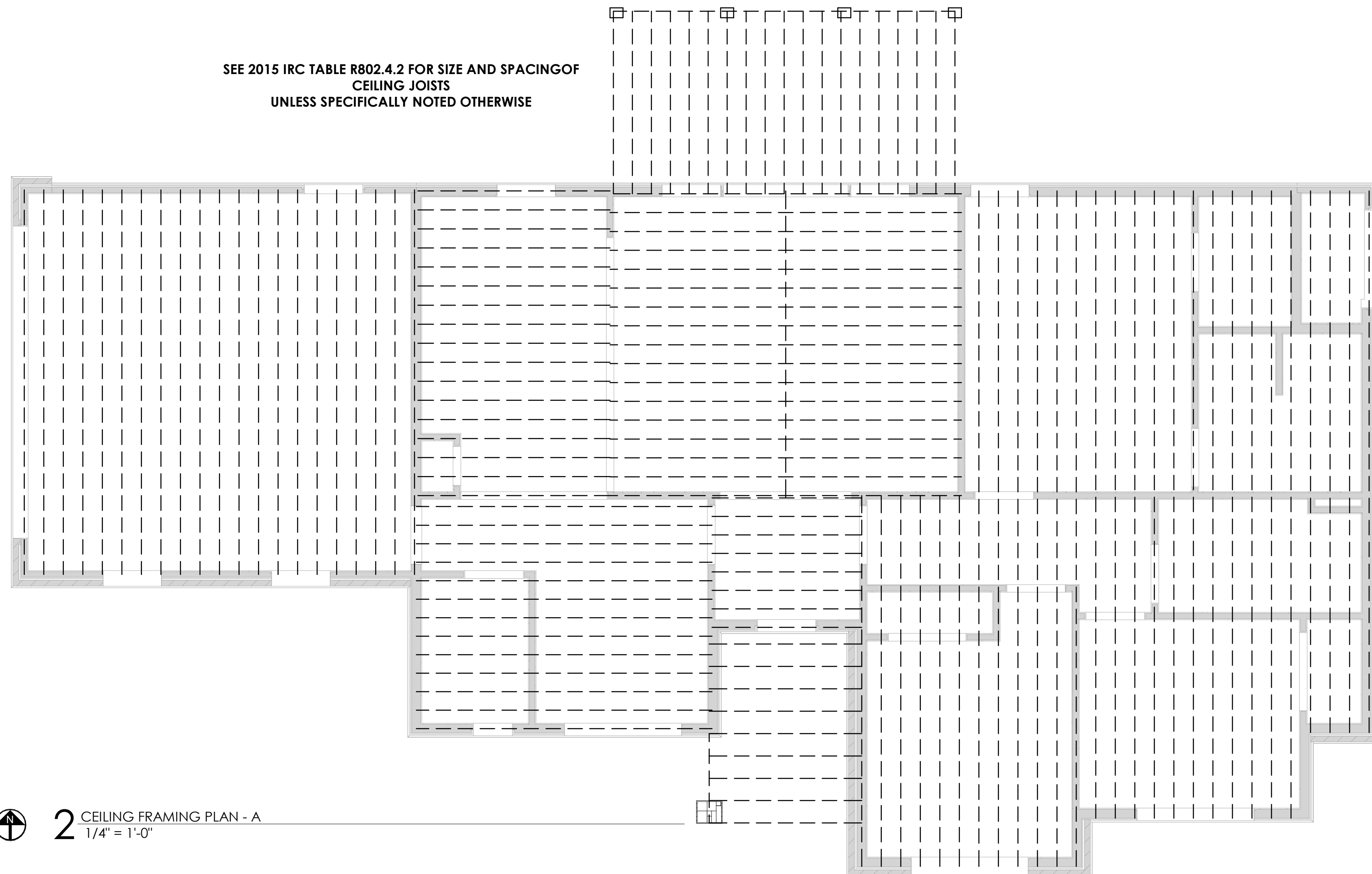

2 CEILING FRAMING PLAN - A  
1/4" = 1'-0"

(3)-PLY 1 3/4" X 9 1/4" DEEP HEADER

SEE 2015 IRC TABLE R802.5.1 FOR SIZE AND SPACING OF ROOF RAFTERS UNLESS SPECIFICALLY NOTED OTHERWISE

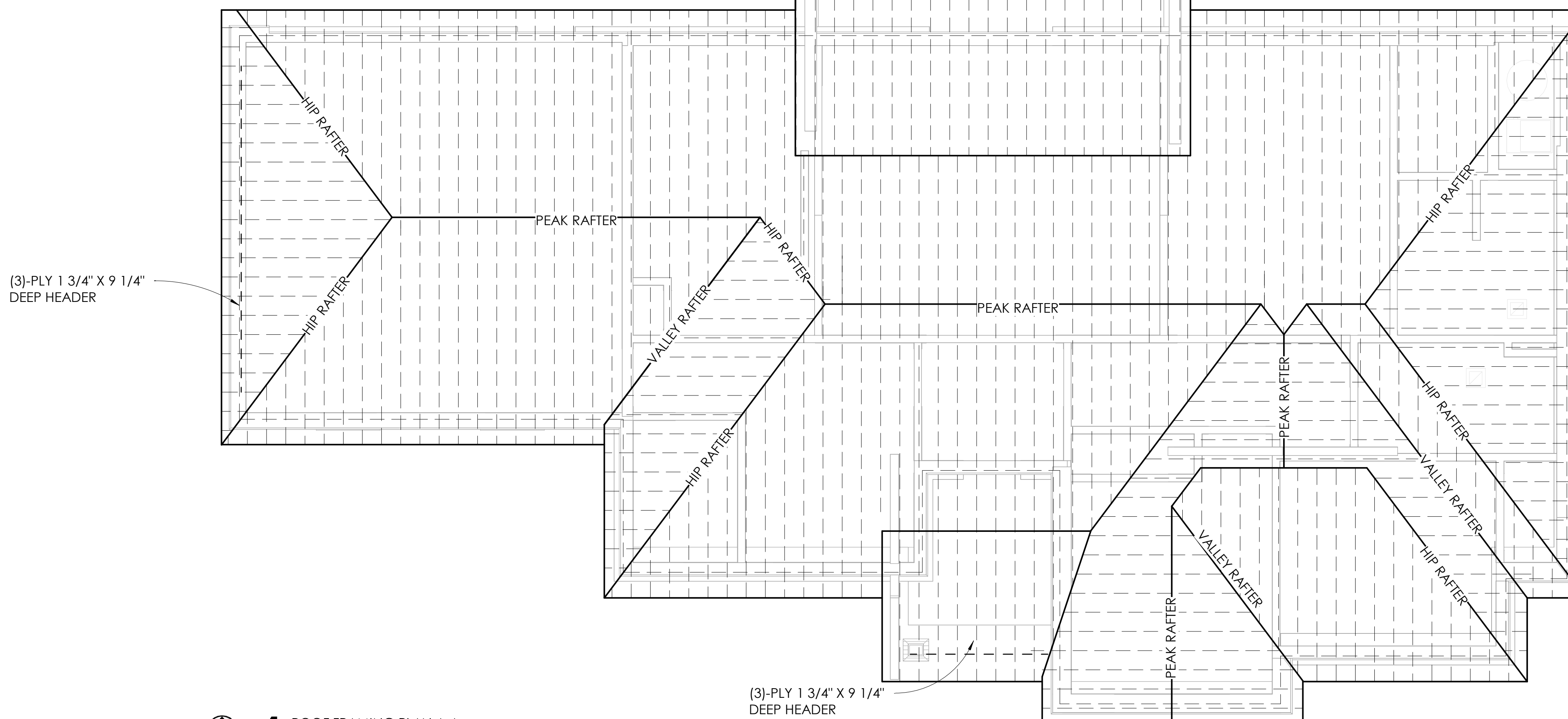

(3)-PLY 1 3/4" X 9 1/4" DEEP HEADER

(3)-PLY 1 3/4" X 9 1/4" DEEP HEADER

1 ROOF FRAMING PLAN A-A  
1/4" = 1'-0"



No.	Description	Date

REVISIONS

Consultants

**SINGLE FAMILY HOME  
3 BR ADA HOME**

HOUSING AUTHORITY OF  
THE CHEROKEE NATION

N. SHERIDAN RD. & E. 136TH ST. N.  
COLLINSVILLE, OK

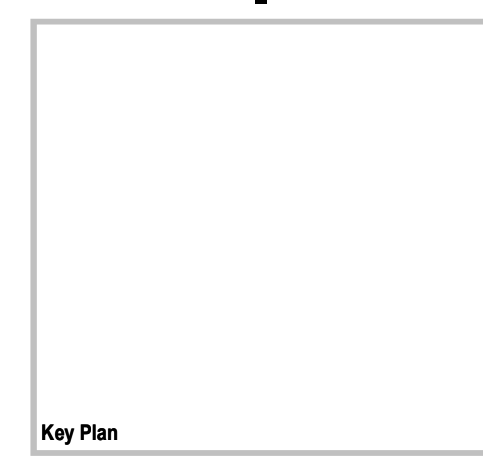

CONSTRUCTION DOCUMENTS

PROJECT NO. 01-2207

SHEET TITLE: ROOF AND CEILING FRAMING PLANS

DRAWN BY: Author  
CHECKED BY: Checker  
ISSUE DATE: 2-14-2022

**S103**

O N M L K J I H G F E D C B A

24-02022 12:03:30 PM  
 PRINT THIS SHEET FULL SIZE AT 24" X 36"  
 This document and the ideas and designs incorporated herein are an instrument of professional service in the property of TriArch and is not to be used, in whole or in part, for any other project, without the written authorization of TriArch.

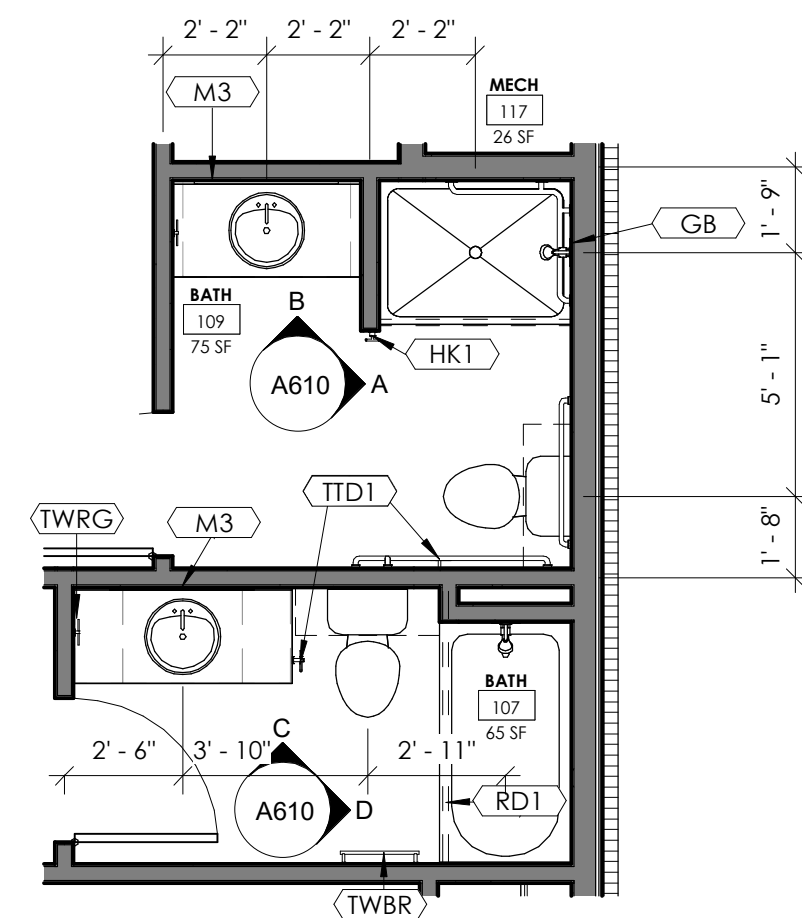

3 RESTROOM FLOOR PLAN  
1/4" = 1'-0"

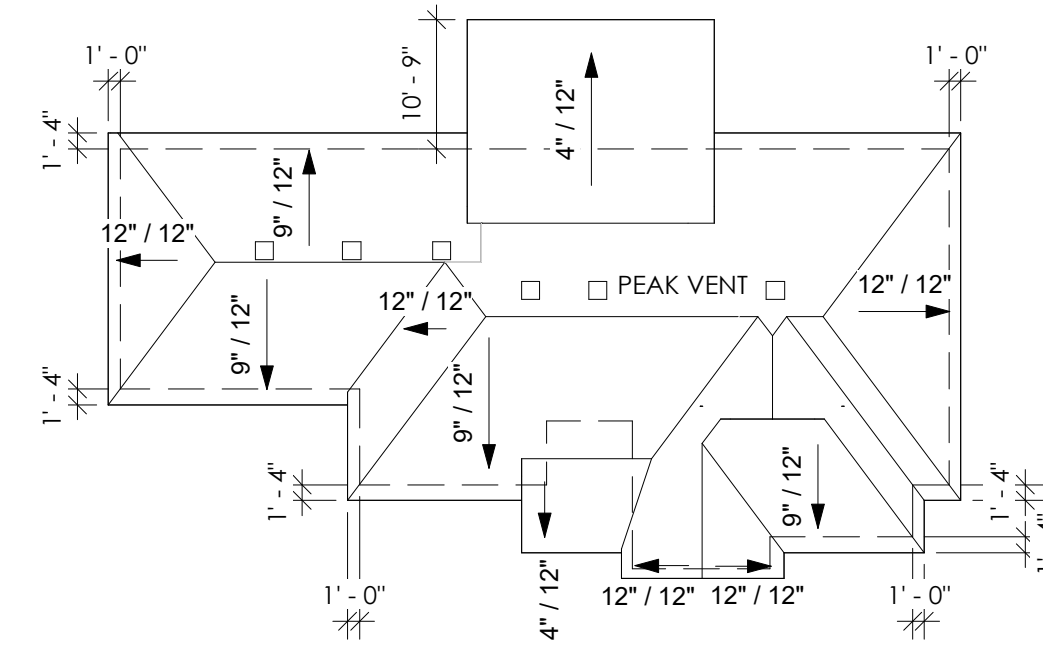

2 ROOF PLAN - A  
1/16" = 1'-0"

INTERIOR PARTITIONS	
<b>A. WALL CORE WIDTH</b>	<b>B. INSULATION TYPE</b>
4. 2x4 WOOD STUDS	A. ACOUSTICAL
6. 2x6 WOOD STUDS	T. THERMAL
	N. NONE
<b>C. WALL HEIGHT</b>	<b>I. CODE RATING</b>
L. LOW WALL - DOES NOT REACH CEILING. REF. ELEVATIONS FOR WALL HEIGHT	
1. WALL STUDS AND ONE SIDE GYP EXTEND TO PLATE	
2. WALL STUDS AND BOTH SIDES GYP EXTEND TO PLATE	
<b>GENERAL INTERIOR WALL CONSTRUCTION NOTES</b>	
1. AT PORTIONS OF WALL STRUCTURE (EX: STUDS) NOT OTHERWISE DEFINED WHICH ARE EXPOSED TO VIEW INSTALL 1/2" GYPSUM BD UltraLight FIRECODE PANELS AND PREPARE FOR PAINT.	
2. INSTALL MOLD & MOISTURE RESISTANT GYP BD NO LESS THAN 4' - 0" FROM ALL PLUMBING FIXTURES, UNLESS BEHIND TILE.	
3. INSTALL CEMENTITIOUS TILE BACKER BOARD BEHIND ALL TILE.	
4. INSTALL CONTROL JOINTS AS RECOMMENDED BY INDUSTRY STANDARDS, MAXIMUM 20'-0" ON CENTER, OR AS SHOWN OTHERWISE, WHICHEVER RESULTS IN SMALLER SPANS BETWEEN JOINTS. WHERE POSSIBLE, ALIGN VERTICAL JOINTS WITH DOOR OR WINDOW JAMBS OR OTHER OPENING EDGES.	
5. REF. WALL SECTIONS & DETAILS FOR EXTERIOR WALL CONSTRUCTION	

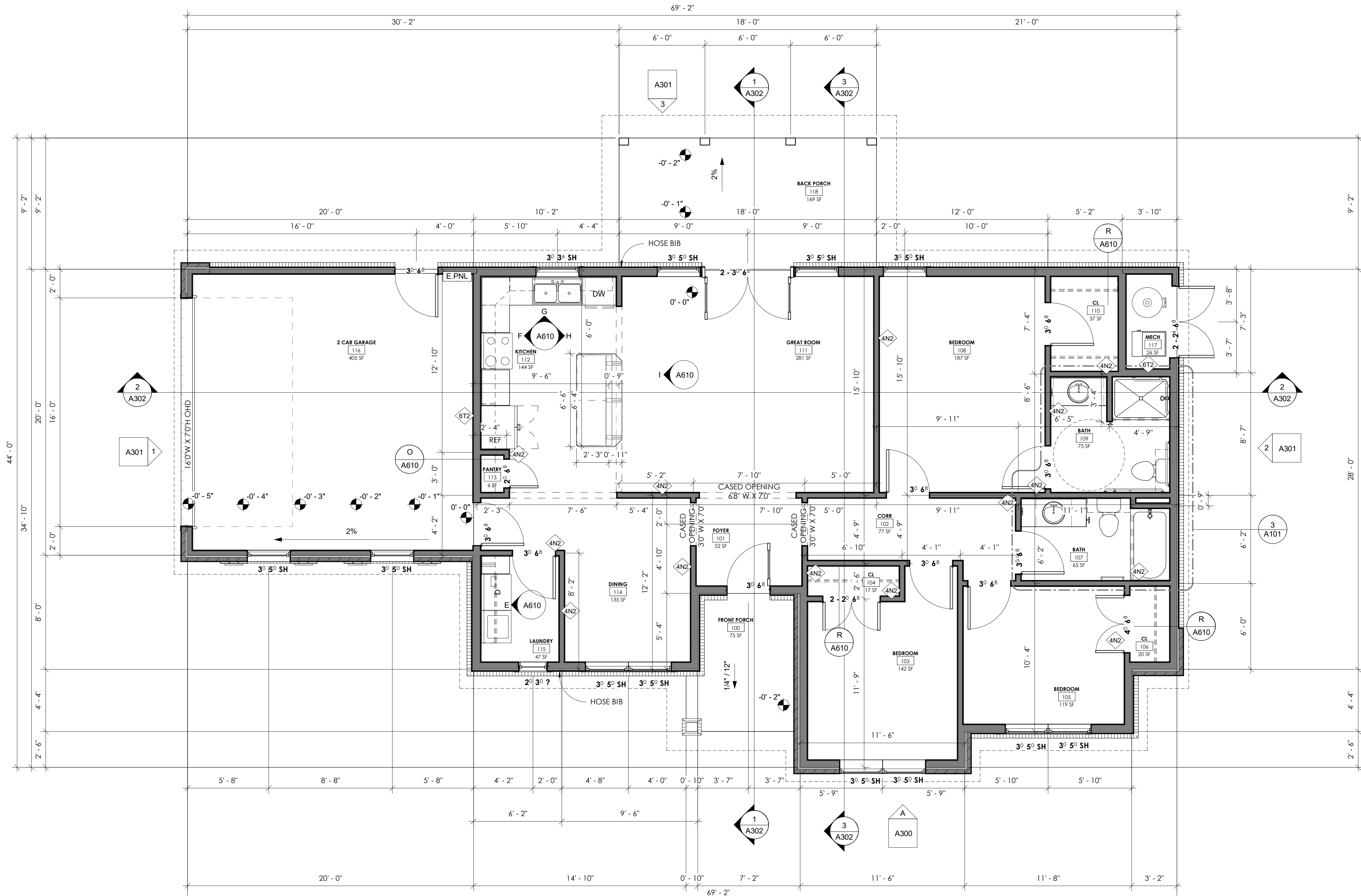

1 FLOOR PLAN - A (ALL DIMENSIONS ROUNDED TO THE NEAREST WHOLE INCH)  
1/4" = 1'-0"

ROOM SCHEDULE - RESIDENCE A		
#	Name	Area
EXTERIOR (COVERED)		
118	BACK PORCH	169 SF
100	FRONT PORCH	75 SF
LIVING		
107	BATH	65 SF
109	BATH	75 SF
108	BEDROOM	187 SF
103	BEDROOM	142 SF
105	BEDROOM	119 SF
110	CL	37 SF
106	CL	20 SF
104	CL	17 SF
102	CORR	77 SF
114	DINING	135 SF
101	FOYER	52 SF
111	GREAT ROOM	281 SF
112	KITCHEN	144 SF
115	LAUNDRY	47 SF
113	PANTRY	6 SF
UNCONDITIONED		
116	2 CAR GARAGE	405 SF
117	MECH	26 SF

HOMETYPE/BED./BATH./CAR GARAGE LUVABLE/ENCLOSED + EXTERIOR  
SINGLE FAM / 3 BR. - 2 BATH - 2 CAR G 1,442/1867 SF + 239 EX



No.	Description	Date

REVISIONS

Consultants

**SINGLE FAMILY HOME**  
**3 BR ADA HOME**

HOUSING AUTHORITY OF  
THE CHEROKEE NATION

N. SHERIDAN RD. & E. 136TH ST. N.  
COLLINSVILLE, OK

Key Plan



**CONSTRUCTION DOCUMENTS**

PROJECT NO: 01-2207

SHEET TITLE: FLOOR PLAN & ROOF PLAN

DRAWN BY: Author  
CHECKED BY: Checker  
ISSUE DATE: 2-14-2022

**A101**

This document, and the ideas and designs incorporated herein, are an instrument of professional service to the property of TriArch and is not to be shared, reproduced, or used for any other project, without the written authorization of TriArch. PRINT THIS SHEET FULL SIZE AT 24" X 36"

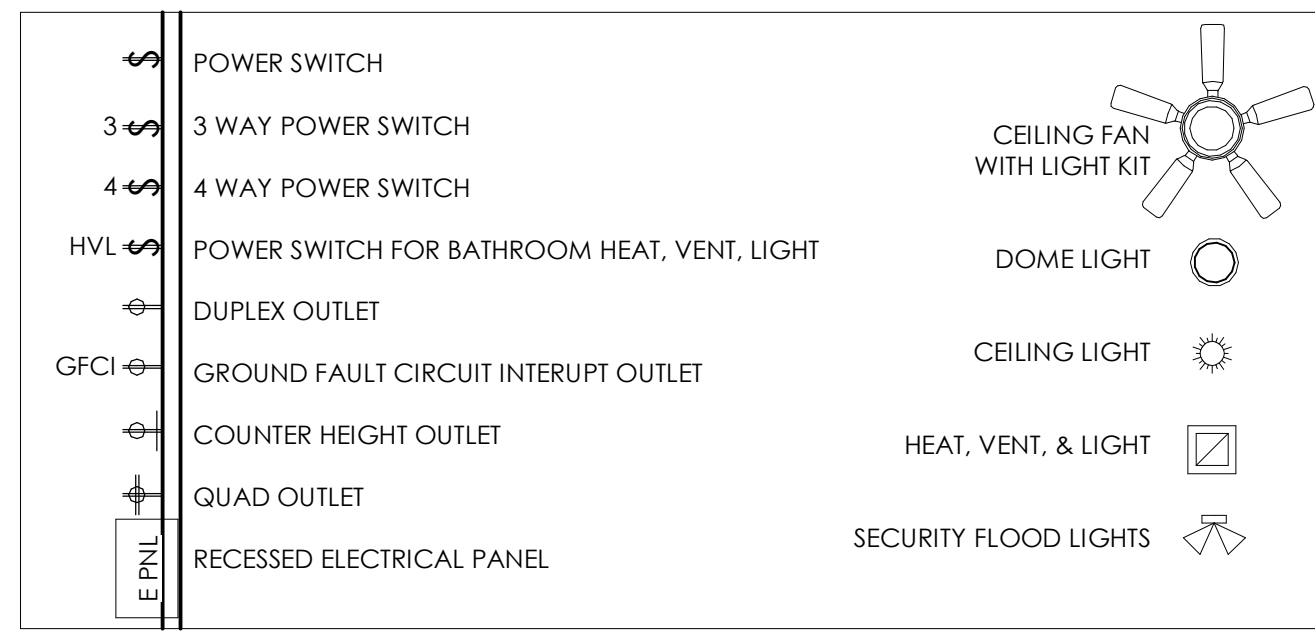

**REFER TO ELECTRICAL DRAWINGS FOR POWER LIGHTING AND SWITCHING LAYOUT**

**GENERAL ELECTRICAL NOTES:**

- 200 AMP SERVICE TO HOUSE. ELECTRICIAN TO VERIFY LOAD PRIOR TO INSTALLATION
- INSTALL CEILING FANS WITH LIGHT KITS IN ALL BEDROOMS, AND GREAT ROOM
- INSTALL GARAGE DOOR OPENER(S) IN GARAGE
- LOCATE ELECTRICAL OUTLETS 18" A.F.F. OR 8" ABOVE COUNTER
- USE GFCI OUTLETS WITHIN 4' - 0" OF ANY PLUMBING FIXTURE OR WET LOCATION, INCLUDING BATHROOMS, KITCHEN, GARAGE AND EXTERIOR
  - UNLESS NOTED OTHERWISE, INCLUDE ELECTRICAL OUTLETS AT THE FOLLOWING LOCATIONS:
    - 4 DUPLEX IN EACH BEDROOM
    - 4 DUPLEX & 1 QUAD IN GREAT ROOM
    - GFCI AT 4 O.C. IN KITCHEN
    - DUPLEX AT 12" - 0" O.C. IN HALLWAYS AND OTHER ROOMS
    - AT LEAST 1 CONVENIENCE DUPLEX IN EACH ROOM, EXCEPT CLOSETS UNDER 40 SF
  - 2 QUAD IN GARAGE
  - AS REQUIRED FOR EQUIPMENT (FURNACE, H2O HEATER, WASHER, DRYER, REFRIGERATOR, GARBAGE DISPOSAL OVEN, STOVE, HOOD, MICROWAVE, GARAGE DOOR OPENER, ETC.)

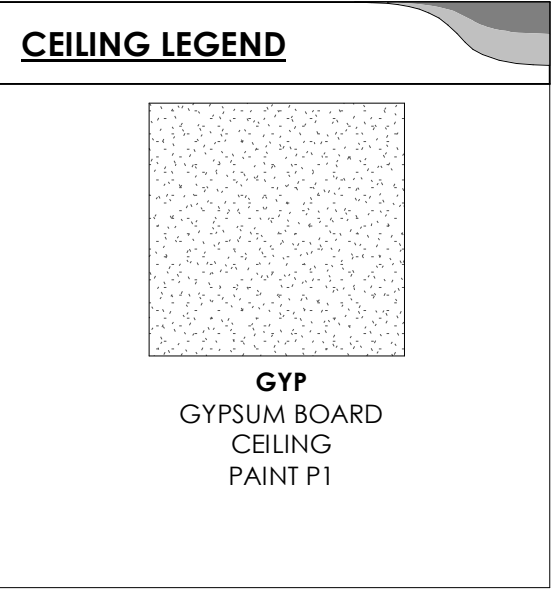

No.	Description	Date

REVISIONS

Consultants

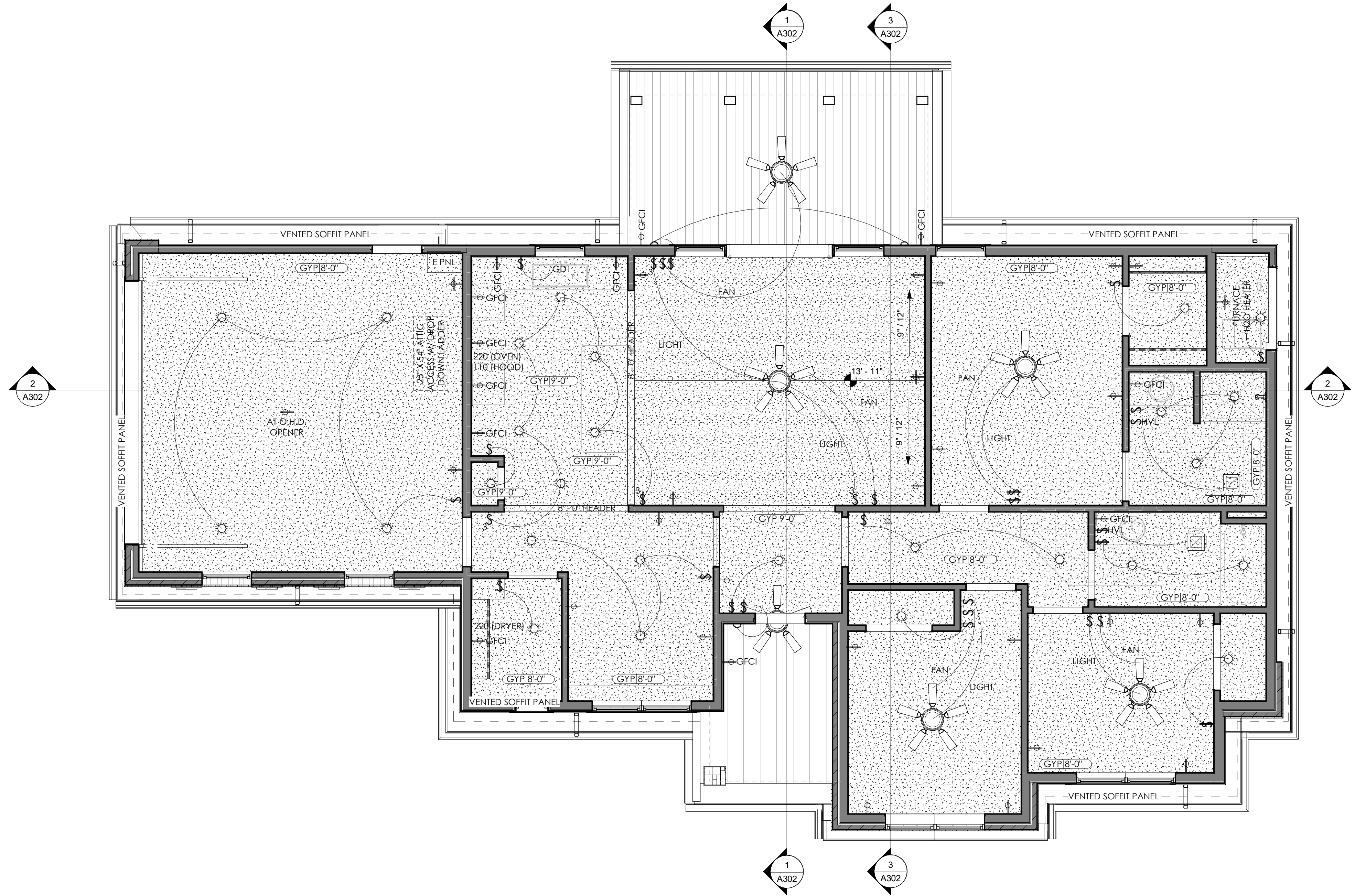

**1 PLAN A REFLECTED CEILING PLAN, AND ELECTRICAL LAYOUT**  
1/4" = 1'-0"

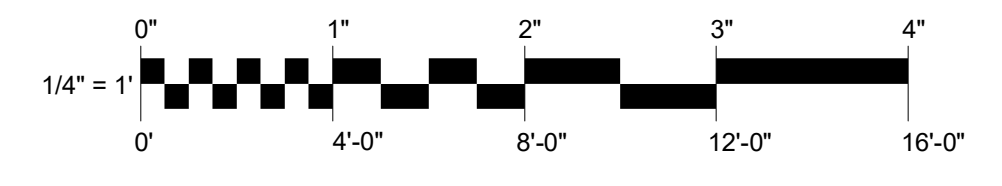

**SINGLE FAMILY HOME**  
**3 BR ADA HOME**

HOUSING AUTHORITY OF  
THE CHEROKEE NATION

N. SHERIDAN RD. & E. 136TH ST. N.  
COLLINSVILLE, OK

Key Plan

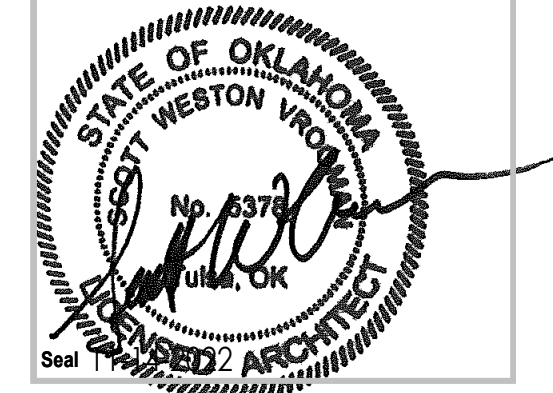

**CONSTRUCTION DOCUMENTS**

PROJECT NO: 01-2207

SHEET TITLE: REFLECTED CEILING PLAN

DRAWN BY: Author  
CHECKED BY: Checker  
ISSUE DATE: 2-14-2022

**A130**

PRINT THIS SHEET FULL SIZE AT 24" X 36" PROJECT NO: 01-2207

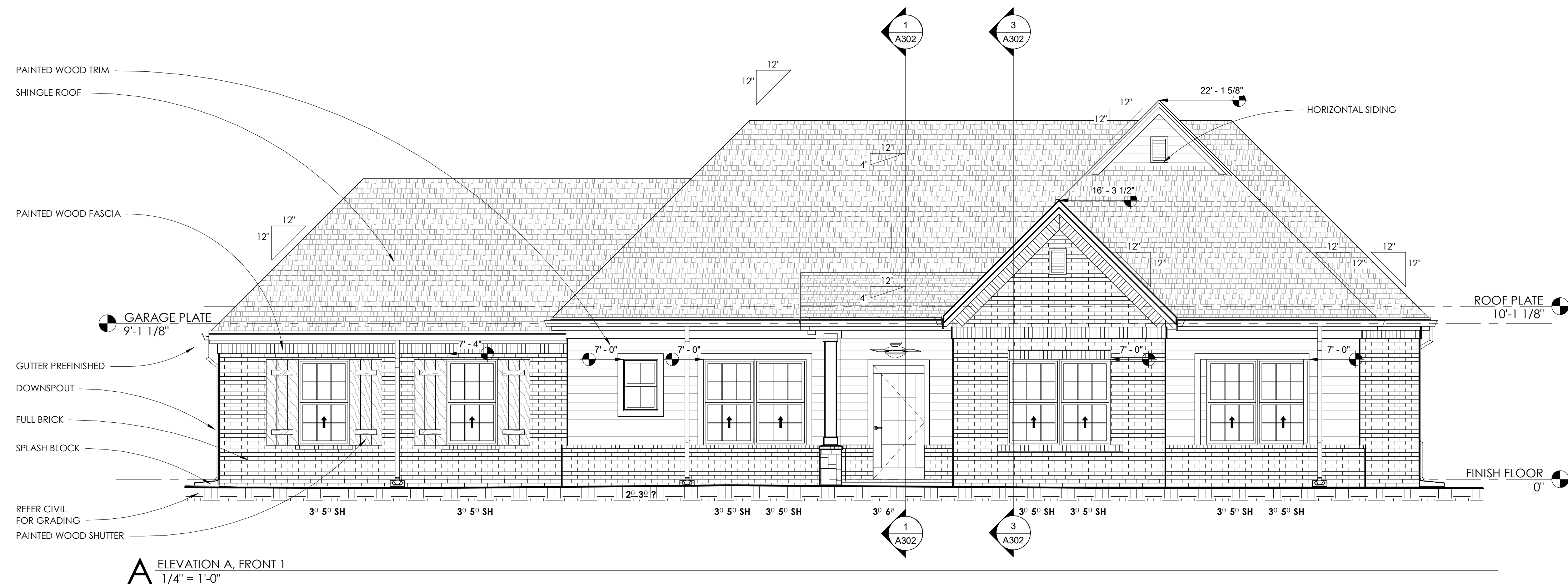

**A** ELEVATION A, FRONT 1  
1/4" = 1'-0"

**EXTERIOR COLORS**

ALL EXTERIOR COLORS TO BE REVIEWED AND VERIFIED BY OWNER, IN WRITING, WITH PHYSICAL SAMPLE MOCK UPS AT LEAST 2' - 0" X 2' - 0" IN SIZE EVALUATED OUTSIDE BOTH UNDER DIRECT SUNLIGHT AND UNDER SHADE. OWNER'S WRITTEN ACCEPTANCE OF SAMPLE IS REQUIRED PRIOR TO ORDERING EXTERIOR FINISH CONSTRUCTION MATERIALS.

**BRICK**  
ALL BRICK, TO BE 3 COLOR FAMILY BLEND

**STONE**  
FAUX STONE AT COLUMN BASES TO BE A SINGLE COLOR

**3 EXTERIOR PAINT COLORS:**

- FIELD COLOR AT SIDING, AND ROOF SOFFIT.  
A. SIDING & SOFFIT PANELING WITH INTEGRAL COLOR MATCHING  
FIELD PAINT COLOR IS ACCEPTABLE
- TRIM COLOR AT TRIM, ENTRY WOOD WORK AND ROOF FASCIA  
ACCENT COLOR AT FRONT DOOR AND SHUTTERS
- PRECISE COLORS TO BE DETERMINED BY CLIENT AND ARCHITECT DURING THE SUBMITTAL PROCESS

No.	Description	Date

REVISIONS

Consultants

**SINGLE FAMILY HOME  
3 BR ADA HOME**

HOUSING AUTHORITY OF  
THE CHEROKEE NATION

N. SHERIDAN RD. & E. 136TH ST. N.  
COLLINSVILLE, OK

Key Plan

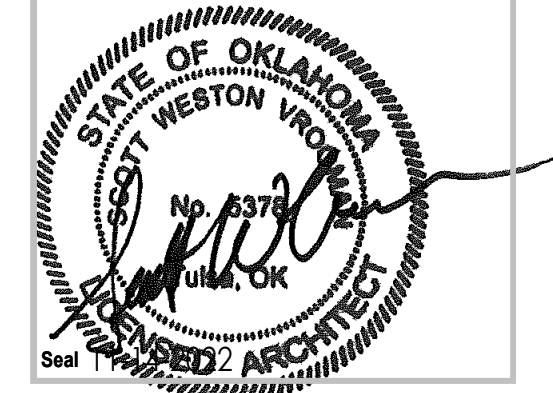

**CONSTRUCTION DOCUMENTS**

PROJECT NO. 01-2207

SHEET TITLE: **EXTERIOR ELEVATIONS - FRONT**

DRAWN BY: Author  
CHECKED BY: Checker  
ISSUE DATE: 2-14-2022

**A300**

21-02022-12-23-24 PM  
PRINT THIS SHEET FULL SIZE AT 24" X 36"  
This document, and the ideas and designs incorporated herein, are an instrument of professional service. In the event of a dispute, the user agrees to indemnify, defend, and hold the architect harmless for any other projects, without the written authorization of TriArch.

No.	Description	Date

REVISIONS

Consultants

# SINGLE FAMILY HOME 3 BR ADA HOME

HOUSING AUTHORITY OF  
THE CHEROKEE NATION  
N. SHERIDAN RD. & E. 136TH ST. N.  
COLLINSVILLE, OK

Key Plan



CONSTRUCTION DOCUMENTS

PROJECT NO. 01-2207

SHEET TITLE: EXTERIOR ELEVATIONS

DRAWN BY: Author  
CHECKED BY: Checker  
ISSUE DATE: 2-14-2022

# A301

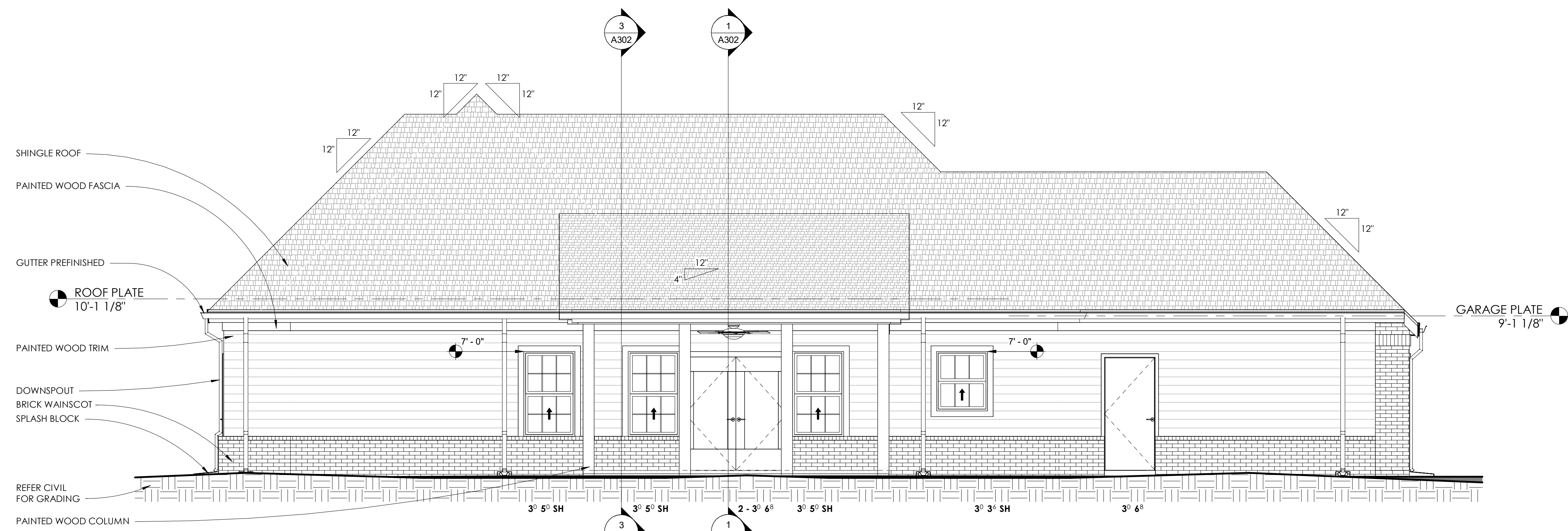

**3** ELEVATION A - BACK SIDE  
1/4" = 1'-0"

**EXTERIOR COLORS**

ALL EXTERIOR COLORS TO BE REVIEWED AND VERIFIED BY OWNER, IN WRITING, WITH PHYSICAL SAMPLE MOCK UPS AT LEAST 2' - 0" X 2' - 0" IN SIZE EVALUATED OUTSIDE BOTH UNDER DIRECT SUNLIGHT AND UNDER SHADE. OWNER'S WRITTEN ACCEPTANCE OF SAMPLE IS REQUIRED PRIOR TO ORDERING EXTERIOR FINISH CONSTRUCTION MATERIALS.

**BRICK**  
ALL BRICK, TO BE 3 COLOR FAMILY BLEND

**STONE**  
FAUX STONE AT COLUMN BASES TO BE A SINGLE COLOR

**3 EXTERIOR PAINT COLORS:**

1. FIELD COLOR AT SIDING, AND ROOF SOFFIT.
  - A. SIDING & SOFFIT PANELING WITH INTEGRAL COLOR MATCHING FIELD PAINT COLOR IS ACCEPTABLE
2. TRIM COLOR AT TRIM, ENTRY WOOD WORK AND ROOF FASCIA
3. ACCENT COLOR AT FRONT DOOR AND SHUTTERS

PRECISE COLORS TO BE DETERMINED BY CLIENT AND ARCHITECT DURING THE SUBMITTAL PROCESS

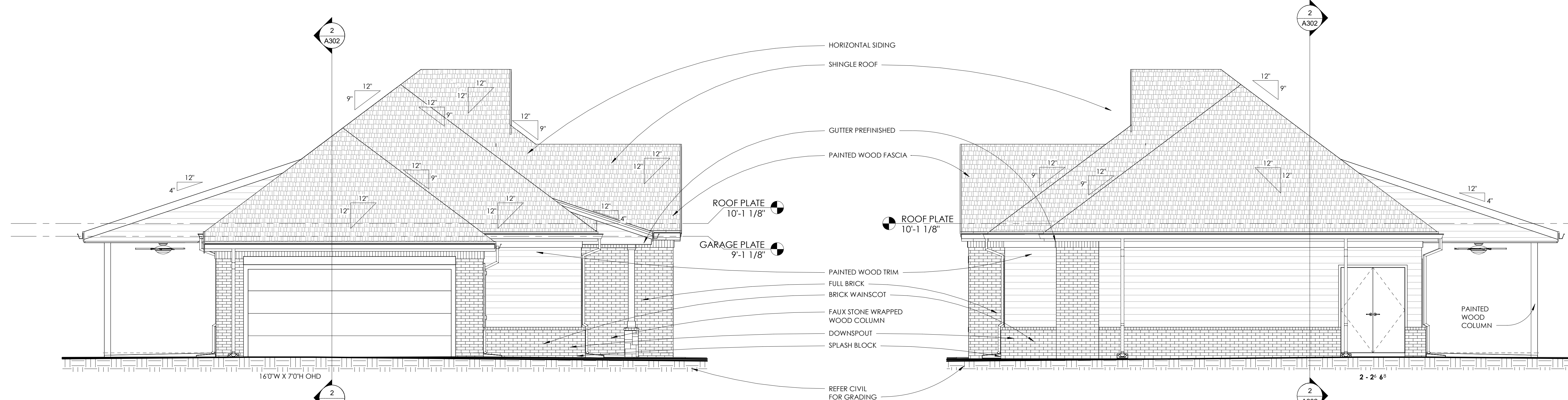

**1** ELEVATION A - LEFT SIDE  
1/4" = 1'-0"

**2** ELEVATION A - RIGHT SIDE  
1/4" = 1'-0"

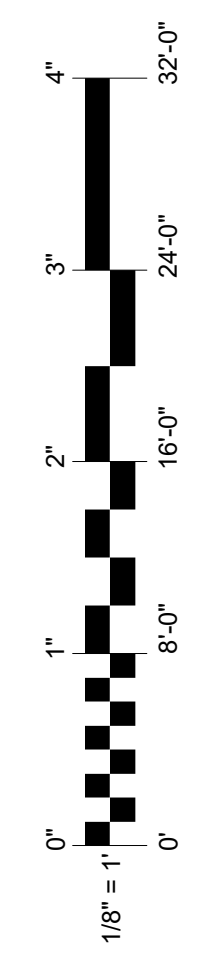

This document and the ideas and designs incorporated herein are an instrument of professional service, in the property of TriArch, and is not to be used, in whole or in part, for any other project, without the written authorization of TriArch.

21-02021 12:03:39 PM

No.	Description	Date
△		

REVISIONS

Consultants

**SINGLE FAMILY HOME  
3 BR ADA HOME**

HOUSING AUTHORITY OF  
THE CHEROKEE NATION

N. SHERIDAN RD. & E. 136TH ST. N.  
COLLINSVILLE, OK

Key Plan

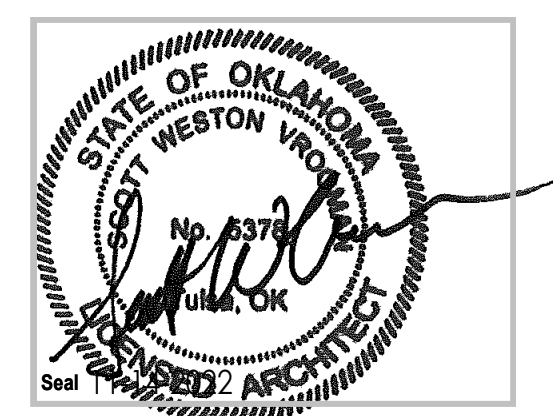

CONSTRUCTION DOCUMENTS

PROJECT NO. 01-2207

SHEET TITLE: BUILDING SECTIONS

DRAWN BY: Author  
CHECKED BY: Checker  
ISSUE DATE: 2-14-2022

**A302**

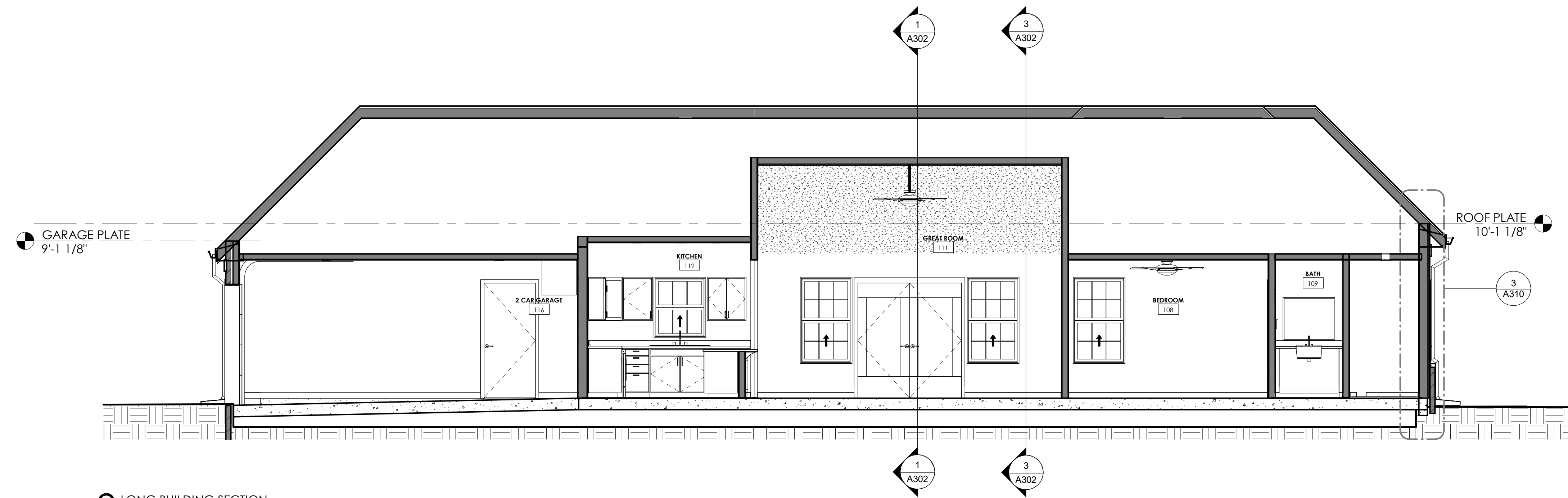

**2** LONG BUILDING SECTION  
1/4" = 1'-0"

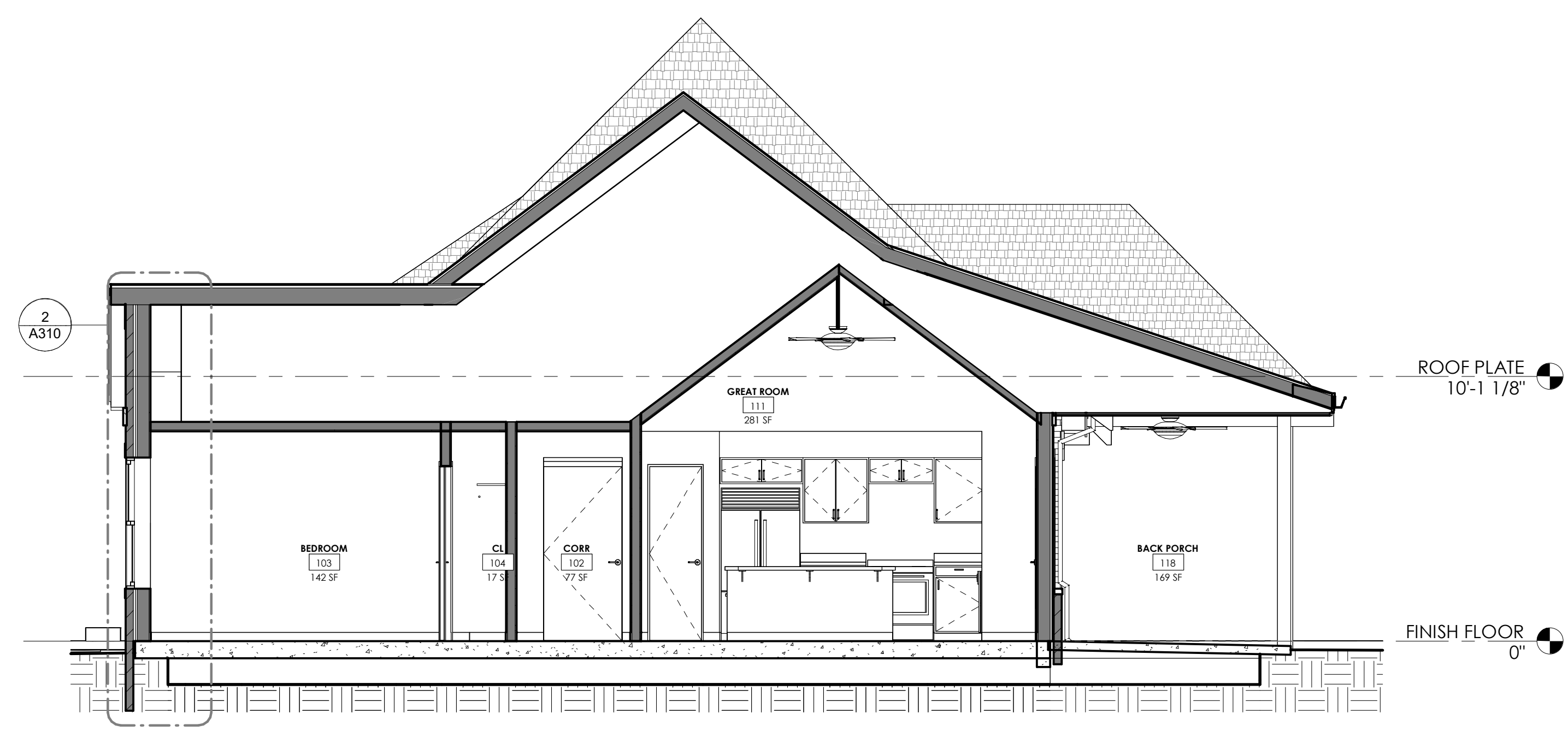

**3** SHORT BUILDING SECTION 2  
1/4" = 1'-0"

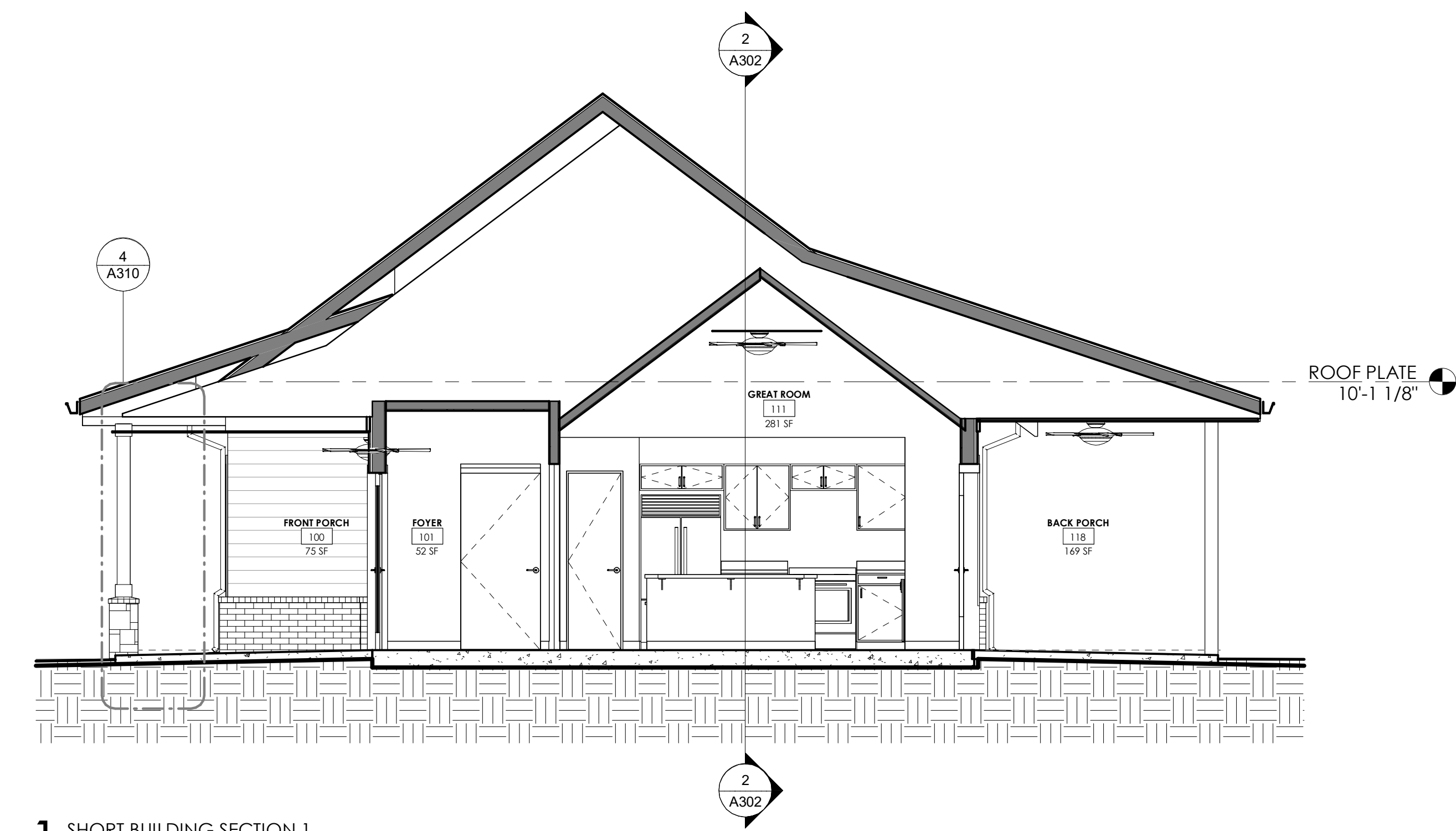

**1** SHORT BUILDING SECTION 1  
1/4" = 1'-0"

O | N | M | L | K | J | I | H | G | F | E | D | C | B | A

This document and the ideas and designs incorporated herein are an instrument of professional service, in the property of TriArch, and are not to be used, in whole or in part, for any other project, without the written authorization of TriArch.

24-02-2022 12:03:38 PM

PRINT THIS SHEET FULL SIZE AT 24" X 36"

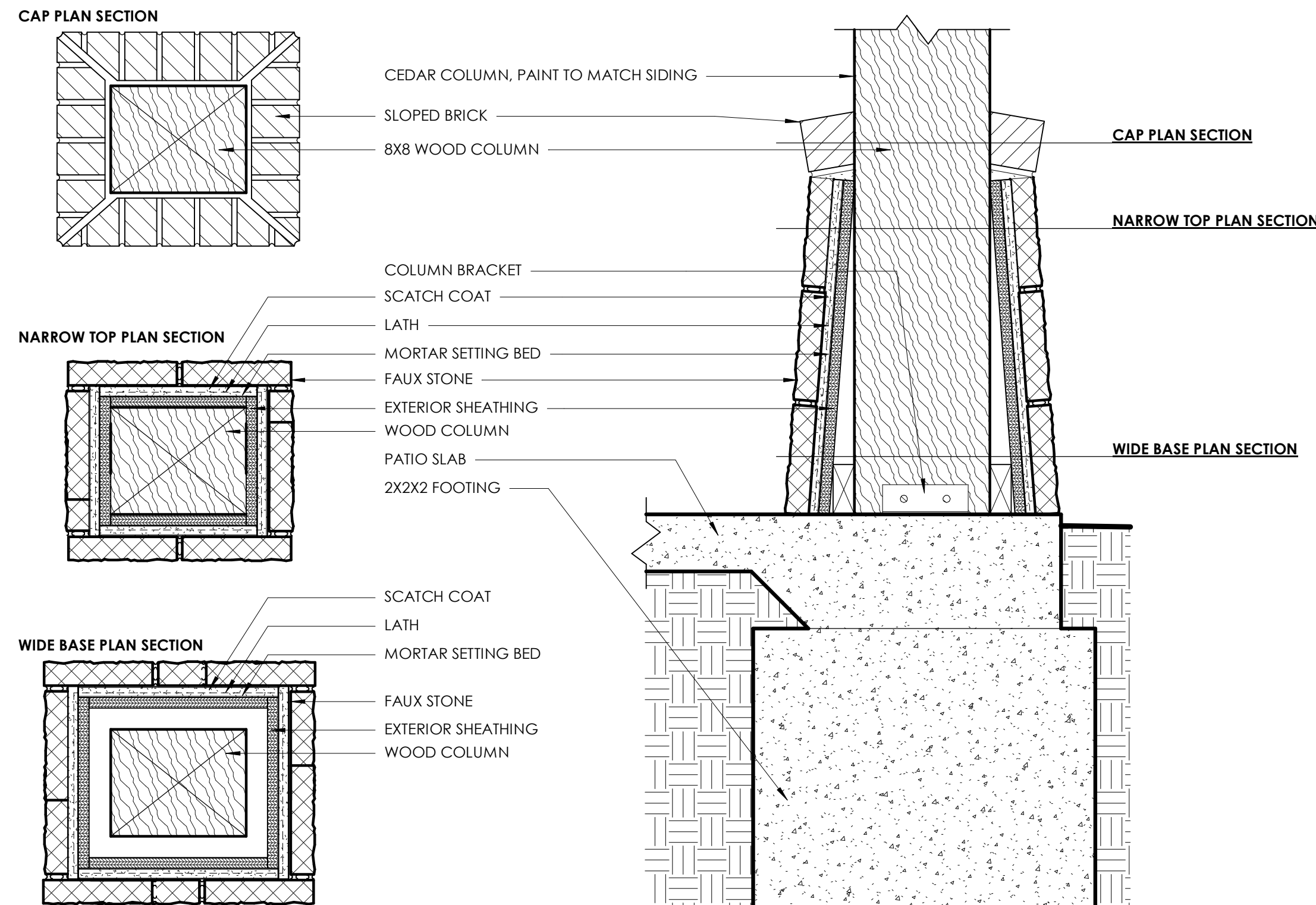

**4** FAUX STONE WRAPPED WOOD COLUMN DETAILS  
1 1/2" = 1'-0"

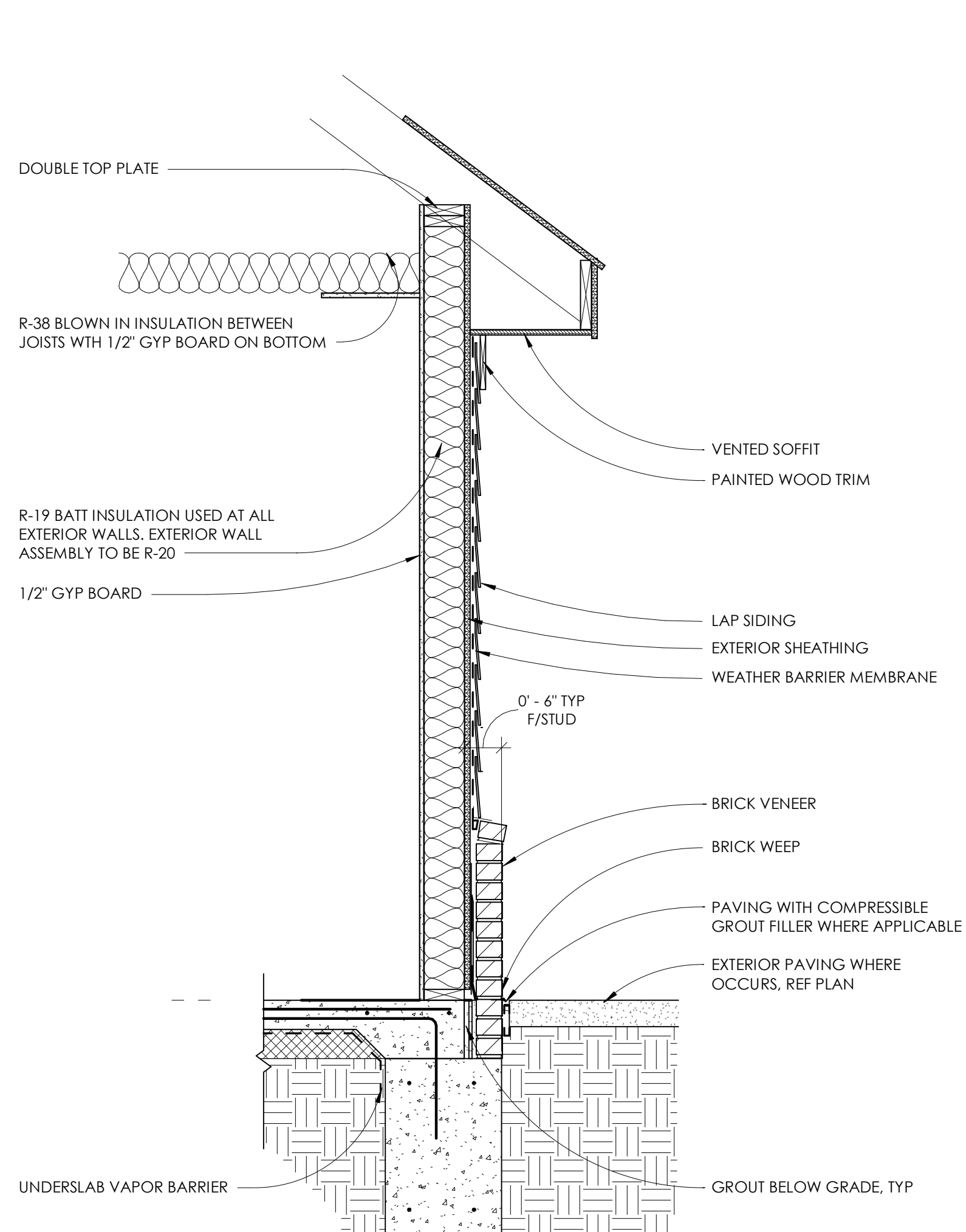

**3** BRICK WAJNSCOT BELOW SIDING  
3/4" = 1'-0"

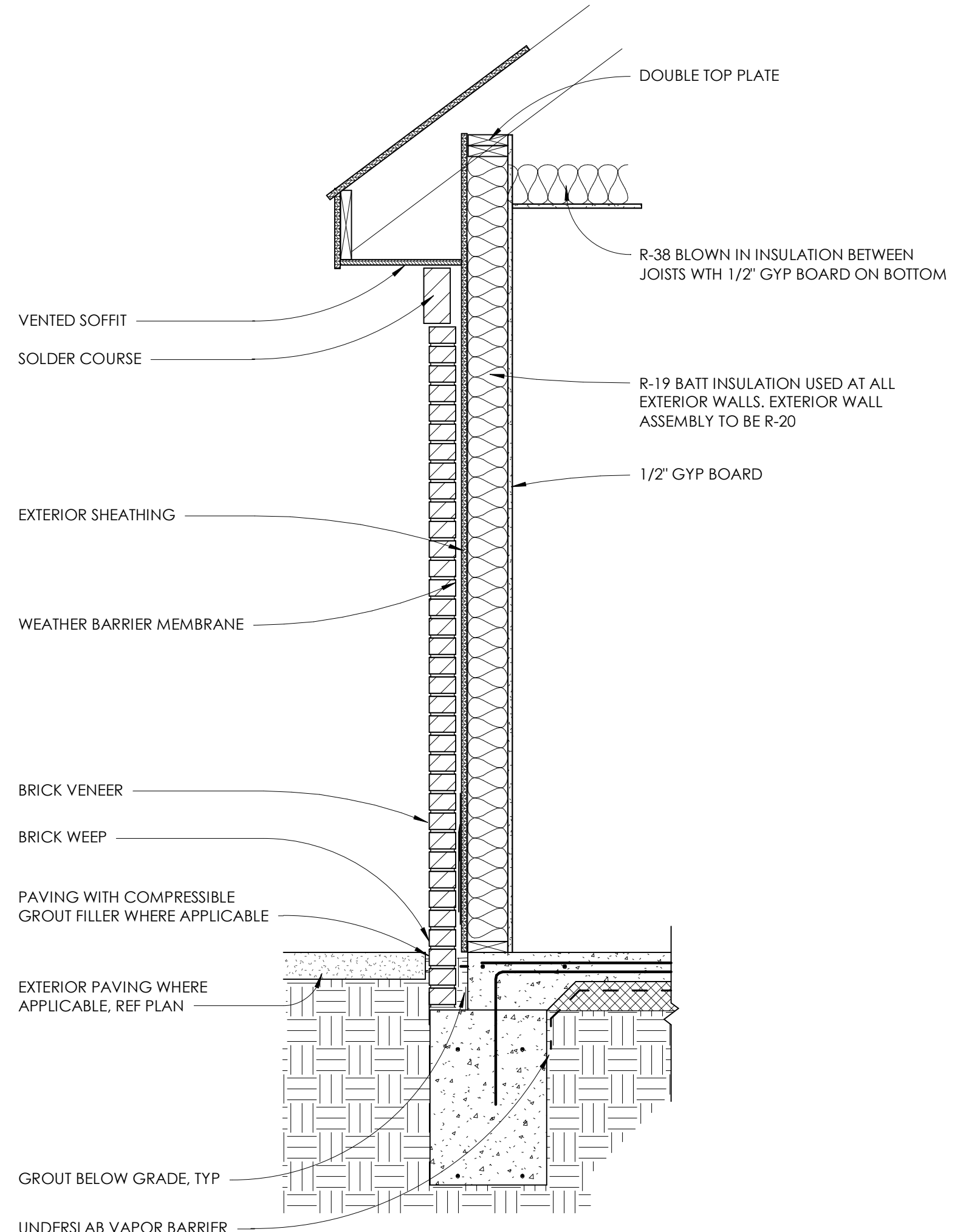

**2** FULL BRICK CLAD WALL  
3/4" = 1'-0"

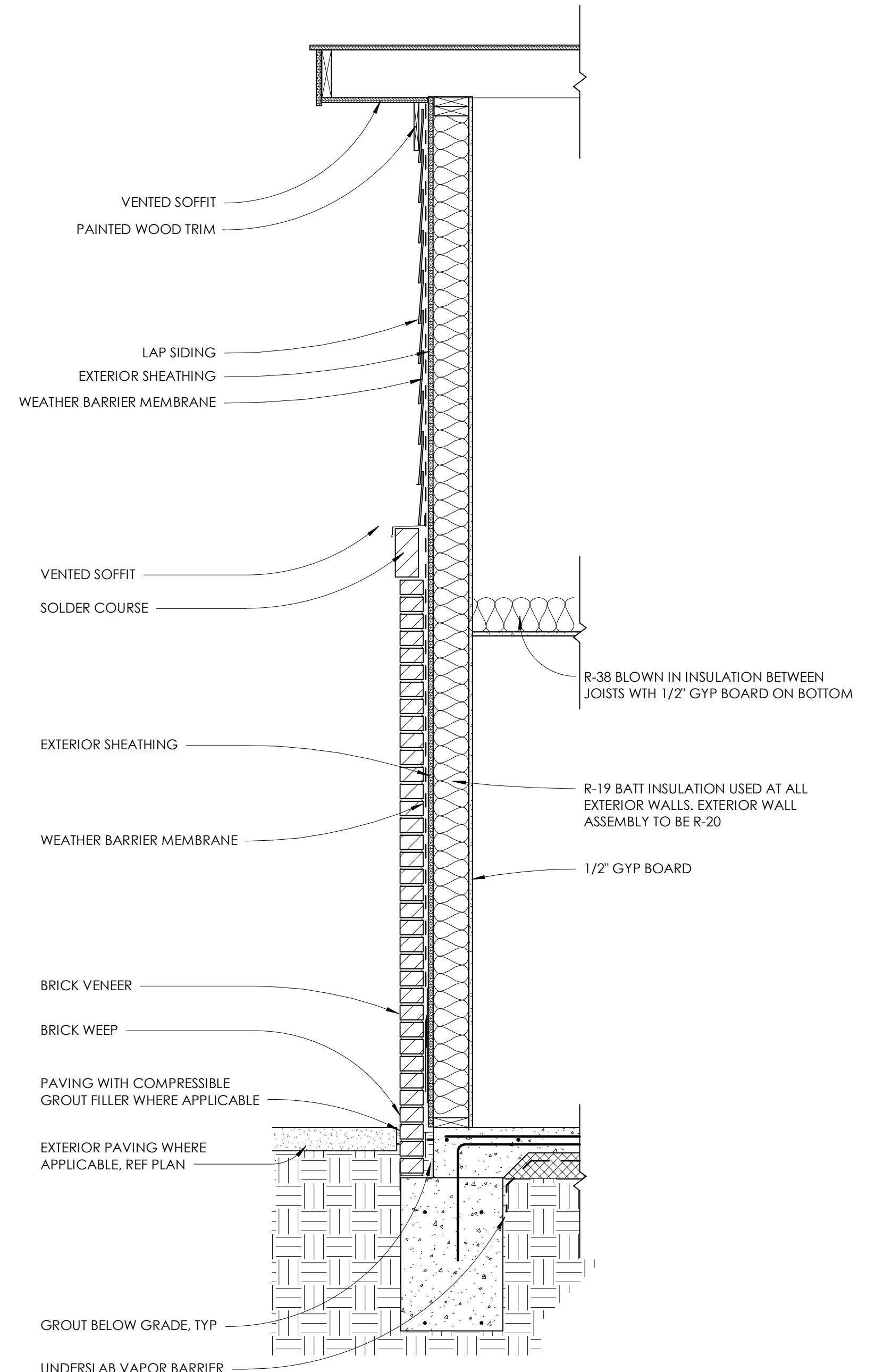

**1** FULL BRICK WITH SIDING ABOVE PLATE  
3/4" = 1'-0"

No.	Description	Date

REVISIONS

Consultants

**SINGLE FAMILY HOME  
3 BR ADA HOME**

HOUSING AUTHORITY OF  
THE CHEROKEE NATION

N. SHERIDAN RD. & E. 136TH ST. N.  
COLLINSVILLE, OK

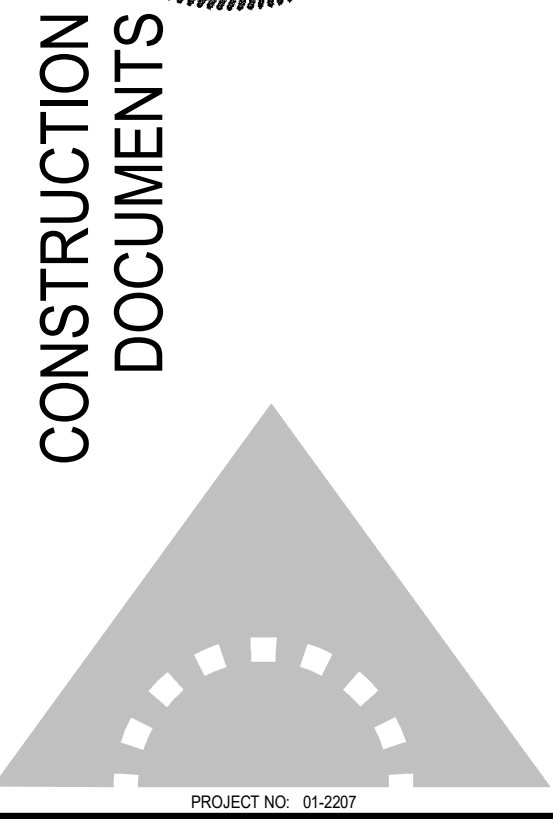
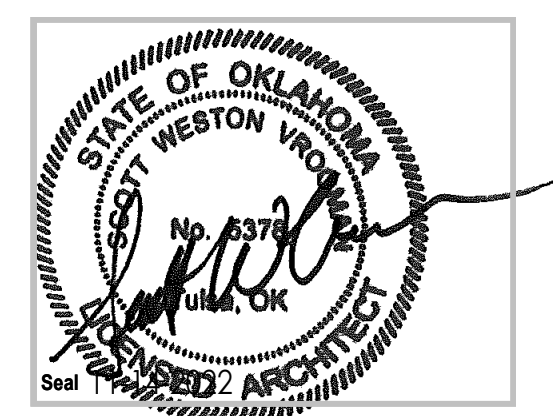
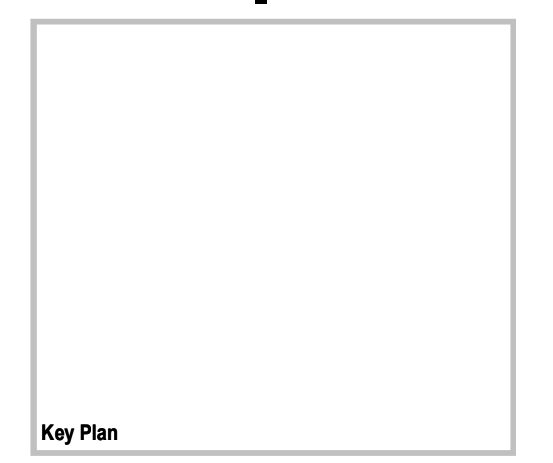

PROJECT NO: 01-2207

SHEET TITLE: **WALL SECTIONS**

DRAWN BY: Author  
CHECKED BY: Checker  
ISSUE DATE: 2-14-2022

**A310**

PRINT THIS SHEET FULL SIZE AT 24" X 36"

This document and the ideas and designs incorporated herein are an instrument of professional service. In the property of TriArch, and it is not to be used, reproduced, or otherwise disseminated in any form or by any means, without the written authorization of TriArch.

No.	Description	Date

REVISIONS

Consultants

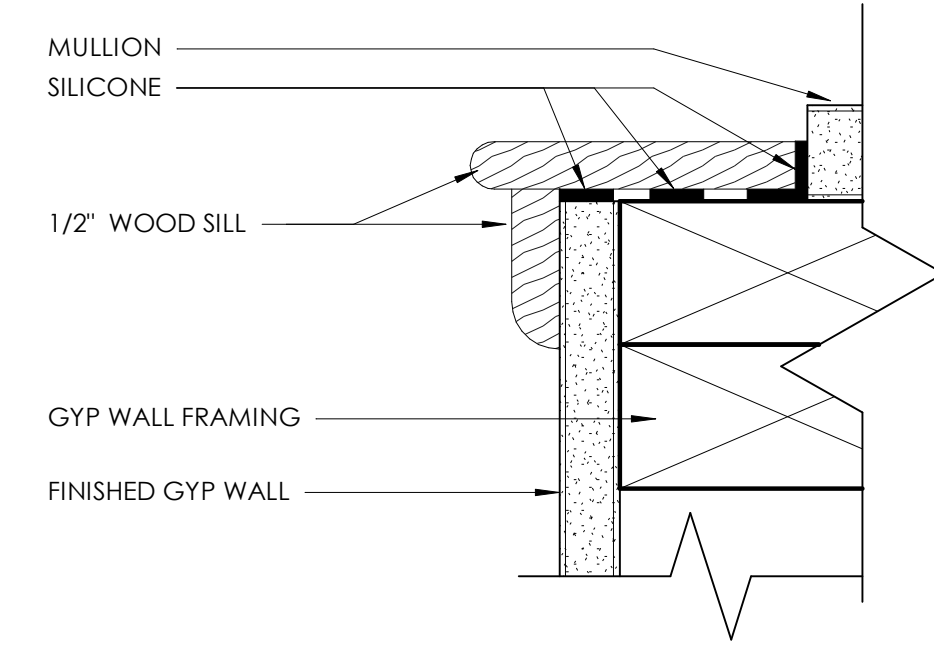

**D** TYPICAL INTERIOR WINDOW SILL  
6" = 1'-0"

**WINDOW SCHEDULE NOTES**

- REFER ELEVATIONS AND SPECIFICATIONS FOR GLAZING TYPES
- INSTALL TREATMENT FOR ALL TO REDUCE GLARE AND HEAT GAIN. REFERENCE SPECIALTIES SCHEDULE
- ALL FRAMES AND SILLS TO BE PAINTED **P2**

**GLAZING TYPES**

- USE 1" INSULATED CLEAR TEMPERED LOW EMISSIVITY GLAZING ON ALL EXTERIOR LITES, DOORS AND WINDOWS, UNLESS OTHERWISE NOTED

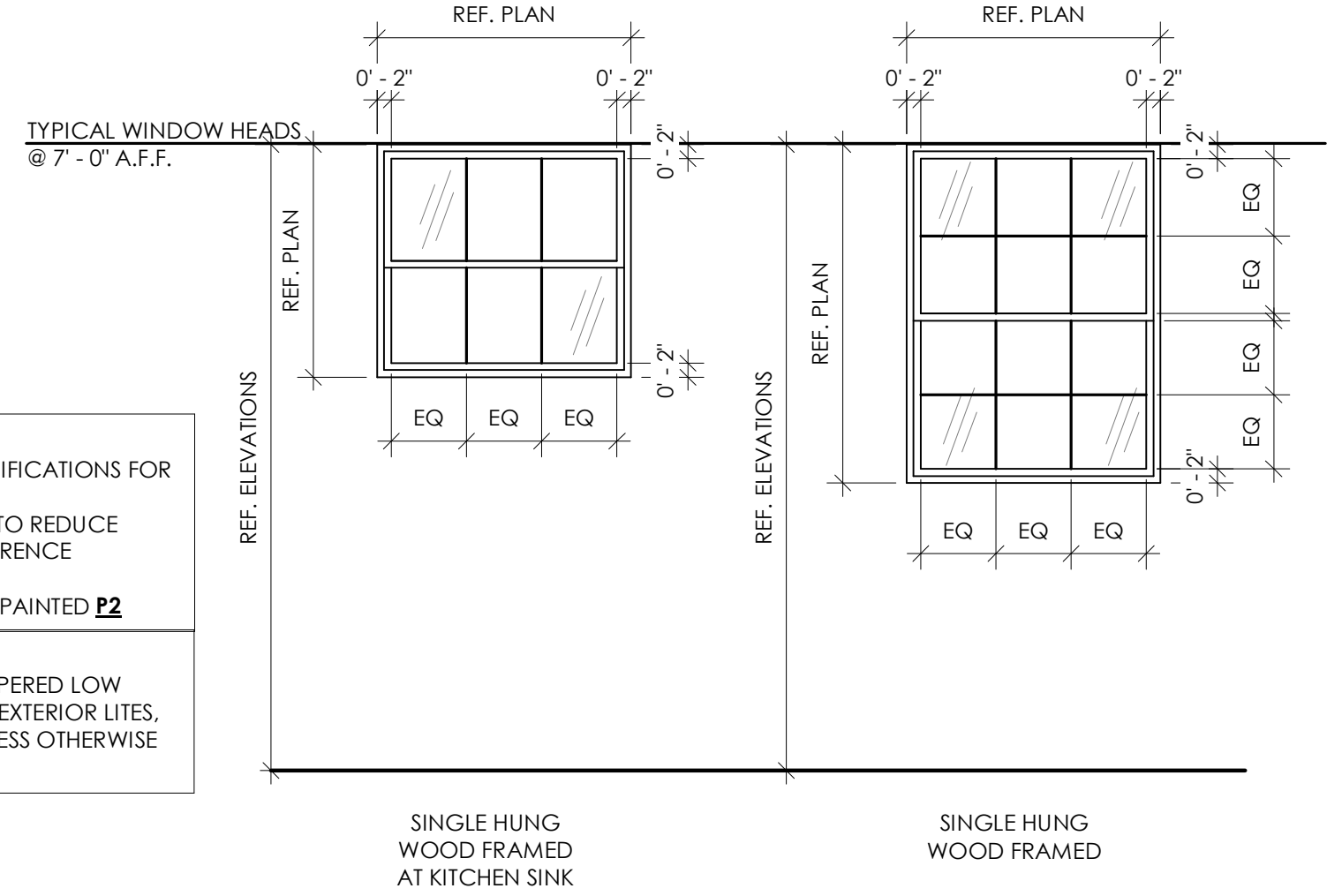

**C** WINDOW ELEVATIONS  
1/2" = 1'-0"

**SPECIALTIES SCHEDULE LEGEND**

**CPCI:** CONTRACTOR PROVIDED, CONTRACTOR INSTALLED  
**CPOI:** CONTRACTOR PROVIDED, OWNER INSTALLED  
**OPOI:** OWNER PROVIDED, OWNER INSTALLED  
**OPCI:** OWNER PROVIDED, CONTRACTOR INSTALLED

MARK	DESCRIPTION	MFG.	MFG. #	DIMENSIONS	FINISH	RESPONSIBILITY	REMARKS
<b>DIVISION 6 - ARCHITECTURAL WOODWORK</b>							
BR1	METAL COUNTER SUPPORT BRACKET	TMI SYSTEMS	A7453	3"W x AS REQUIRED	MATCH ADJACENT WALL COLOR	CPCI	PROVIDE BLOCKING AS REQUIRED
<b>DIVISION 10 - APPLIANCES</b>							
DRY	DRYER	BY OTHERS	BY OTHERS	BY OTHERS	BY OTHERS	OPOI	PROVIDE POWER AND EXHAUST
DW	DISHWASHER	BY CONTRACTOR	BY CONTRACTOR	BY CONTRACTOR	BY CONTRACTOR	CPCI	PROVIDE NECESSARY PLUMBING
GD1	GARBAGE DISPOSAL	BY CONTRACTOR	BY CONTRACTOR	BY CONTRACTOR	BY CONTRACTOR	CPCI	PROVIDE NECESSARY PLUMBING
REF	REFRIGERATOR	AMANA	ART308FFDW	30"W X 29"D X 66"H	STAINLESS STEEL	CPCI	PROVIDE NECESSARY PLUMBING AND POWER
RG	RANGE & OVEN	AMANA	AER6603SMS	30"W X 28"D X 47"H	STAINLESS STEEL	CPCI	PROVIDE NECESSARY PLUMBING AND POWER
WASH	WASHER	BY OTHERS	BY OTHERS	BY OTHERS	BY OTHERS	OPOI	PROVIDE NECESSARY PLUMBING
<b>DIVISION 10 - FIRE PROTECTION SPECIALTIES</b>							
FE	FIRE EXTINGUISHER	LARSEN'S	RE: SPECS	RE: SPECS	-	CPCI	LOCATE UNDER KITCHEN SINK
<b>DIVISION 10 - TOILET AND BATH ACCESSORIES</b>							
G8	SHOWER GRAB BAR	ASI	3550	1 1/2" dia	STAINLESS STEEL	CPCI	PROVIDE BLOCKING AS REQUIRED
M1	MIRROR	BY CONTRACTOR	BY CONTRACTOR	48"W X 30"H	GLASS	CPCI	PROVIDE BLOCKING AS REQUIRED
M2	MIRROR	BY CONTRACTOR	BY CONTRACTOR	60" W X 30"H	GLASS	CPCI	PROVIDE BLOCKING AS REQUIRED
M3	MIRROR	BY CONTRACTOR	BY CONTRACTOR	36" W X 30"H	GLASS	CPCI	PROVIDE BLOCKING AS REQUIRED
RD1	SHOWER CURTAIN ROD	ZENNA HOME	72F2ALBNL	ADJUSTABLE	SATIN STAINLESS STEEL	CPCI	PROVIDE BLOCKING AS REQUIRED
SS1	MOBILE SHOWER SEAT	BY CONTRACTOR	BY CONTRACTOR	---	WHITE	CPCI	PROVIDE BLOCKING AS REQUIRED
TD1	TOILET TISSUE DISPENSER	FRANKLIN BRASS	MAX51-SN	7"L	STAINLESS STEEL	CPCI	PROVIDE BLOCKING AS REQUIRED
TWBR	TOWEL BAR	FRANKLIN BRASS	MAX18-SN	18" L	STAINLESS STEEL	CPCI	PROVIDE BLOCKING AS REQUIRED
TWRG	TOWEL RING	FRANKLIN BRASS	MAX46-SN	8" L	STAINLESS STEEL	CPCI	PROVIDE BLOCKING AS REQUIRED
<b>DIVISION 22 - PLUMBING FIXTURES</b>							
BS	BATHTUB SURROUND	STERLING	71374800-0	60"W X 30"D X 73"	WHITE	CPCI	PROVIDE BLOCKING AS REQUIRED
F1	KITCHEN FAUCET	MOEN	87233SR5	14.5"H	NICKEL	CPCI	PROVIDE NECESSARY PLUMBING
F3	BATHROOM FAUCET	MOEN	84603SRN	-	NICKEL	CPCI	PROVIDE NECESSARY PLUMBING
S1	KITCHEN SINK	ELKAY	LWDB332284N	33"W X 22"D S 8"H	STAINLESS STEEL	CPCI	PROVIDE NECESSARY PLUMBING
S2	KITCHEN SINK ADA	AMERICAN STANDARD	20DB.8332284S.075	33"W X 22"D S 8"H	STAINLESS STEEL	CPCI	PROVIDE NECESSARY PLUMBING
S3	BATHROOM SINK	AQUASOURCE	ML-20507-B	19"W X 19"D X 8.3"H	WHITE	CPCI	PROVIDE NECESSARY PLUMBING
SH0	BATHTUB	STERLING	71341810-0	60"W X 29"D X 17.25"H	WHITE	CPCI	PROVIDE NECESSARY PLUMBING
SHC	SHOWER CONTROLS, FAUCET, AND HEAD	DELTA	BT13410-SS	-	STAINLESS STEEL	CPCI	PROVIDE NECESSARY PLUMBING
SHH	SHOWER HEAD ADA	DELTA	75490	-	STAINLESS STEEL	CPCI	PROVIDE NECESSARY PLUMBING
SW	SHOWER SURROUND	SWAN	SS0489601.011	48"W X 96"H X .25"D	WHITE	CPCI	PROVIDE BLOCKING AS REQUIRED
T	TOILET	AMERICAN STANDARD	731AA001S.20	18"W X 31.25D X 31"H	WHITE	CPCI	PROVIDE NECESSARY PLUMBING
<b>DIVISION 26 - ELECTRICAL FIXTURES</b>							
HVL	HEAT VENT LIGHT	UTILITECH	7123-02-L	11"S X 15"D X 6"H	WHITE	CPCI	PROVIDE POWER AND EXHAUST
LC	CAN LIGHT	UTILITECH	MGTL1116-L10.5K9027	7.5"DIA X 3"H	WHITE	CPCI	PROVIDE POWER AS REQUIRED
LD	DOME LIGHT	DESIGNERS FOUNTAIN	1360M-BN	14"DIA X 5"H	NICKEL	CPCI	PROVIDE POWER AS REQUIRED
LF	FAN WITH LIGHT KIT	KICHLER	30004485S	56"DIA X 16"H	STAINLESS STEEL	CPCI	PROVIDE POWER AS REQUIRED
LS	SECURITY LIGHT	LITHONIA	OFTH300PR120WHM12	5"W X 6"D X 5"H	WHITE	CPCI	PROVIDE POWER AS REQUIRED
LW	EXTERIOR WALL LIGHT	LITEC	5510808001	5"W X 4"D X 6"H	STAINLESS STEEL	CPCI	PROVIDE POWER AS REQUIRED

**DOOR SCHEDULE NOTES**

- USE 1" INSULATED CLEAR TEMPERED LOW EMISSIVITY GLAZING ON ALL EXTERIOR LITES, UNLESS OTHERWISE NOTED
- ALL DOORS AND FRAMES TO BE PAINTED **P2**

**DOOR HARDWARE NOTES**

- ALL DOORS TO RECEIVE HARDWARE ON BOTH SIDES
- ALL EXTERIOR DOORS AND GARAGE DOOR TO RECEIVE LOCKABLE HARDWARE. KEYED DEADBOLT, LEVER HANDLE LATCH
- BATH ROOM AND BEDROOM DOORS TO RECEIVE NON-KEYED "THUMB PRESS" ONE SIDED LOCK ON LEVER.

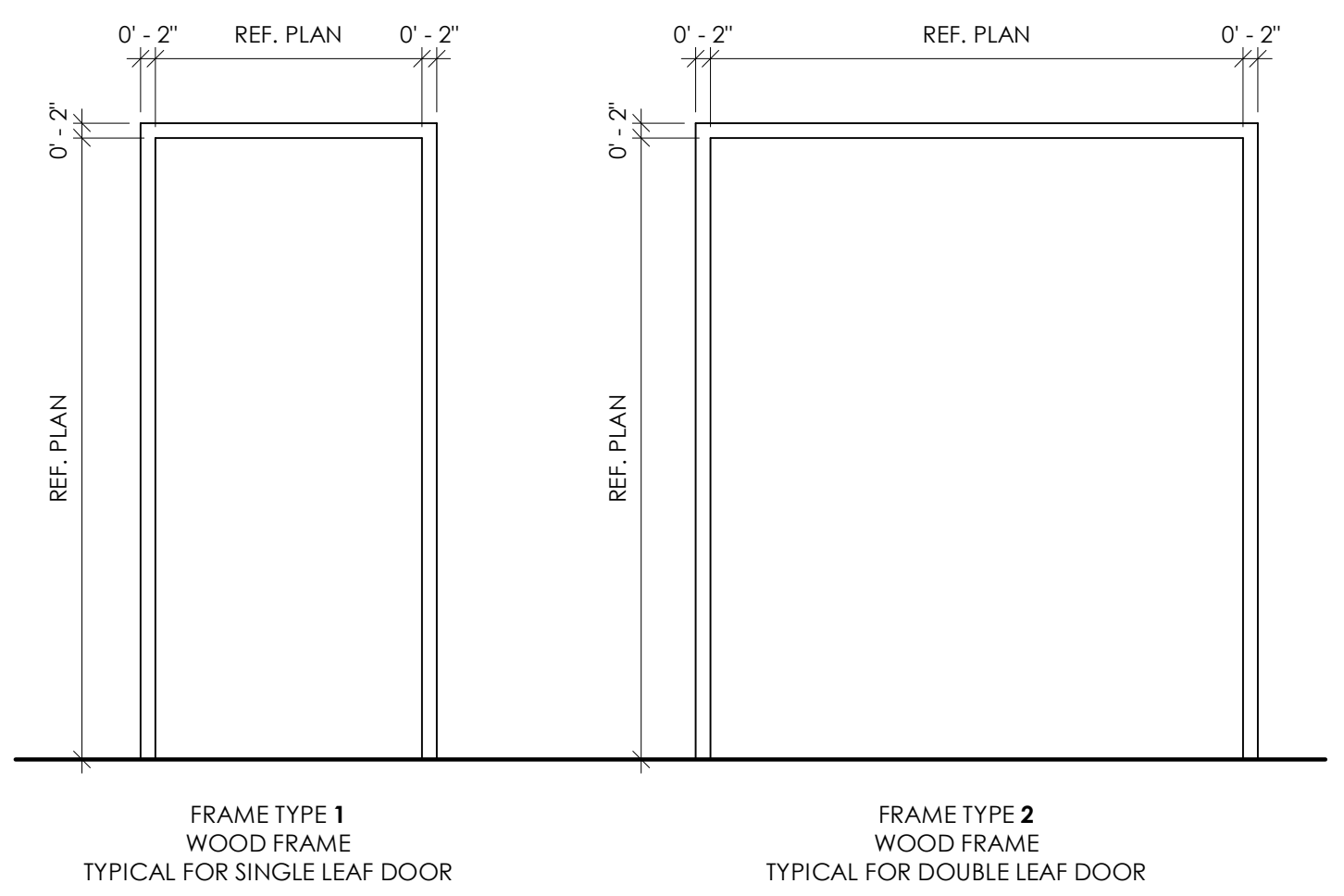

**B** DOOR FRAME ELEVATIONS  
1/2" = 1'-0"

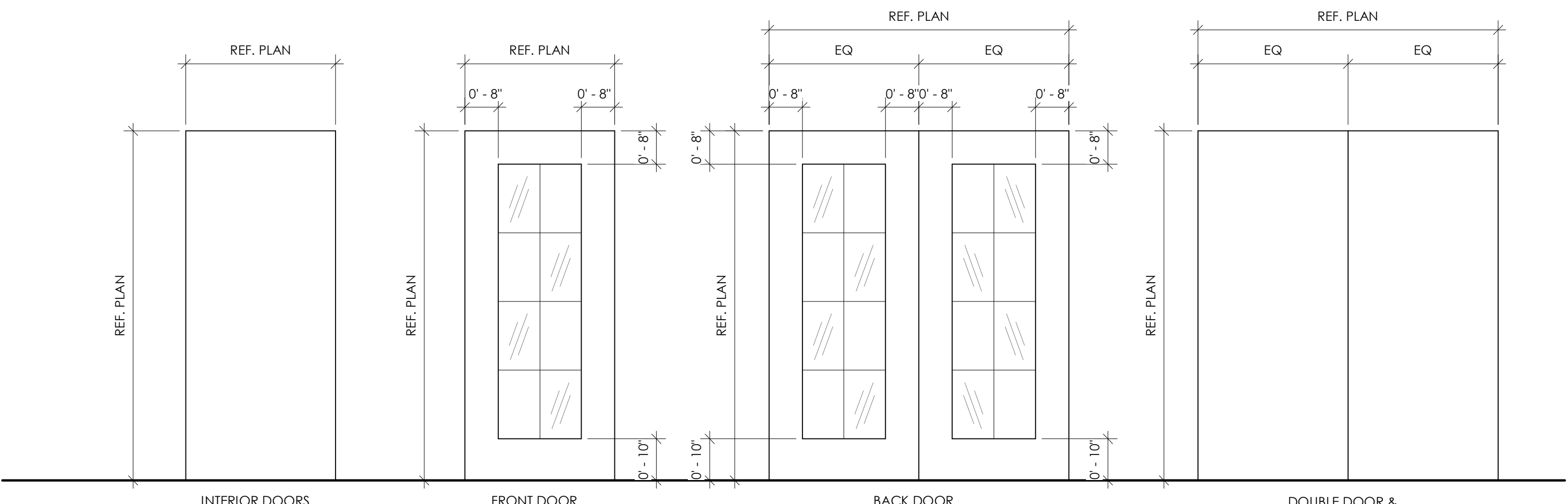

**A** DOOR ELEVATIONS  
1/2" = 1'-0"

**SINGLE FAMILY HOME  
3 BR ADA HOME**

HOUSING AUTHORITY OF  
THE CHEROKEE NATION

N. SHERIDAN RD. & E. 136TH ST. N.  
COLLINSVILLE, OK

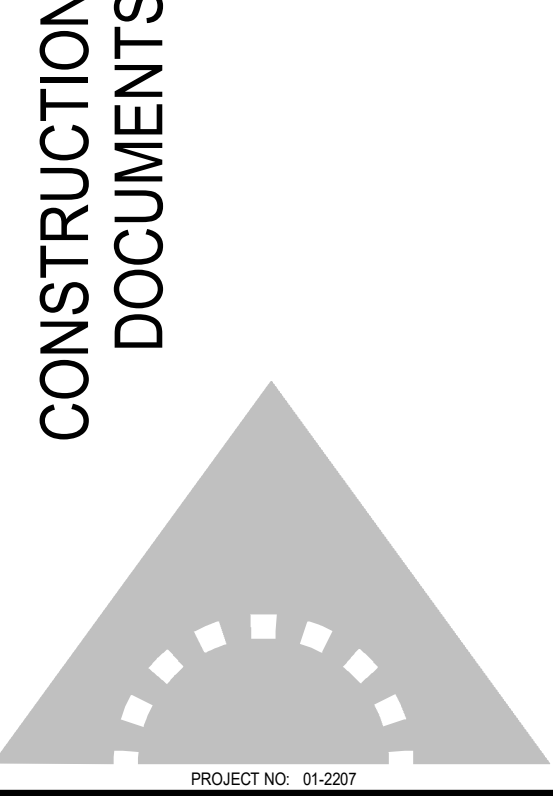
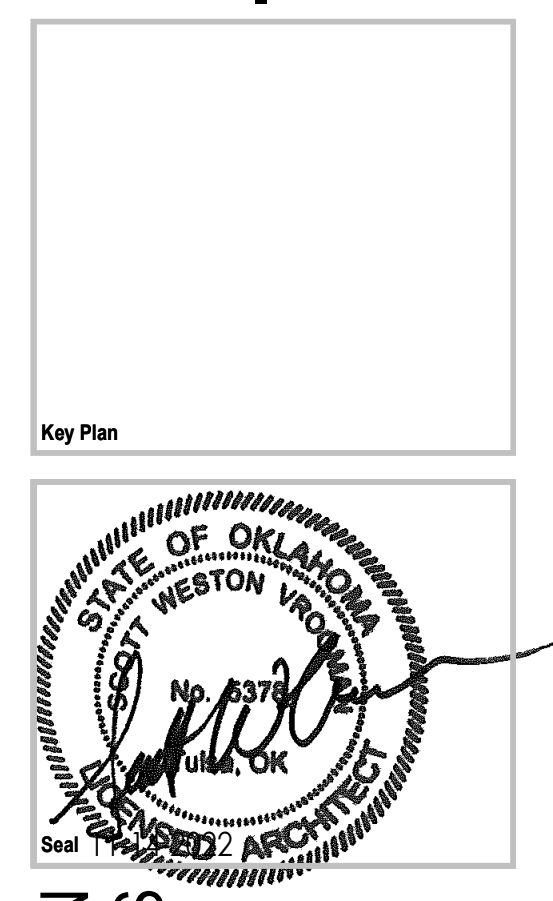

SHEET TITLE: **SPECIALTIES, DOORS & WINDOWS**

DRAWN BY: Author  
CHECKED BY: Checker  
ISSUE DATE: 2-14-2022

**A500**

PRINT THIS SHEET FULL SIZE (11" X 17")





1 FLOOR & WALL FINISHES PLAN A  
1/4" = 1'-0"

A FINISH SCHEDULE					
ROOM #	Name	Area	Floor Finish	Wall Finish	Comments
100	FRONT PORCH	75 SF	LVT1	P1	
101	FOYER	52 SF	LVT1	P1	
102	CORR	77 SF	LVT1	P1	
103	BEDROOM	142 SF	LVT1	REF. FINISH PLAN	
104	CL	17 SF	LVT1	P1	
105	BEDROOM	119 SF	LVT1	REF. FINISH PLAN	
106	CL	20 SF	LVT1	P1	
107	BATH	65 SF	T2	REF. ELEVATIONS	1; 2; 3; 6; 9
108	BEDROOM	187 SF	LVT1	REF. FINISH PLAN	
109	BATH	75 SF	T2	REF. ELEVATIONS	1; 2; 3; 6; 9
110	CL	37 SF	LVT1	P1	
111	GREAT ROOM	281 SF	LVT1	REF. ELEVATIONS	
112	KITCHEN	144 SF	T1	REF. ELEVATIONS	1; 3; 6; 9
113	PANTRY	6 SF	T1	P1	
114	DINING	135 SF	T1	P1	
115	LAUNDRY	47 SF	LVT1	P1	
116	2 CAR GARAGE	405 SF	SC	P1	
117	MECH	26 SF	SC	P1	
118	BACK PORCH	169 SF			

ROOM FINISH LEGEND		
<b>FLOORING</b>	<p><b>LVT1</b> MANUFACTURER: PATCRAFT STYLE: HOMEGRAN COLOR: VERANDA 00110 SIZE: 6" X 48" <b>INSTALLATION:</b> STAGGERED</p> <p><b>SC</b> SEALED CONCRETE MANUFACTURER: CROSSVILLE STYLE: PORTUGAL COLOR: HARVEST TAWNY SIZE: 12" X 24" <b>INSTALLATION:</b> BRICK <b>GROUT: MAPEI</b> ; COLOR: SILVER 27</p> <p><b>T1</b> MANUFACTURER: CROSSVILLE STYLE: PORTUGAL COLOR: HARVEST TAWNY SIZE: 12" X 24" <b>INSTALLATION:</b> BRICK <b>GROUT: MAPEI</b> ; COLOR: SILVER 27</p> <p><b>T2</b> MANUFACTURER: CROSSVILLE STYLE: PORTUGAL COLOR: VEHNO VERDE SIZE: 12" X 24" <b>INSTALLATION:</b> BRICK <b>GROUT: MAPEI</b> ; COLOR: WARM GRAY 93</p> <p><b>T3</b> MANUFACTURER: CROSSVILLE STYLE: PORTUGAL COLOR: VEHNO VERDE SIZE: 12" X 24" <b>INSTALLATION:</b> BRICK <b>GROUT: MAPEI</b> ; COLOR: WARM GRAY 93</p> <p><b>WALL TILE</b> <b>WT1</b> MANUFACTURER: MOSA STYLE: COLORS COLOR: LIGHT GREY 6400 SIZE: 10CM X 30CM <b>INSTALLATION:</b> BRICK <b>GROUT: MAPEI</b> ; COLOR: FROST 77</p>	<p><b>ALL INTERIOR PAINT COLORS TO BE REVIEWED AND VERIFIED BY OWNER, IN WRITING, WITH PHYSICAL SAMPLE MOCK UPS AT LEAST 3' - 0" X 3' - 0" IN SIZE EVALUATED IN AN INTERIOR SPACE UNDER LIGHTING CONDITIONS SIMILAR TO THE FINISHED PROJECT. OWNER'S WRITTEN ACCEPTANCE OF SAMPLE IS REQUIRED PRIOR TO ORDERING INTERIOR PAINT.</b></p> <p><b>PAINT</b> <b>P1</b> MANUFACTURER: SHERWIN WILLIAMS COLOR: ICE CUBE SW6252 FINISH: EGGSHELL FOR WALLS; EPOXY FOR BATHROOM CEILINGS; FLAT FOR ALL OTHER CEILINGS</p> <p><b>P2</b> MANUFACTURER: SHERWIN WILLIAMS COLOR: ATTITUDE GRAY SW7060 FINISH: EGGSHELL FOR WALLS; EPOXY FOR BATHROOM WALLS; SEMI-GLOSS FOR DOORS AND TRIM</p> <p><b>MILLWORK</b> <b>PL1</b> MANUFACTURER: FORMICA COLOR: NEOCLOUD FINISH: INFINITI</p> <p><b>ST1</b> MANUFACTURER: MIXWAX COLOR: ALLUVIUM MW417</p>
<b>BASE</b>	<p><b>WB1</b> STYLE: 1x4" WOOD BASE BOARD COLOR: <b>P2</b></p> <p><b>TB1</b> MANUFACTURER: CROSSVILLE STYLE: PORTUGAL COLOR: HARVEST TAWNY SIZE: 6" X 24" <b>INSTALLATION:</b> BULLNOSE <b>GROUT: MAPEI</b> ; COLOR: SILVER 27</p> <p><b>TB2</b> MANUFACTURER: CROSSVILLE STYLE: PORTUGAL COLOR: VEHNO VERDE SIZE: 4" X 24" <b>INSTALLATION:</b> BULLNOSE <b>GROUT: MAPEI</b> ; COLOR: WARM GRAY 93</p>	<p><b>CEILING</b> <b>GYP.</b> GYPSUM WALL BOARD FINISH: PAINT <b>P1</b></p> <p><b>MISCELLANEOUS</b> <b>BO</b> BY OTHERS <b>FRP1</b> BATHTUB AND SHOWER SURROUND, REF SPECIALTIES SCHEDULE</p> <p><b>KEYED FINISH REMARKS:</b></p> <ol style="list-style-type: none"> <li>PROVIDE APPROPRIATE SCHLUTER TRANSITION STRIPS AT ALL FLOORING CHANGES.</li> <li><b>FRP1</b> TO BE USED ON WALLS IN SHOWER/TUB AREAS.</li> <li>ALL WALLS TO BE PAINTED <b>P1</b> UNLESS NOTED OTHERWISE. REFER TO ELEVATIONS AND FLOOR FINISH PLANS.</li> <li>ALL INTERIOR GYP WALLS TO BE <b>ORANGE PEEL</b> (LEVEL 3) FINISH</li> <li>ALL WALLS TO HAVE WOOD BASE <b>WB1</b> UNLESS NOTED OTHERWISE.</li> <li>KITCHEN WALL BASE TO BE <b>TB1</b>; BATHROOM WALL BASE TO BE <b>TB2</b></li> <li>ALL ELECTRICAL SWITCH, POWER, ETC., COVER PLATES TO BE WHITE</li> <li>ALL MILLWORK HARDWARE TO BE STAINLESS STEEL</li> <li>ALL MILLWORK BASE TO BE <b>ST1</b> UNLESS NOTED OTHERWISE</li> </ol>

Purpose. Driven. Architecture.

618 E. 3rd St.  
Tulsa, OK 74103  
918.743.2724 (M)  
918.743.2725 (F)

No. \_\_\_\_\_ Description \_\_\_\_\_ Date \_\_\_\_\_

REVISIONS

Consultants

# SINGLE FAMILY HOME 3 BR ADA HOME

HOUSING AUTHORITY OF  
THE CHEROKEE NATION

N. SHERIDAN RD. & E. 136TH ST. N.  
COLLINSVILLE, OK

STATE OF OKLAHOMA  
WESTON WOODS ARCHITECTS  
No. 8572  
Tulsa, OK  
Professional Architect

CONSTRUCTION DOCUMENTS

PROJECT NO. 01-2207

SHEET TITLE: FLOOR & WALL FINISH PLAN

DRAWN BY: Author  
CHECKED BY: Checker  
ISSUE DATE: 2-14-2022

# A600

No.	Description	Date

REVISIONS

Consultants

# SINGLE FAMILY HOME 3 BR ADA HOME

HOUSING AUTHORITY OF  
THE CHEROKEE NATION  
N. SHERIDAN RD. & E. 136TH ST. N.  
COLLINSVILLE, OK

Key Plan

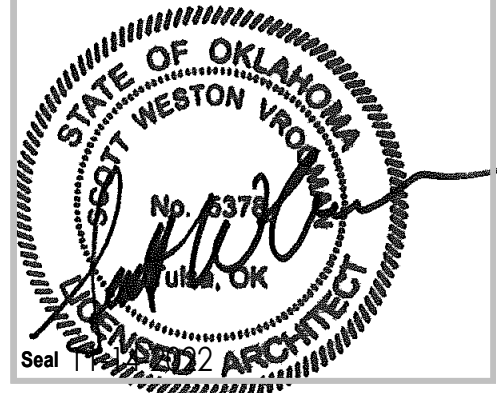

## CONSTRUCTION DOCUMENTS

PROJECT NO: 01-2207

SHEET TITLE: **INTERIOR ELEVATIONS**

Author  
Checked by  
Issue Date: 2-14-2022

# A610

PRINT THIS SHEET FULL SIZE AT 24" X 36"

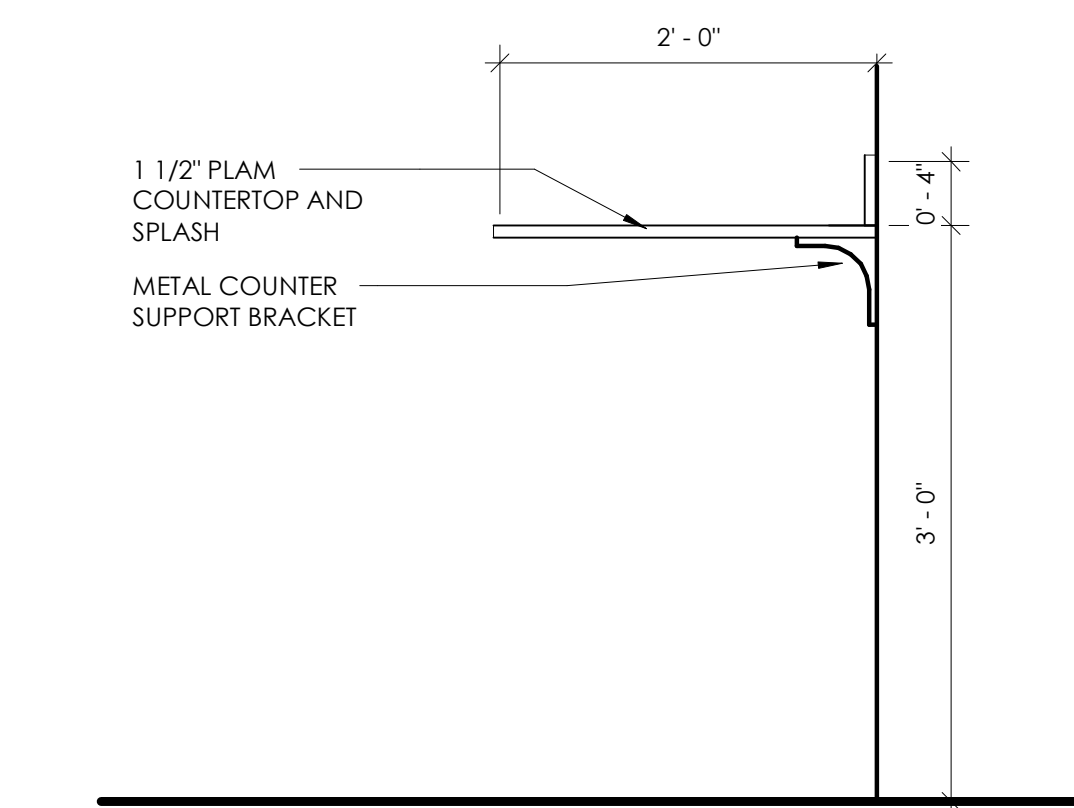

**S** TYPICAL LAUNDRY COUNTER  
1" = 1'-0"

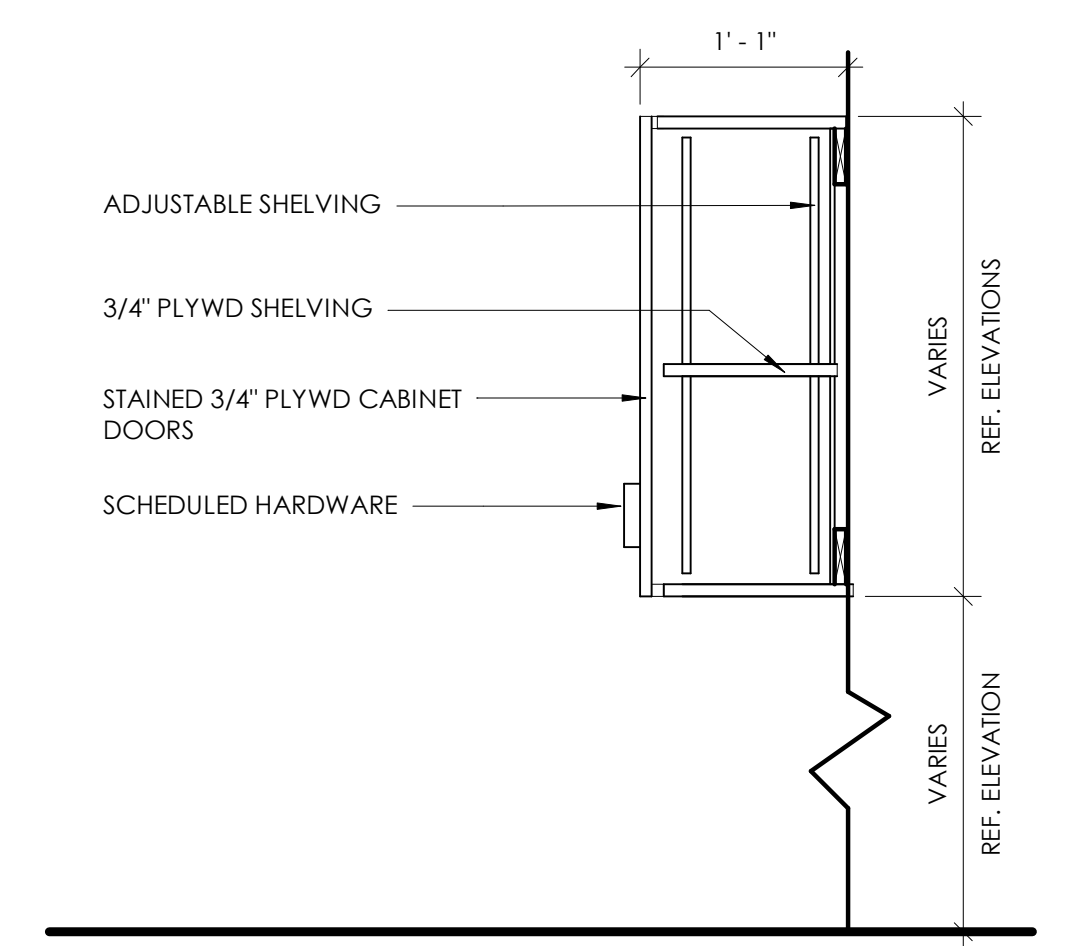

**N** TYPICAL UPPER CABINET  
1" = 1'-0"

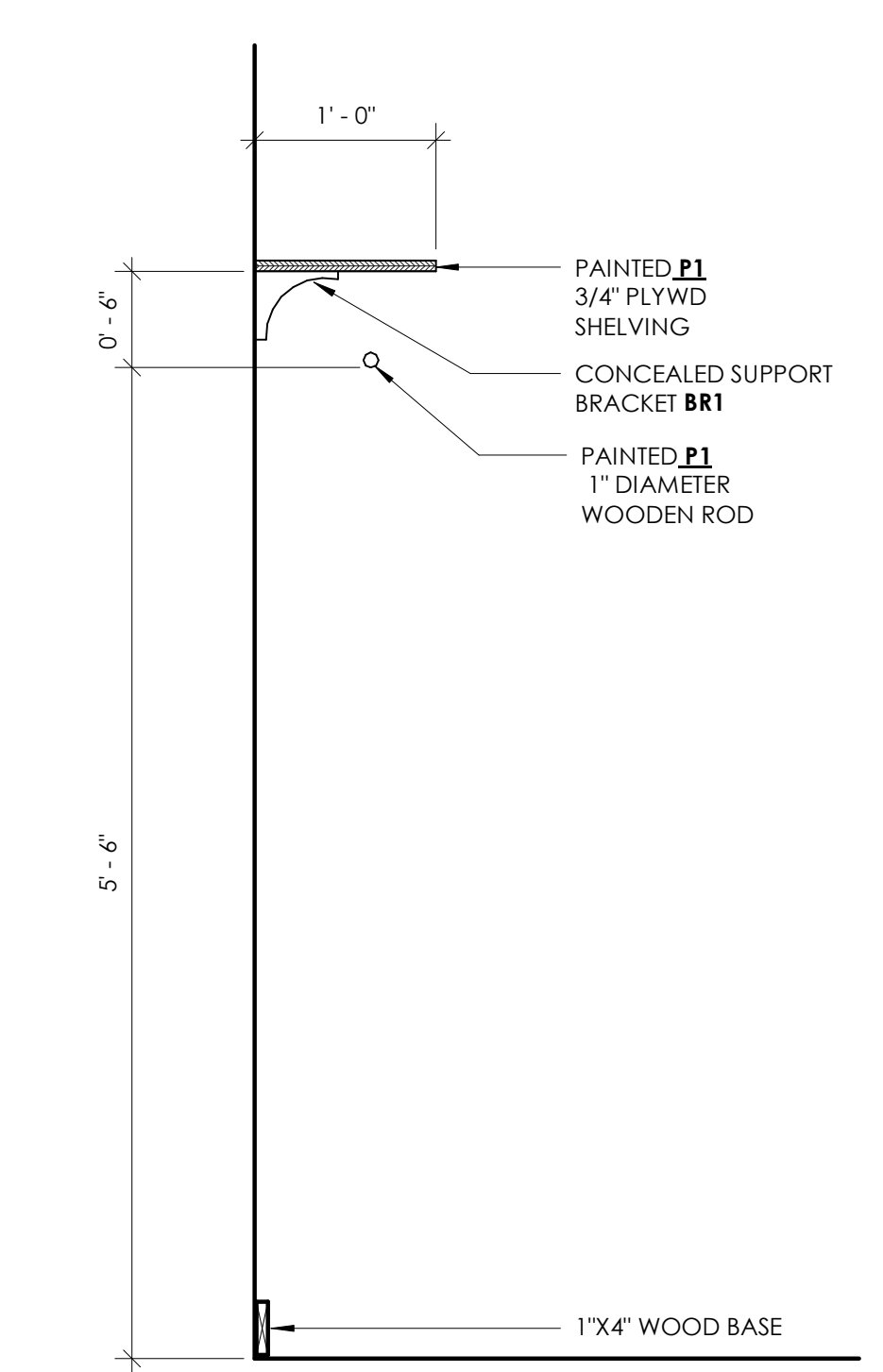

**R** TYPICAL CLOSET ROD & SHELF  
1" = 1'-0"

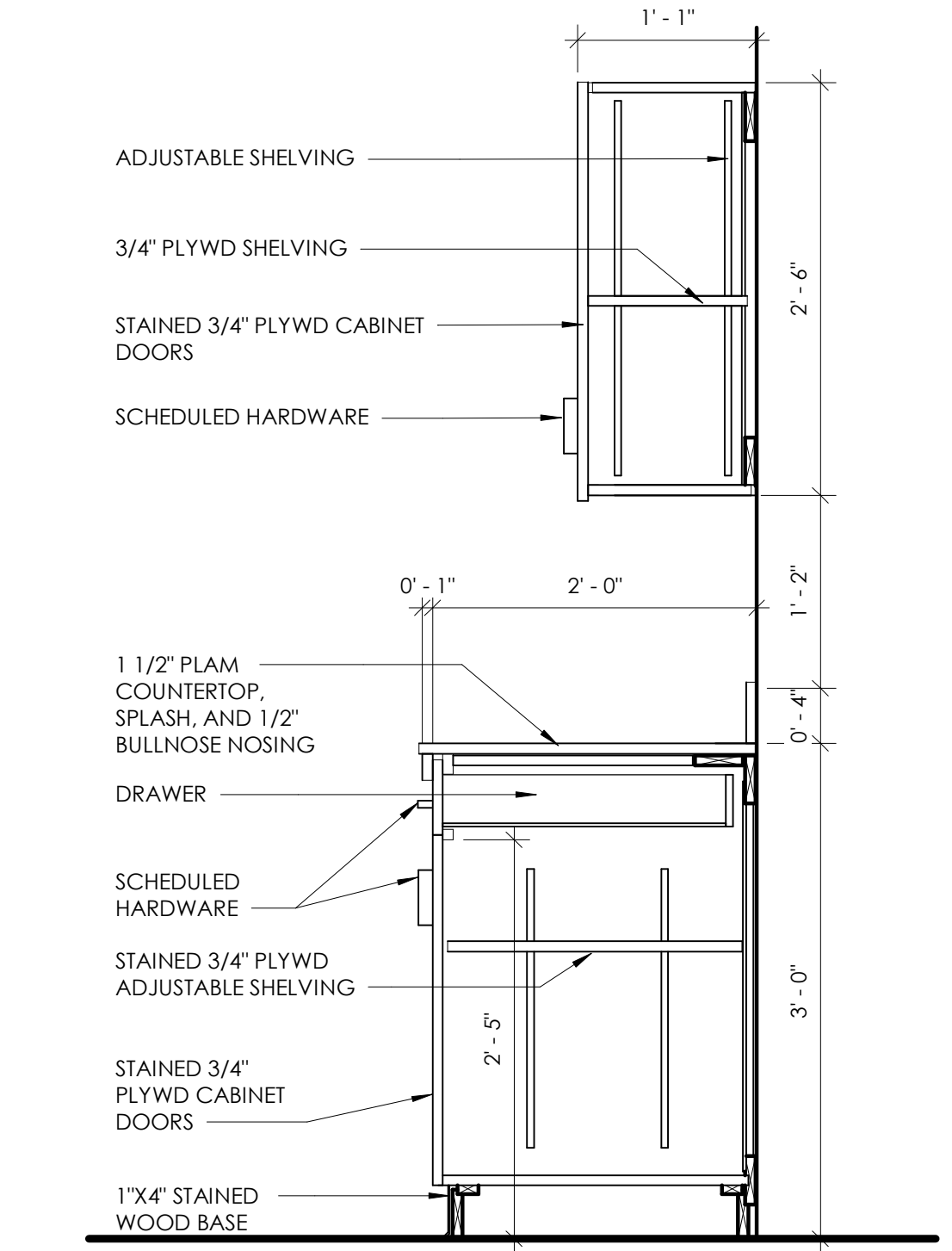

**Q** TYPICAL UPPER AND LOWER CABINET  
1" = 1'-0"

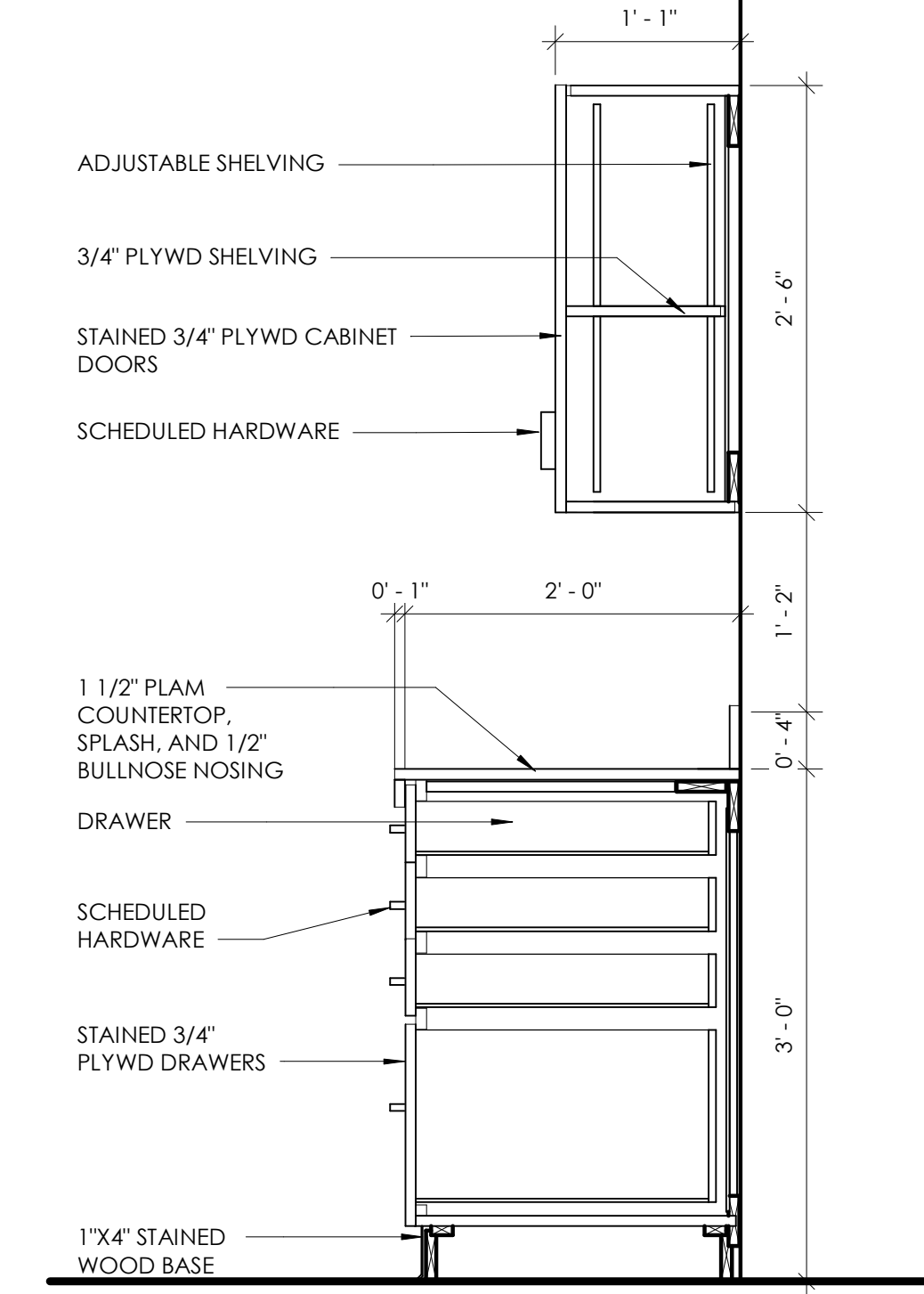

**P** TYPICAL UPPER AND LOWER DRAWERS  
1" = 1'-0"

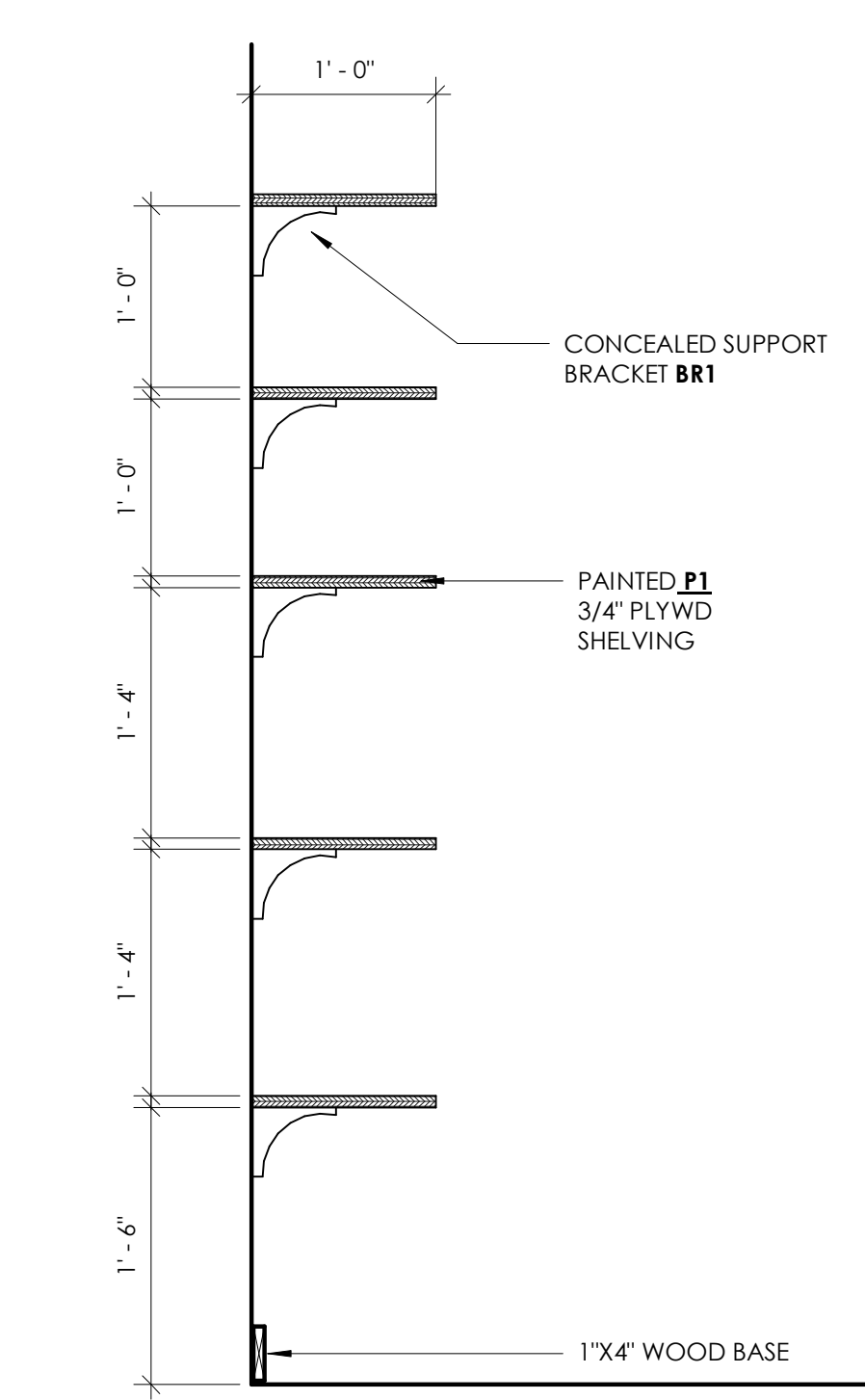

**O** TYPICAL PANTRY SHELVING  
1" = 1'-0"

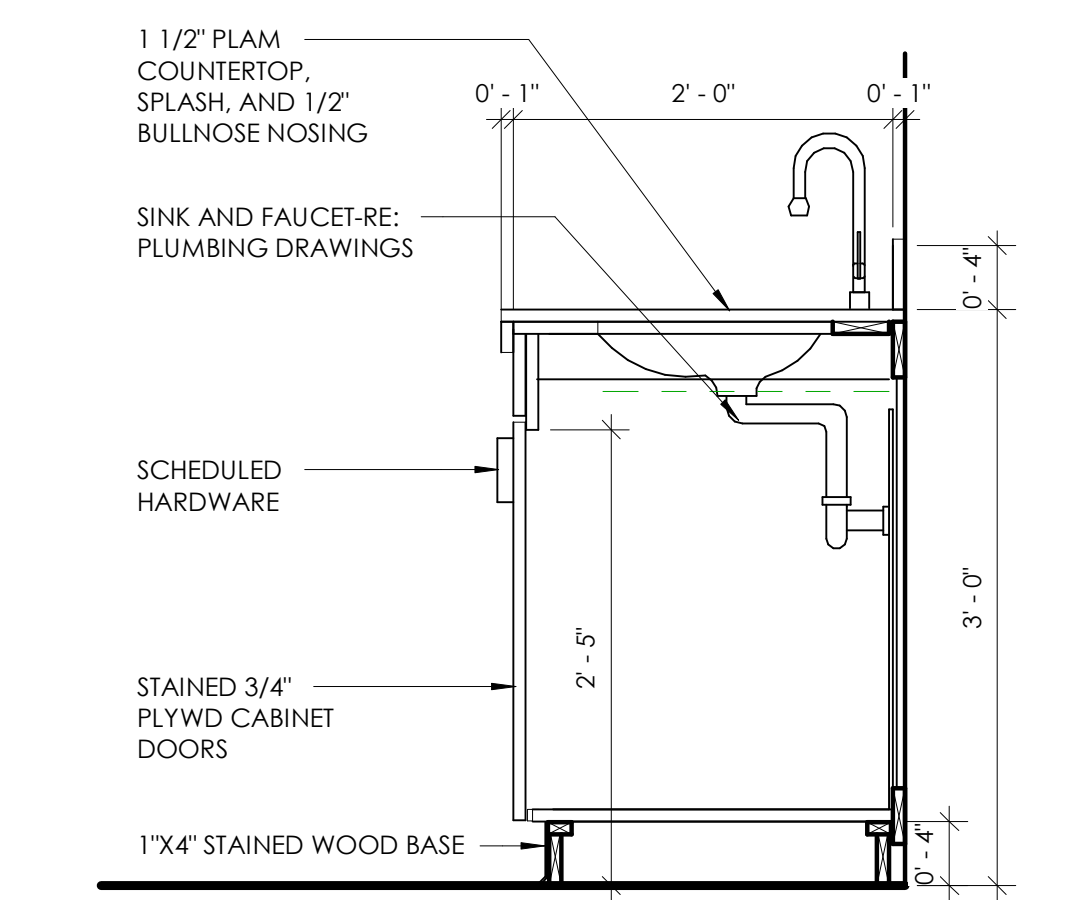

**M** TYPICAL SINK CABINET  
1" = 1'-0"

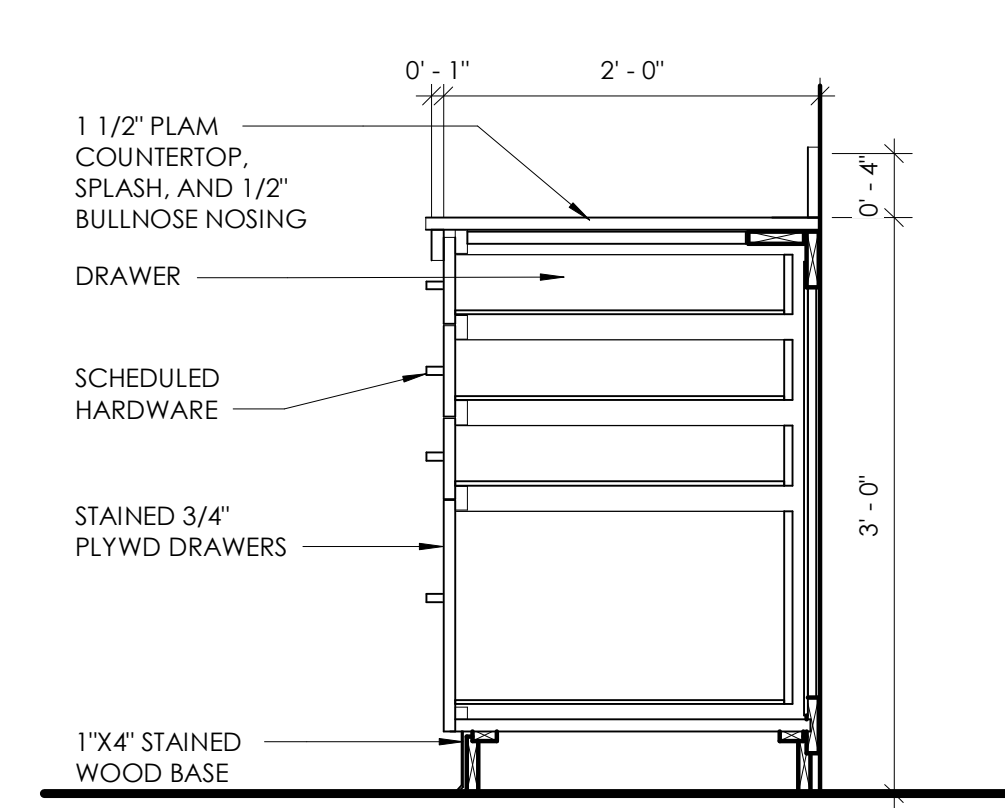

**L** TYPICAL LOWER DRAWERS  
1" = 1'-0"

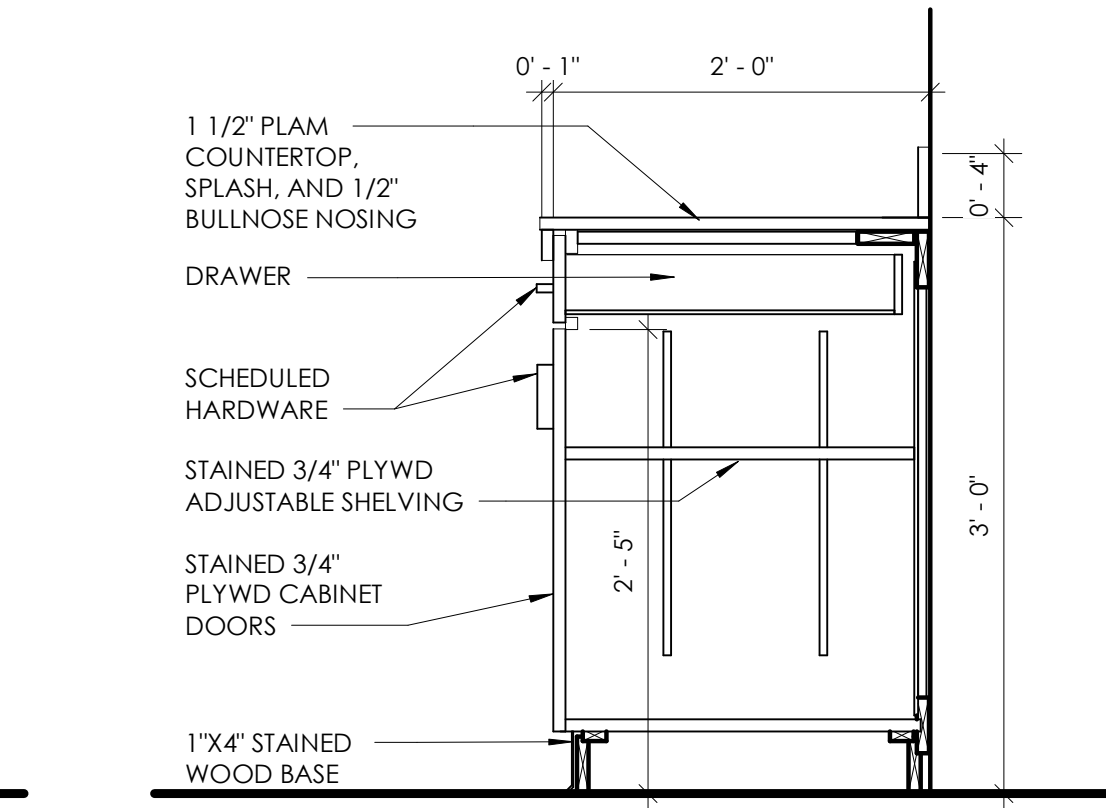

**K** TYPICAL LOWER CABINET  
1" = 1'-0"

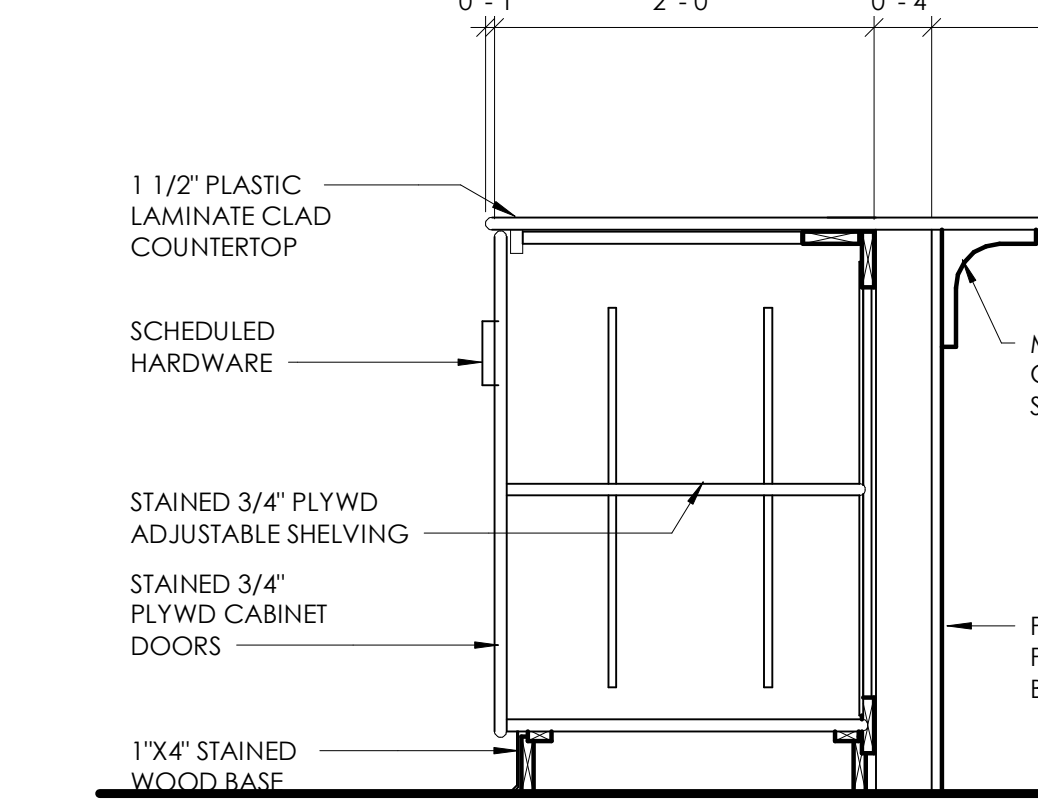

**J** TYPICAL KITCHEN ISLAND  
1" = 1'-0"

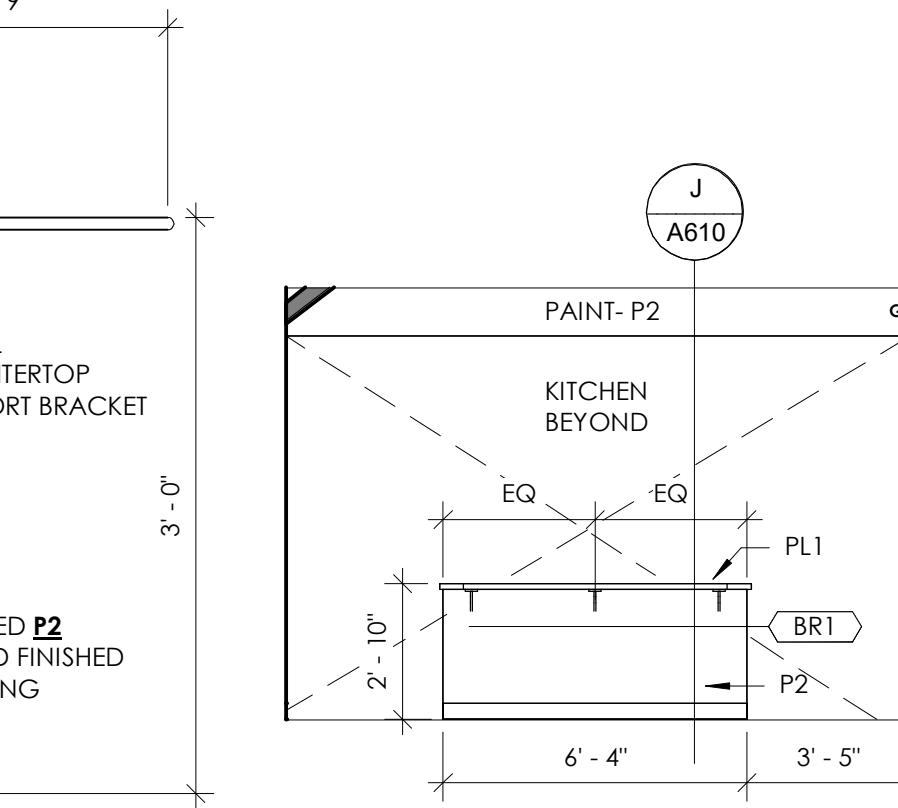

**I** KITCHEN 112 ISLAND BACK  
1/4" = 1'-0"

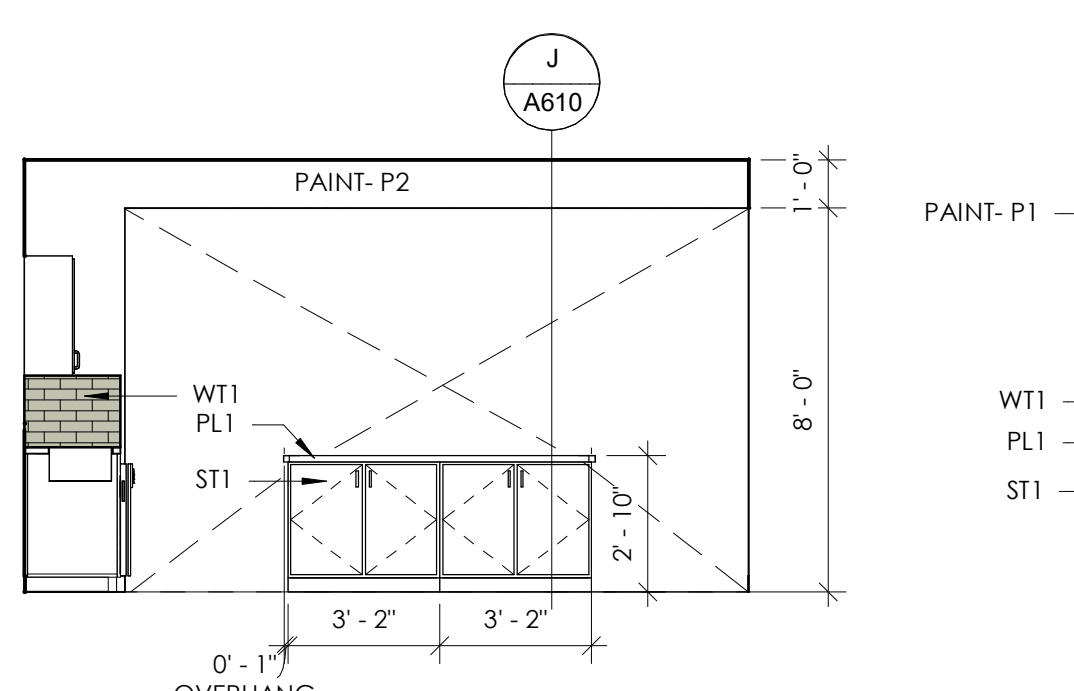

**H** KITCHEN 112 ISLAND FRONT  
1/4" = 1'-0"

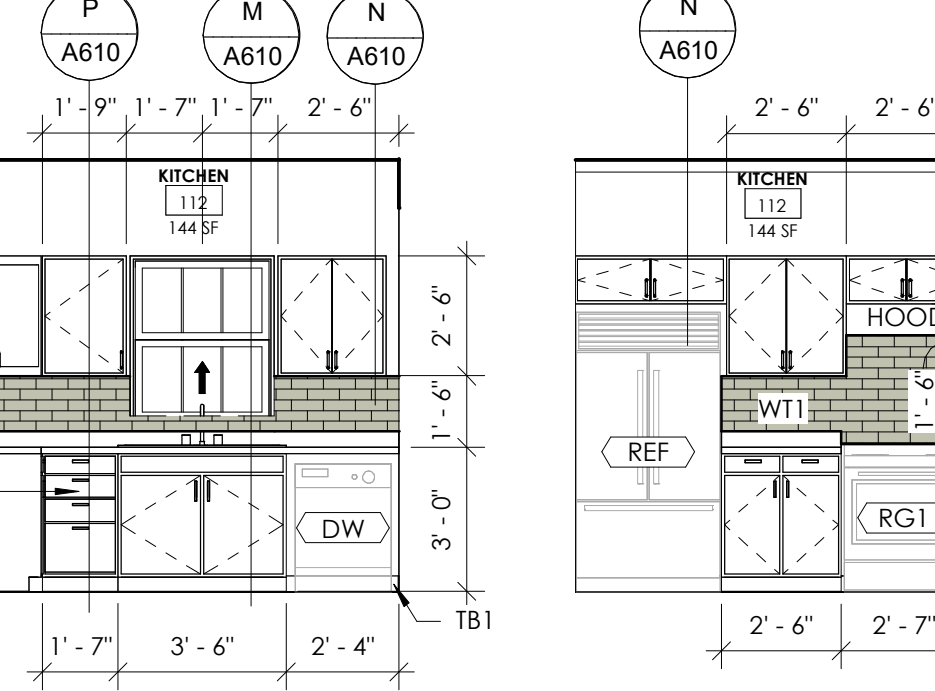

**G** KITCHEN 112 N  
1/4" = 1'-0"

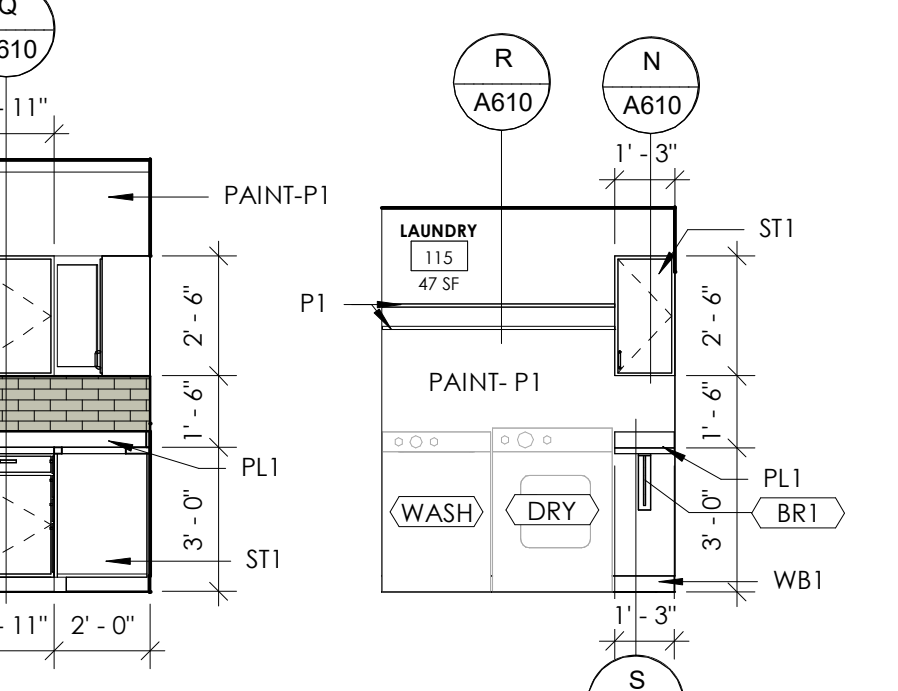

**F** KITCHEN 112 W  
1/4" = 1'-0"

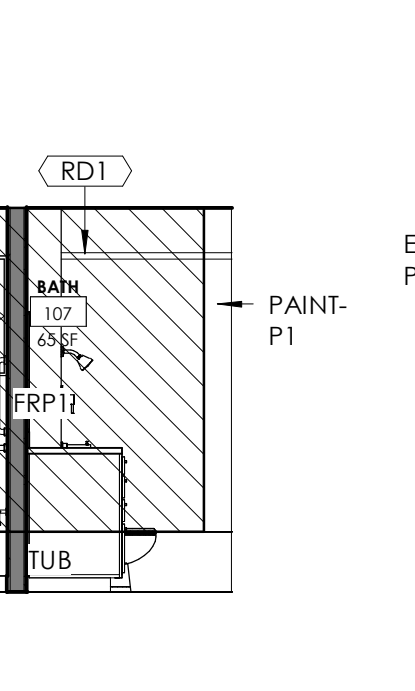

**E** LAUNDRY  
1/4" = 1'-0"

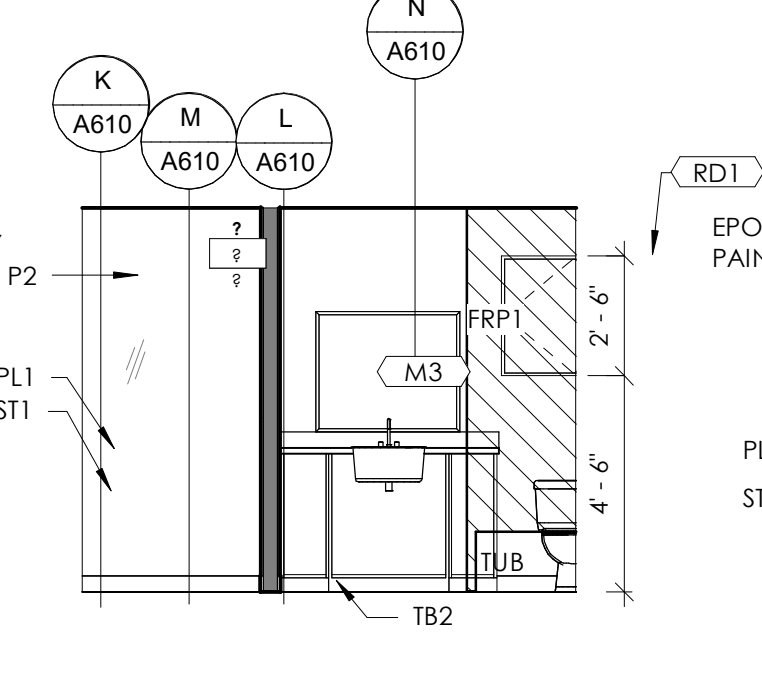

**D** BATH 107 E  
1/4" = 1'-0"

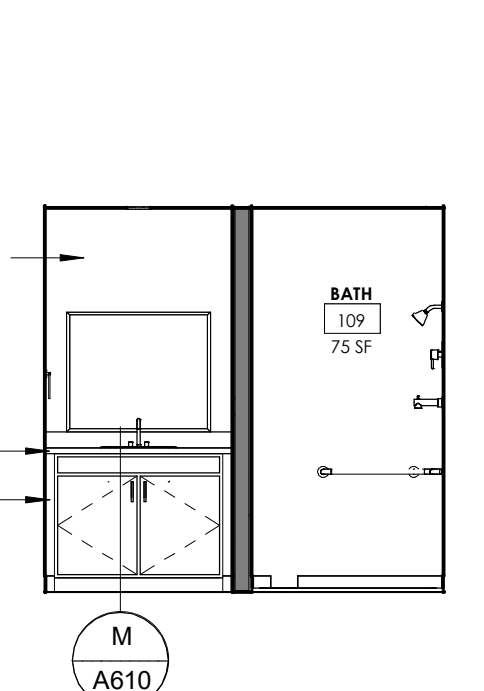

**C** BATH 107 N  
1/4" = 1'-0"

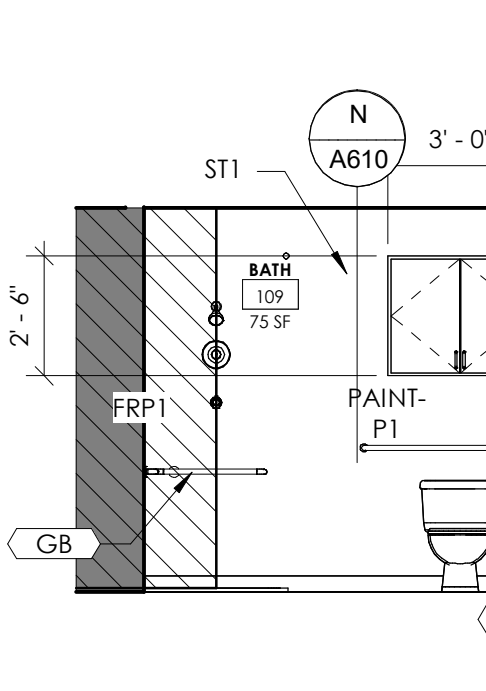

**B** BATH 109 N  
1/4" = 1'-0"

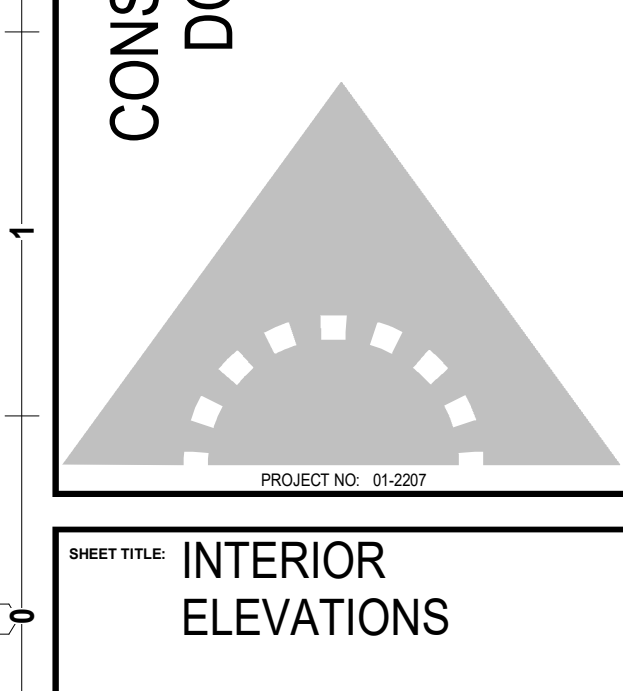

**A** BATH 109 E  
1/4" = 1'-0"

O N M L K J I H G F E D C B A

No.	Description	Date

REVISIONS

Consultants

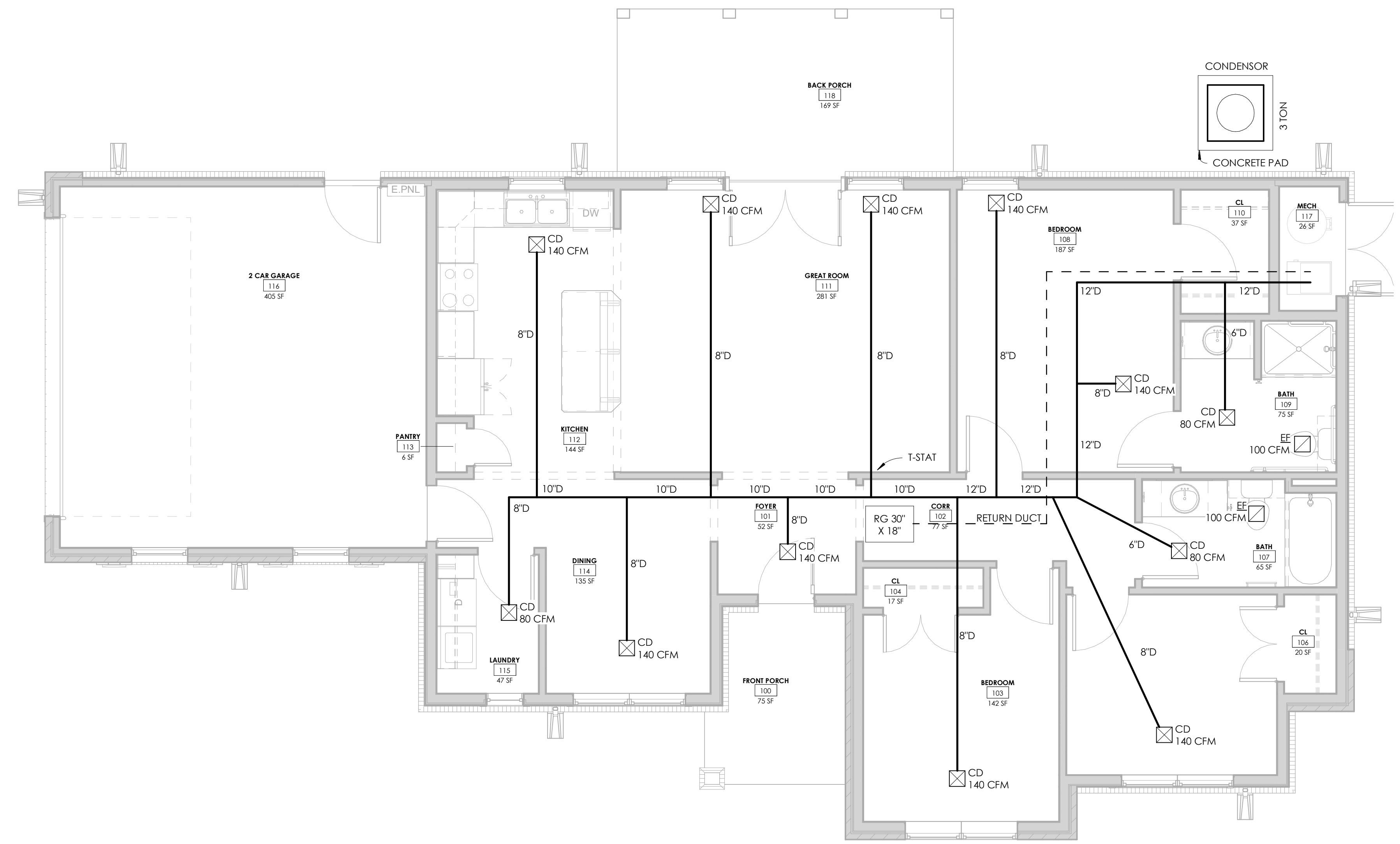

**AIR DEVICES NOTES**  
HART & COOLEY OR EQUAL

- CEILING DIFFUSERS TYPE 500
- 6X6 75 CFM OR LESS
  - 8X8 75 - 120 CFM
  - 10X10 120 - 175 CFM
  - 12X12 175 - 300 CFM

- SIDEWALL FURNACE (FAN COIL)  
RETURN GRILLE TYPE 672
- 30X12 800 CFM (2T)
  - 30X18 1200 CFM (3T)
  - 30X24 1600 CFM (4T)

- UNDERCUT DOORS NOTES
- UC = INDICATES DOOR IS UNDERCUT BY 1"
  - TYPICAL INTERIOR DOORS ARE ALL UNDERCUT, UNLESS INSTALLED IN AN INSULATED WALL.
  - EXTERIOR DOORS, AND DOORS TO GARAGES ARE NOT UNDERCUT.

- GENERAL HVAC NOTES:
1. USE HARD DUCT THROUGHOUT. NOT FLEX DUCT.
  2. VERIFY HEAT SOURCE WITH CONSTRUCTOR (GAS, **ELECTRIC RESISTANCE** AIR TO AIR HEAT PUMP)
  3. HEAT PUMP FAN COIL UNITS TO BE PROVIDED WITH SUPPLEMENTAL ELECTRIC HEATER (SIZED TO PROVIDE SUPPLY AIR TEMPERATURE ABOVE 95 DEGREE FORTHRIGHT WITH HEAT PUMP OPERATION AT 0 DEGREES FOR NIGHT OUTSIDE AIR TEMPERATURE)
  4. PROVIDE FLUE AND COMBUSTION AIR DUCTING FOR GAS FIRED FURNACE

**FURNACE NOTES**

- A. ESTIMATE 12,000 BTU PER 500 SF  
1025/500=3 3"1200"
  - B. **36,000 BTU MINIMUM SIZE**
2. INPUT FAN COIL (EH)-MIN 15kw, 2 STAGE FAN COIL (HTP)-MIN 10kw, 2 STAGE
  3. INSTALL FURNACE ON PLENUM STAND

**DRYER EXHAUST NOTES**

1. DRYER EXHAUST
  - A. INSTALL DRYER EXHAUST DUCT IN WALL BOX WITH BOTTOM OF BOX AT FLOOR LEVEL.
  - B. PROVIDE DRYER EXHAUST WALL CAP WITH BACK DRAFT DAMPER
  - C. 4" DIAMETER W/ TAPED JOINTS (NO SCREWS)

**SINGLE FAMILY HOME  
3 BR ADA HOME**

HOUSING AUTHORITY OF  
THE CHEROKEE NATION  
N. SHERIDAN RD. & E. 136TH ST. N.  
COLLINSVILLE, OK

Key Plan

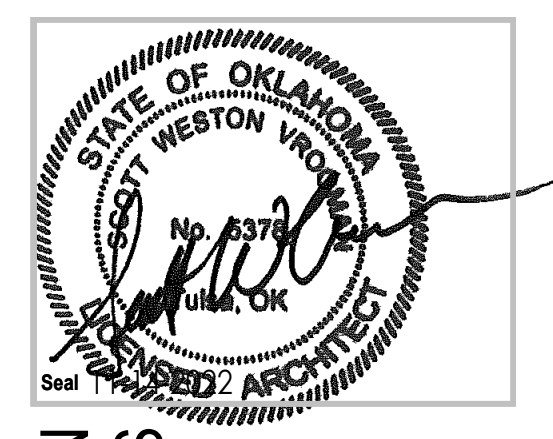

CONSTRUCTION  
DOCUMENTS

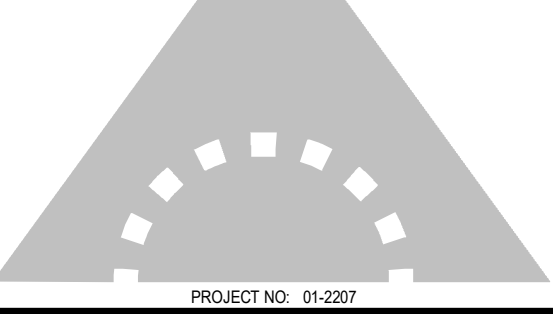

PROJECT NO: 01-2207

SHEET TITLE: MECHANICAL PLAN

DRAWN BY: Author  
CHECKED BY: Checker  
ISSUE DATE: 2 -14-2022

**M101**

**1 FLOOR PLAN - A (MECHANICAL)**  
1/4" = 1'-0"

No.	Description	Date

REVISIONS

Consultants

# SINGLE FAMILY HOME 3 BR ADA HOME

HOUSING AUTHORITY OF  
THE CHEROKEE NATION  
N. SHERIDAN RD. & E. 136TH ST. N.  
COLLINSVILLE, OK

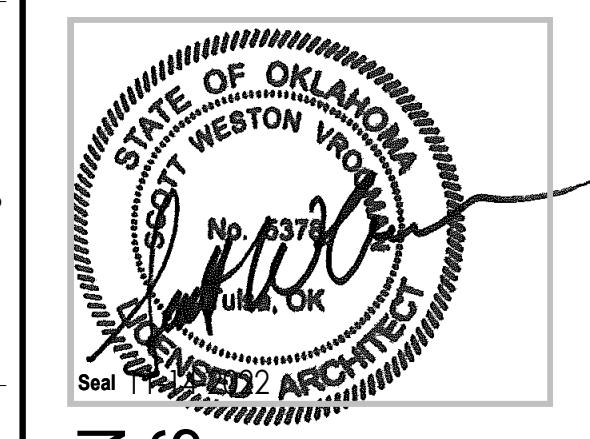

CONSTRUCTION DOCUMENTS

PROJECT NO. 01-2207

SHEET TITLE: PLUMBING PLAN

DRAWN BY: Author  
CHECKED BY: Checker  
ISSUE DATE: 2-14-2022

# P101

**DOMESTIC WATER SUPPLY NOTES**

**SERVICE ENTRANCE**

- LOCATE WATER SERVICE ENTRANCE & SHUT OFF VALVE ADJACENT WATER HEATER
- WATER HEATER TO BE 50 GALLON TANK
- EXTEND WATER SERVICE TO SITE UTILITY OR PRIVATE WELL SYSTEM
- SUPPLY WATER HEATER WITH MIN 1" COLD WATER LINE

**DOMESTIC FIXTURES**

- RUN 3/4" HOT AND COLD WATER LINES FROM SERVICE ENTRY TO ALL SINKS AND SHOWERS

**WASHER BOX**

- RUN 3/4" COLD AND 1/2" HOT WATER LINES TO WASHER BOX. REF PLAN FOR LOCATION

**DISH WASHER**

- IF INSTALLED, RUN HOT WATER LINE TO DISHWASHER, SIZE ACCORDING TO MANUFACTURER REQUIREMENTS.

**HOSE BIBS**

- INSTALL 2 FREEZE PROOF HOSE BIBS, REF PLAN FOR LOCATION
- INSTALL BALL SHUT OFF VALVE AT FREEZE PROOF HOSE BIBS
- RUN 3/4" COLD WATER LINE TO EACH FREEZE PROOF HOSE BIB

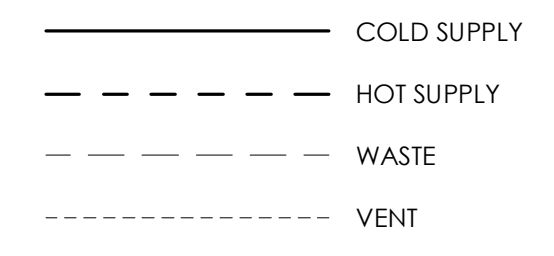

PLUMBING SYSTEM DESIGN IS DELEGATED TO THE WINNING CONTRACTOR. PROVIDED DESIGN IS FOR REFERENCE ONLY. SIZING AND LAYOUT OF PIPES ETC. BY SUBCONTRACTOR. FOLLOW NOTES AND INDUSTRY STANDARDS.

**WASTE AND VENT NOTES**

**SERVICE EXIT**

- EXTEND SANITARY SEWER TO SITE UTILITY OR PRIVATE DISPOSAL SYSTEM
- INSTALL FLOOR DRAIN AT WATER HEATER

**SANITARY SEWER NOTES**

- INSTALL MINIMUM 3" WASTE LINES AT WATER CLOSET
- INSTALL MINIMUM 2" WASTE LINES AT SHOWERS & BATH TUBS
- INSTALL MINIMUM 1 - 1/2" WASTE LINES AT LAVATORIES
- DISHWASHER WASTE TO TIE IN TO GARBAGE DISPOSAL
- WHERE POSSIBLE COMBINE WASTE LINES, ENLARGE COMBINED LINES AS NEEDED AND REQUIRED BY CODE

**VENT NOTES**

- INSTALL 1 - 1/2" VENT AT SHOWER DRAINS
- INSTALL 1 - 1/2" VENT AT WATER CLOSET DRAINS
- INSTALL 1 - 1/2" VENT AT LAVATORY DRAINS
- INSTALL 1 - 1/2" VENT AT KITCHEN SINK, DISHWASHER, AND GARBAGE DISPOSAL DRAINS
- WHERE POSSIBLE COMBINE VENTS BEFORE PENETRATING ROOF. ENLARGE COMBINED VENTS AS NEEDED AND REQUIRED BY CODE

**CLEANOUTS**

- INSTALL INTERIOR WALL CLEANOUTS AT KITCHEN SINK (UNDER CABINET) LAUNDRY ROOM (ADJACENT WASHER BOX) AND NEAR SERVICE EXIT.
- INSTALL EXTERIOR CLEANOUTS AT EACH LOCATION WHERE SANITARY SEWER EXITS THE BUILDING

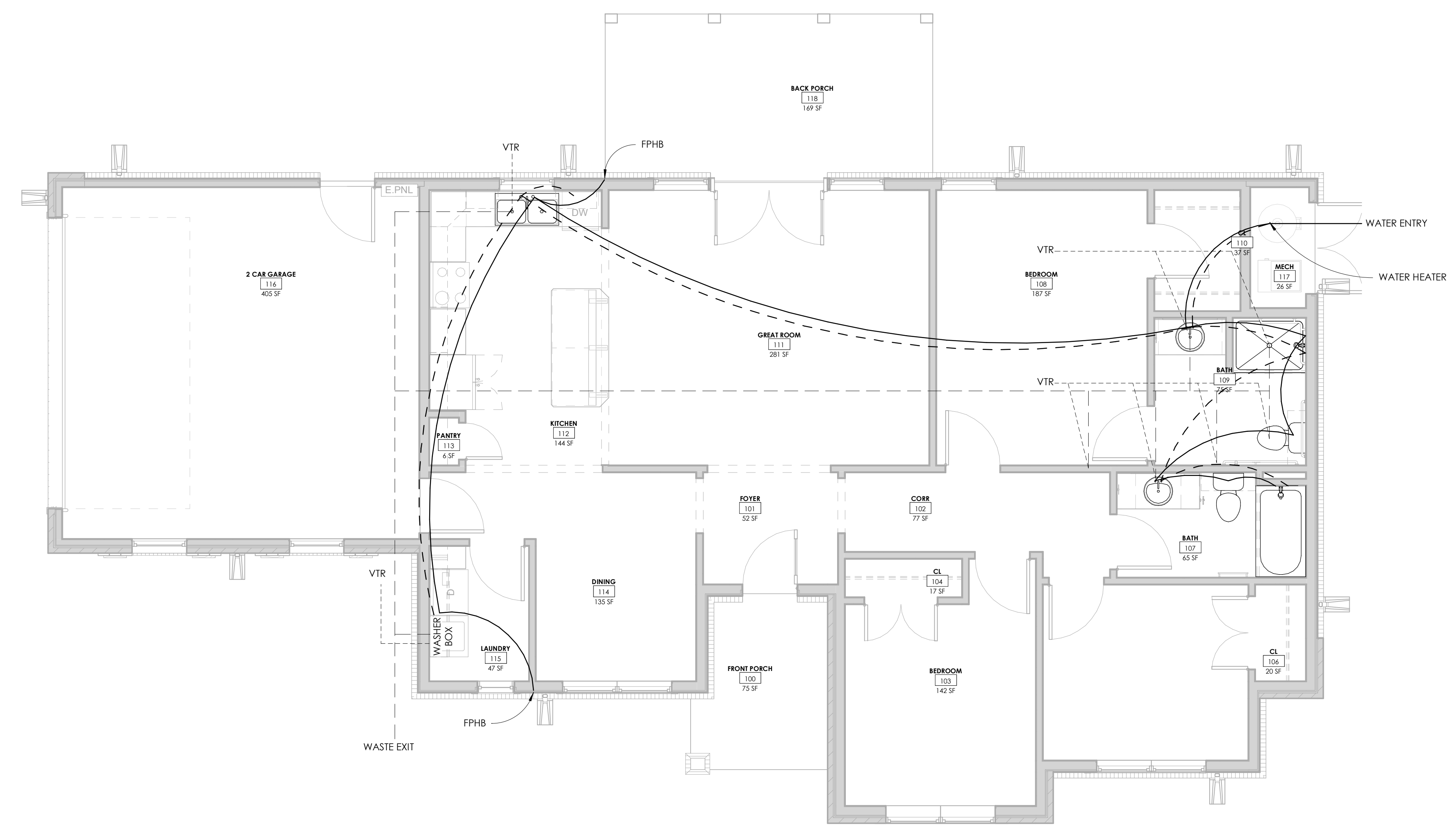

1 FLOOR PLAN - A (PLUMBING)  
1/4" = 1'-0"

This document, and the ideas and designs incorporated herein, are an instrument of professional service, in the property of TriArch, and is not to be used, in whole or in part, for any other project, without the written authorization of TriArch.

24-02022-12-24-20 PM

PRINT THIS SHEET FULL SIZE (11" X 17")